



## ZF continuously variable transmission ZF ECCOM in drop design

ZF now offers globally unique high tech transmission technology also for the professional tractor class, contributing one more time to improve your productivity and competitiveness with innovative drive solutions.

The continuously variable transmissions of this series have been developed for modern high-horse-power tractors between 400 and 650 HP and are specifically adapted to the requirements of vehicles with frame-built chassis. A modular design provides everything that could be desired, when it comes to flexible configuration of the power distribution to the drive system and to the optional PTOs.



- Continuously variable gear ratio
- Infinite number of „gears“
- Active standstill control
- Various driving strategies  
(e.g. automatic mode, PTO mode, cruise control)
- Modular design and many optional features
- Increased productivity
- Higher application flexibility (tractors, scrapers)

## ECCOM 5.5

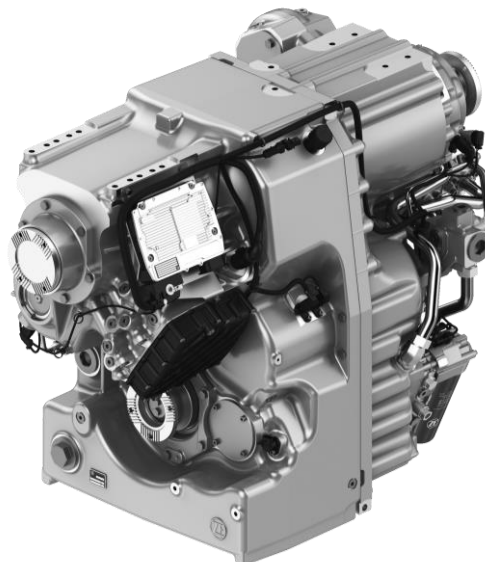

## ECCOM 5.5 back view and left side view

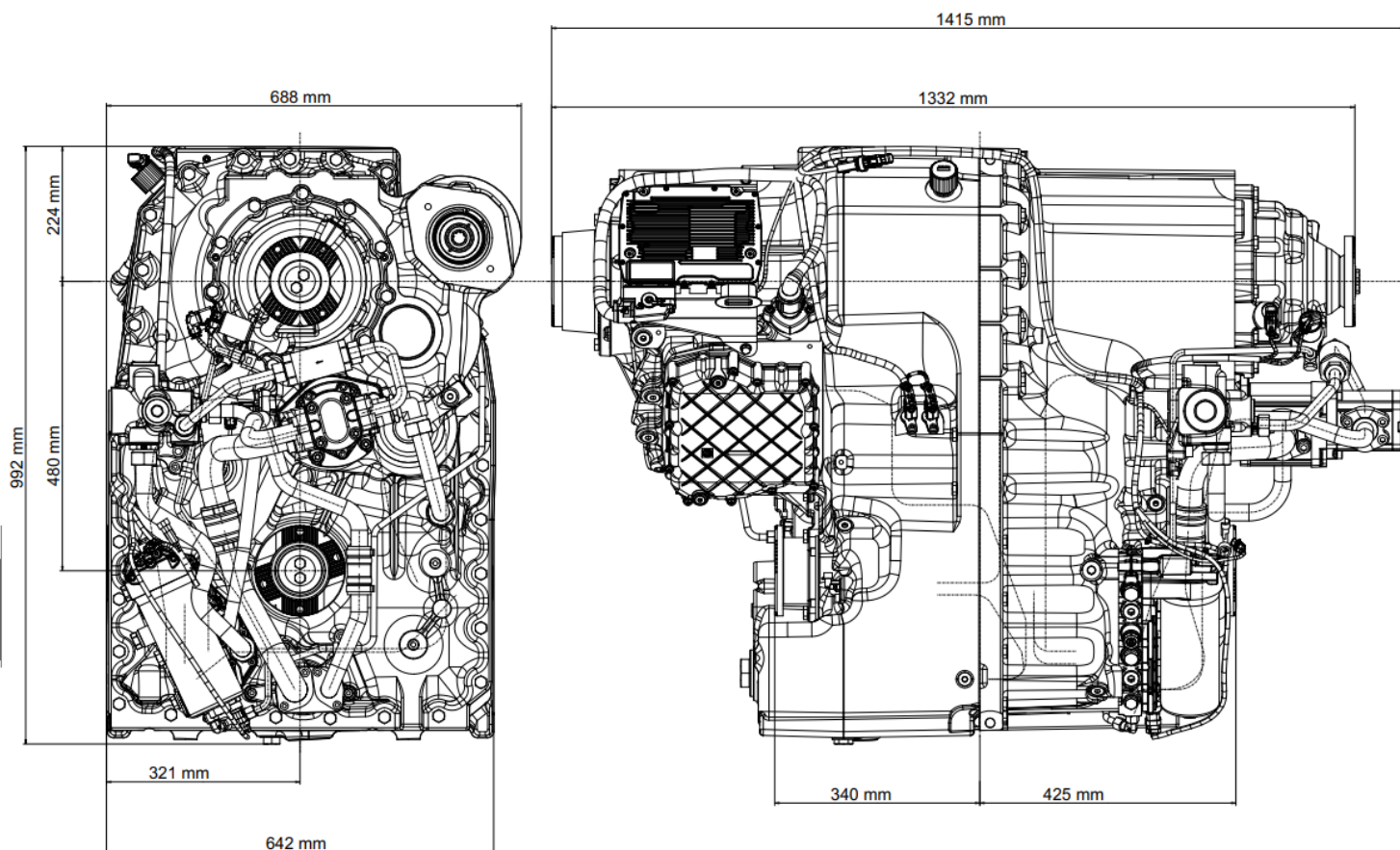

| Technical Data  | CVT ECCOM 5.5  |
|---|--|
| Max. Engine power (reference value [kW/HP] according to ISO 14396 | 480 / 650  |
| Max. transmission input power [kW/HP]                             | 443 / 602  |
| Input speed [1/min]   | 1,900 - 2,200  |
| Input torque max. [Nm]/lb-ft                                      | 2,680 / 1,976  |
| Speed max. F/R [km/h]   | 50 / 30  |
| Gross vehicle weight max. [kg]                                    | 40,000   |
| Rear tire size max.   | 1,025 / 95R50  |
| Four wheel drive  | Rigid through-drive; optional: multi-disk clutch, without four wheel drive |
| PTO   | Without PTO shaft; optional: multi-disk clutch with flange                 |
| Parking brake   | Dry disk brake   |