

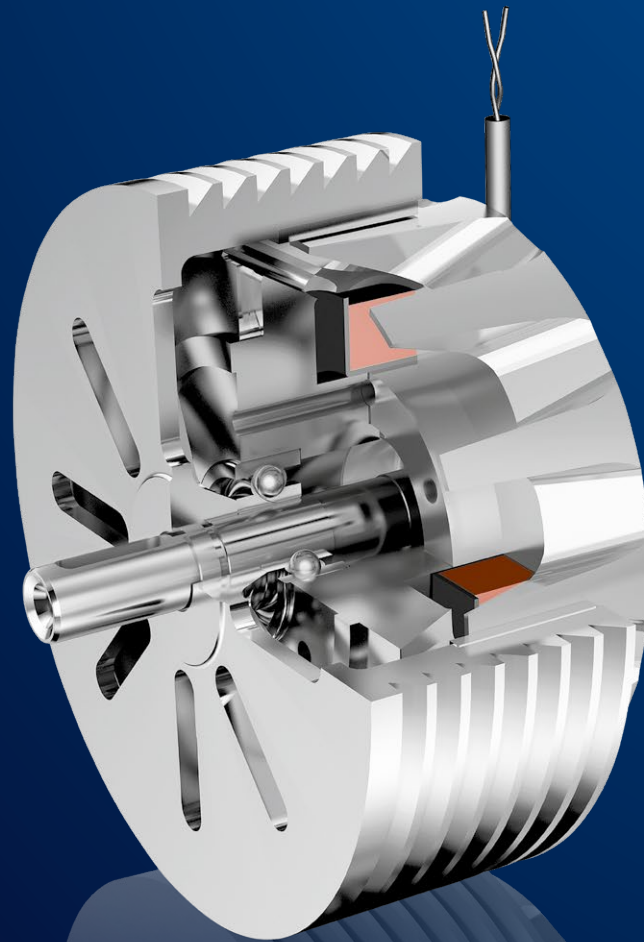

Products of Great Value

Hysteresis Brakes and Hysteresis Clutches
with Electronic Control Unit

Tiratron



Content

04	Hysteresis Products
06	Hysteresis Brakes
08	Torque Optimized Hysteresis Brakes
14	Power Optimized Hysteresis Brakes
16	Power Optimized Hysteresis Brakes with Gearbox
18	Permanent Magnet Hysteresis Brake
20	Hysteresis Clutches
24	Electronic Control Unit ERM
26	The ZF Group

The expert for the Industry !

Our enthusiasm for innovative products and processes and our uncompromising pursuit of quality have made us a global leader in driveline and chassis technology. We are contributing towards a sustainable future by producing advanced technology solutions with the goal of improving mobility, increasing the efficiency of our products and systems, and conserving resources. Our customers in the automotive and industrial sectors welcome our determined focus on products and services, which provide great customer value.

Hysteresis Products

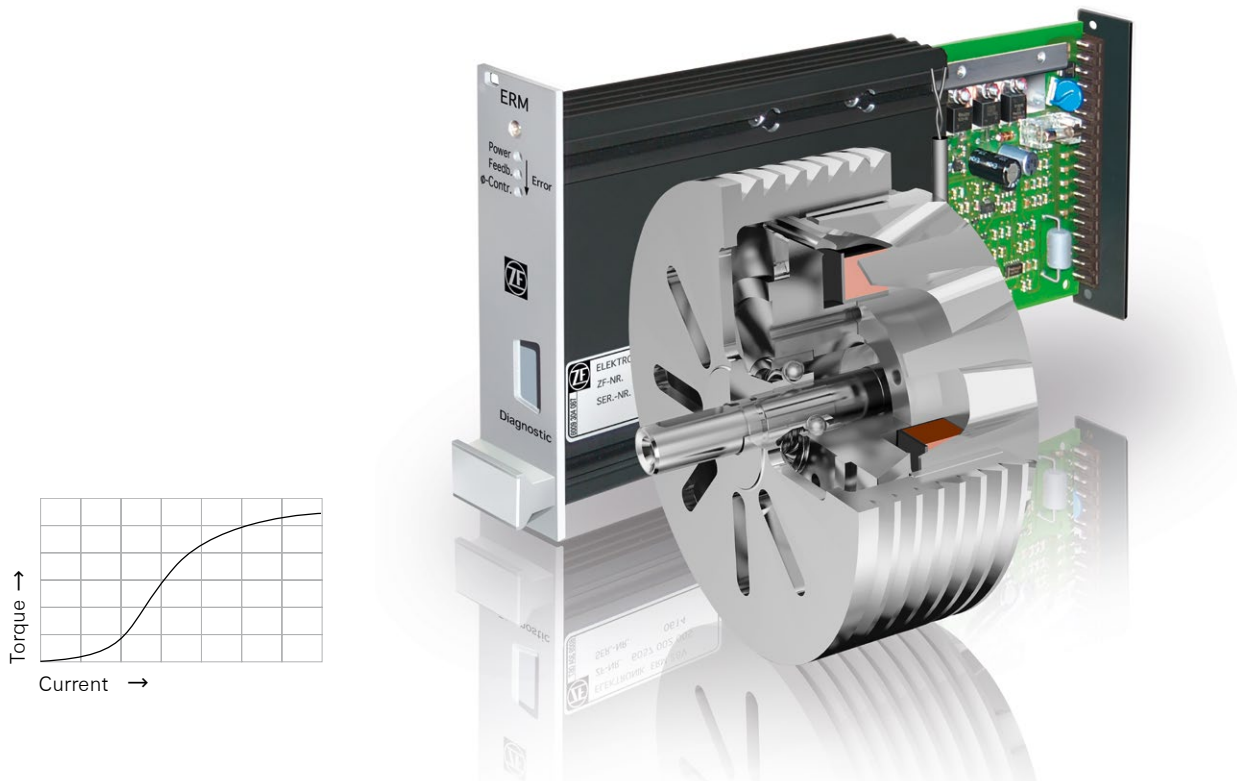

ZF's Hysteresis Components are Brakes, Clutches and ERM Electronic Control Unit.

Tiratron, i.e. the combination of the brake with the electronic control unit or the clutch with the electronic control unit enables the exact control of tensile forces as well as a defined setting of a torque.

Exemplary operation

The Hysteresis Technology can be used and applied wherever products such as paper, wire etc. are processed by winding. Loads can be simulated with ZF Tiratron on test benches or in ergometers.

Non-contact torque transmission

The non-contact torque transmission via the airgap of the mechanical components brake or clutches is continuously variable. Then constant and free of any wear. With normal operating conditions, no maintenance is required.

Continuously adjustable torque

The brake torque or the transferable torque depends only on the current. It is largely speed-independent and from zero to maximum speed constantly available.

High slip power in continuous mode, overload capability

The brakes of the power optimized series can bear high slip power continuously. Additionally, short-term overload is also possible in this model range.

The system, consisting of the break or clutch and the universal usable control unit, is standardized and can be used for most of the applications.

The operating principles of hysteresis brakes and clutches are based on the magnetic force effect of attracting poles in synchronous mode and on continuous magnetic reversal in slip mode.

Application as holding brake

Hysteresis brakes can also be used as holding brakes without (differential) speed. An initial twisting/displacement of the rotor relative to the brake solenoid of around 5-10° is required for this. This also applies to the reversal of the rotational direction.

Installation Examples

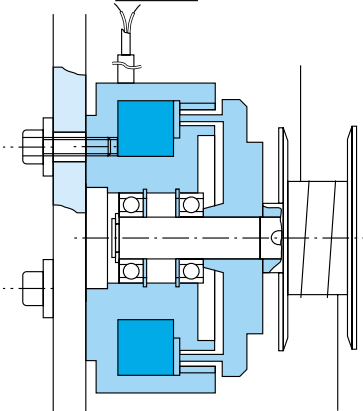

Hysteresis brakes to produce a defined thread tension.

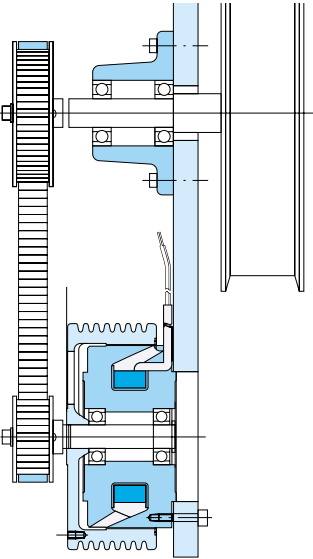

Hysteresis brake to unwind a tape with constant tensile force. A toothed belt is used to produce a higher braking torque.

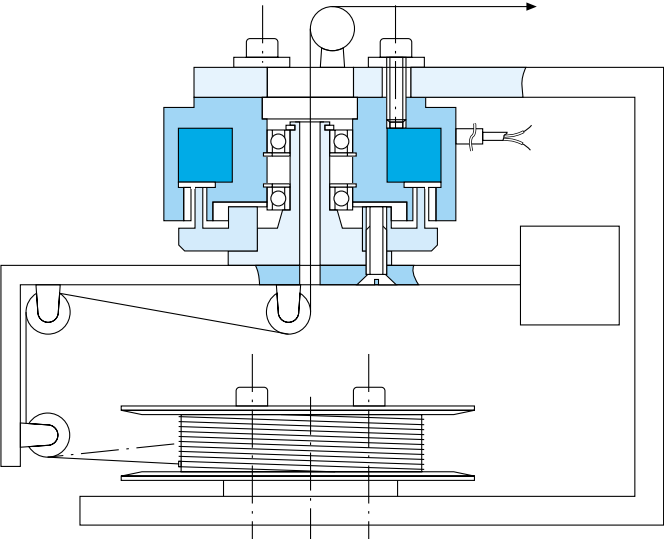

Hysteresis brakes with flyer for unwinding flexible leads with constant tensile force.

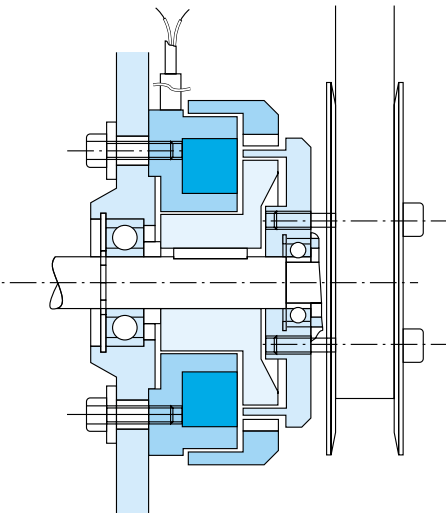

Hysteresis clutches to wind up a foil with constant tensile force.

Hysteresis Brakes

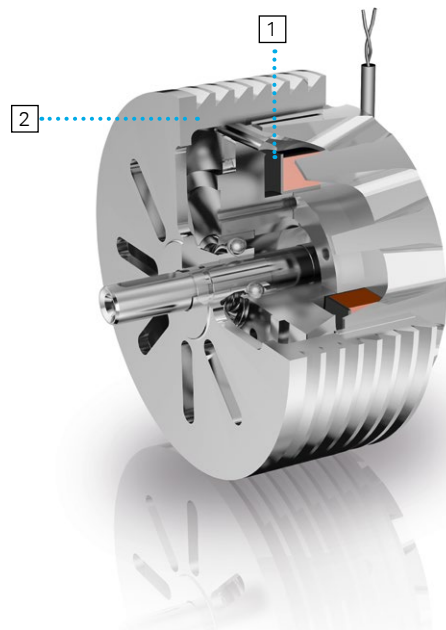

Bearing version with shaft

1. Brake magnet with solenoid
2. Armature with hysteresis ring

The armature and the brake magnet are the individual components making up the ZF Hysteresis Brake. Types: Torque-optimized series / Power-optimized series / Power-optimized series with gearbox

Hysteresis Brakes are offered with a nominal torque ranging from 0.05 Nm to 520 Nm, depending on the size, available as bearing version with shaft end or non-bearing version as individual components.

The brakes have a power capacity of up to 2 000 W during continuous operations and of 4 000 W during short-term operations (interval operations).

They can be used both in the slip mode range and as holding brake.

Slip power

During continuous slip mode, heat generation caused by slip power must also be taken into account. Permissible continuous slip power limits are included in the selection tables. Required continuous slip power is calculated as follows:

$$P_s = T_s \cdot \frac{n_s}{9.55} \quad \text{or} \quad P_s = F \cdot v$$

P_s : Slip power in W

T_s : Slip torque in Nm

n_s : Slip speed in rpm

F : Tensile force in N

v : Bandpullspeed in m/s

Residual magnetism

Torque ripple occurs as a result of residual magnetism when the current is changed to below 50% of the initial value either abruptly or without turning the armature/rotor. A reliable way to avoid torque ripple is to reduce the current while simultaneously turning the armature and rotor resp. brake solenoid during approx. 1 turn (relative). Every following operation cycle is removing possible residual magnetism.

Manufacturing and torque tolerances

When ordering the standard version according to the catalog, an individual unit's torque-current curve as well as its torque relative to nominal current may deviate slightly from the published data due to production tolerances. A typical deviation for individual units would be +/- 10 %.

Upon request, we can offer specially matched pairs for those applications requiring lower tolerances. The actual torque-current curve for a specific unit is exactly reproducible under the same conditions.

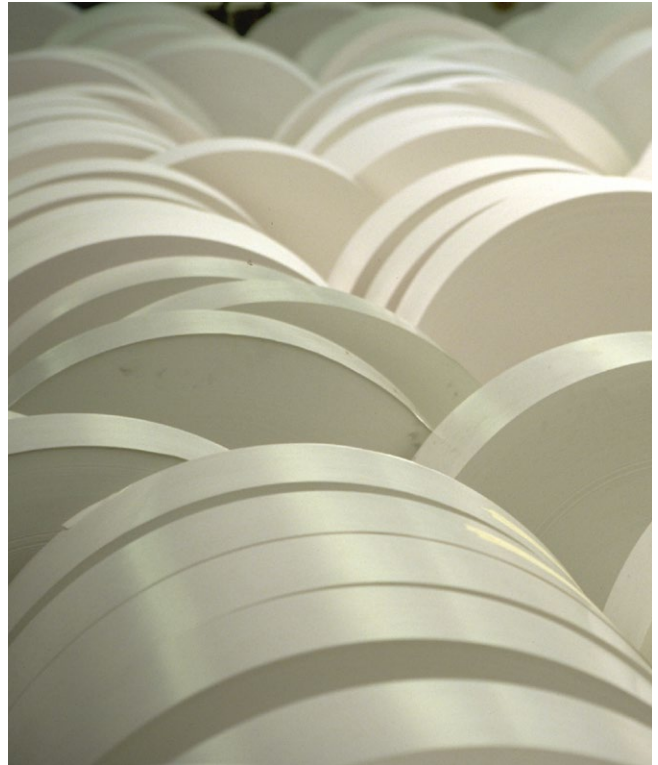

Application examples:
Weaving, Winding, Twisting, Labeling.

Torque Optimized Hysteresis Brakes

Technical Data		EBU 0.05 L	EBU 0.1 LA	EBU 0.1 LW
Nominal torque*	T_N [Nm]	0.08	0.15	0.15
Max. slip power	P_{max} [W]	15	32	32
Nominal current	I_N [A]	0.225	0.4	0.4
Nominal voltage	U_N [V]	23	30	30
Max. speed	n_{max} [rpm]	15 000	15 000	15 000
Armature side inertia torque	J_{arm} [kgcm ²]	0.14	0.1	0.1
Power consumption at coil temperature 70° C	P_{70} [W]	4.8	10	10
Mass	m [kg]	0.37	0.5	0.5

* Tolerances: See Scattering/Torque tolerances
Ambient temperature up to 40° C

Dimensions [mm]		EBU 0.05 L	EBU 0.1 LA	EBU 0.1 LW
A		53.5	51	49
C		-	35	-
D ₁		49	54	54
D ₂		45	-	-
D ₇		70	-	-
D ₈ h8		30	25	-
E		34.5	-	-
c		4	-	-
d _j 6		-	-	5
d ₂		24/2x180	32/3x120	-
d ₃		M4	M3	-
d ₄		62	40	40
d ₅		4.3	M4	M4
d ₁₁		29	-	-
e		3	5	6
f ₁		19 +/-0.5	-	-
f ₂		15	7.5	-
f ₃		5	-	-
f ₄		6	-	-
f ₅		4	-	-
l		-	-	30

Available versions

EBU 0.05 L

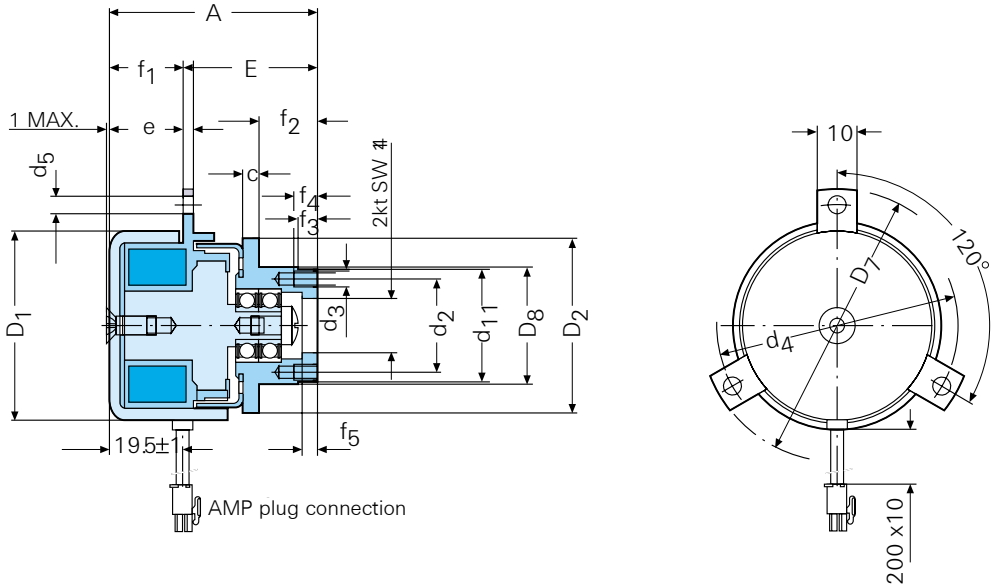

EBU 0.1 LA

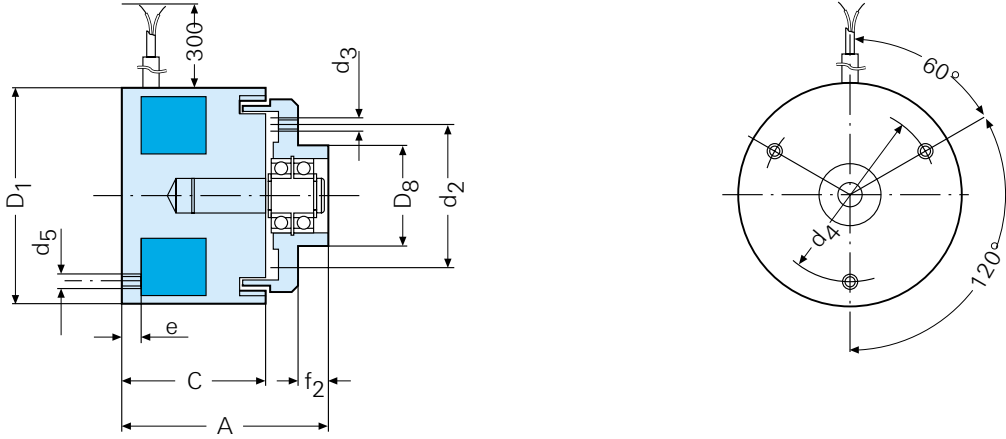

EBU 0.1 LW

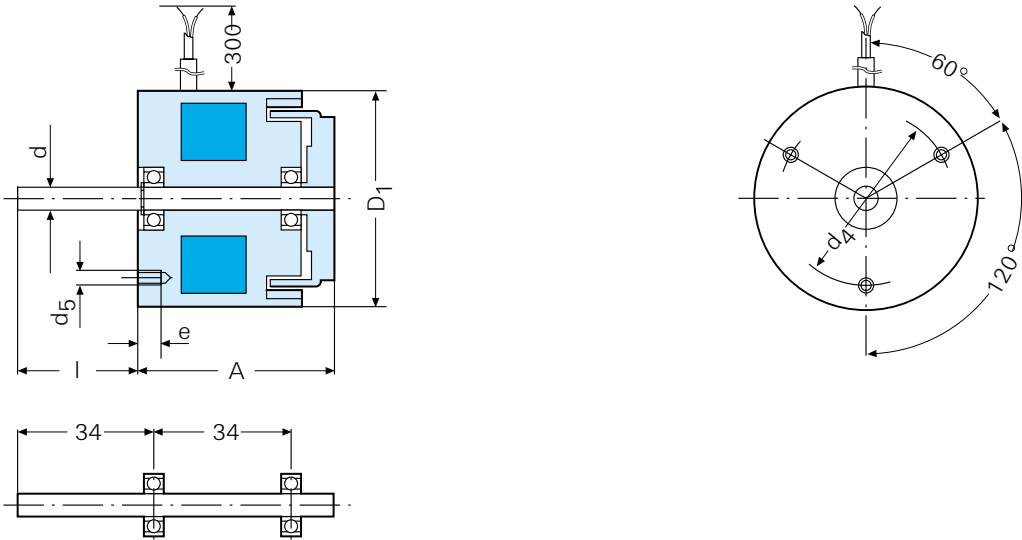

Torque Optimized Hysteresis Brakes

Technical Data		EBU 0.3 L	EBU 1 L	EBU 3 L	EBU 10 L	EBU 30 L
Nominal torque*	T_N [Nm]	0.4	1.1	3.3	12	39
Max. slip power	P_{max} [W]	63	125	250	500	1 000
Nominal current	I_N [A]	0.75	1.25	1.25	1.5	2.2
Nominal voltage	U_N [V]	30	30	30	30	30
Max. speed	n_{max} [rpm]	10 000	6 500	4 500	3 000	2 000
Armature side inertia torque	J_{arm} [kgcm ²]	1	3	13	81	404
Power consumption at coil temperature 70° C	P_{70} [W]	18	30	30	36	53
Mass	m [kg]	1.1	2.2	5.6	18	47

* Tolerances: See Scattering/Torque tolerances
Ambient temperature up to 40° C

Dimensions [mm]	EBU 0.3 L	EBU 1 L	EBU 3 L	EBU 10 L	EBU 30 L
A	58	56.5	76.5	102	136
D ₁	74	102	138	210	310
D ₂	62	91	120	180	266
D ₃	22 K7	35 H7	42 K6	80 H7	140 H7
D ₇	-	-	131 f7	160 h8	240 h8
D ₈	55	64	95	-	-
L _A DIN625	608	6 201	6 004	6 006	6 209
L _B DIN625	6 000	6 201	6 004	6 006	6 209
b	2	4	2	6	8
d	7 h7	9 h7	14 h7	24 h7	38 h7
d ₄	50	60	60	106	170
d ₅	M 5	M 5	M 6	M 8	M 8
d ₁₀	-	-	M5 x 125	M8 x 19	M12 x 24.5
e	7	7	14.5	20	30
f ₁	-	-	2.5	5	4
f ₂	3	5	5	-	-
l	16	20	30	50	80
l ₁	8	10	22	40	63
l ₂	34	43.7	57	82.5	132.5
l ₃	32.5	20.8	38	51	59
v _{xw}	-	-	5 x 3	8 x 4	10 x 5
w	1	1	-	-	-

Version

EBU 0.3 L -
30 L

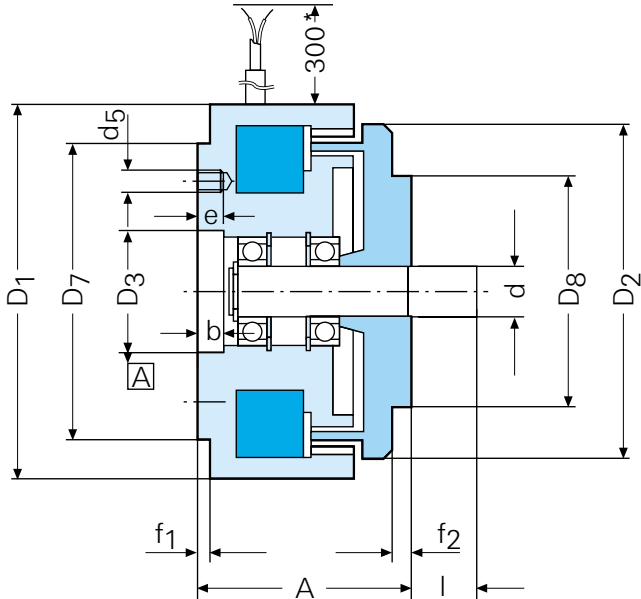

EBU 0.3 L
1 L

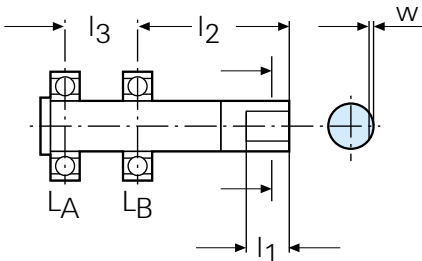

Sketch Shaft / Bearings

EBU 3 L
10 L
30 L

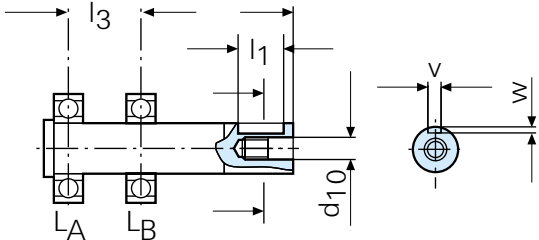

Torque Optimized Hysteresis Brakes

Technical Data		EBU 0.3	EBU 1	EBU 3	EBU 10	EBU 30
Nominal torque*	T_N [Nm]	0.4	1.1	3.3	12	39
Max. slip power	P_{max} [W]	63	125	250	500	1 000
Nominal current	I_N [A]	0.75	1.25	1.25	1.5	2.2
Nominal voltage	U_N [V]	30	30	30	30	30
Max. speed	n_{max} [rpm]	10 000	6 500	4 500	3 000	2 000
Armature side inertia torque	J_{arm} [kgcm ²]	0.7	2	9.1	59	340
Power consumption at coil temperature 70° C	P_{70} [W]	18	30	30	36	53
Mass	m [kg]	1.0	1.8	5.0	16	42

* Tolerances: See Scattering/Torque tolerances
Ambient temperature up to 40° C

Dimensions [mm]	EBU 0.3	EBU 1	EBU 3	EBU 10	EBU 30
A	55	51.5	71.5	102	136
D ₁	74	102	138	210	310
D ₂	62	91	120	180	266
D ₃	22 K7	35 H7	42 K6	80 H7	140 H7
D ₄	19	32 K6	42 K6	80	140
D ₅	32 K7	42 K7	52 K7	90 H7	110 H7
D ₆	26 K7	-	-	202	300
D ₇	-	-	131 f7	160 h8	240 h8
a	19	17	16.5	26	43
b	11	4	-	47	57
c	10	15	16.5	10	14
d ₂	42	50	80	105 +/- 0.1	130 +/- 0.1
d ₃	M 4	M 5	M 5	M 8	M 8
d ₄	50	60	60	106 +/- 0.2	170 +/- 0.2
d ₅	M 5	M 5	M 6	M 8	M 8
d ₆	-	-	-	186 +/-0.2	275 +/-0.2
d ₇	-	-	-	M8	M10
e	7	7	11	20	20
f	5.2 +0.1	10.7 +0.1	12.0 +0.1	-	-
g	-	18.2	19.2	12	11
h	25	8.4	22.8	-	-
f ₁	-	-	2.5	5	4

Available versions

EBU 0.3

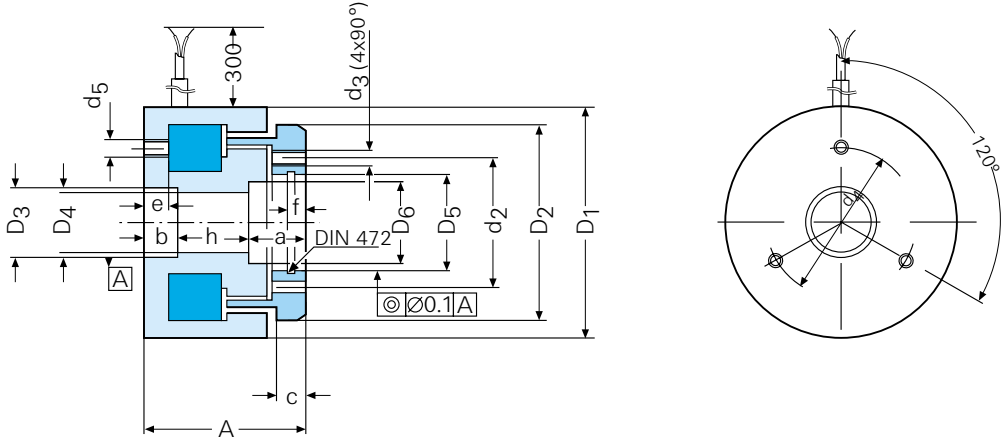

EBU 1
EBU 3

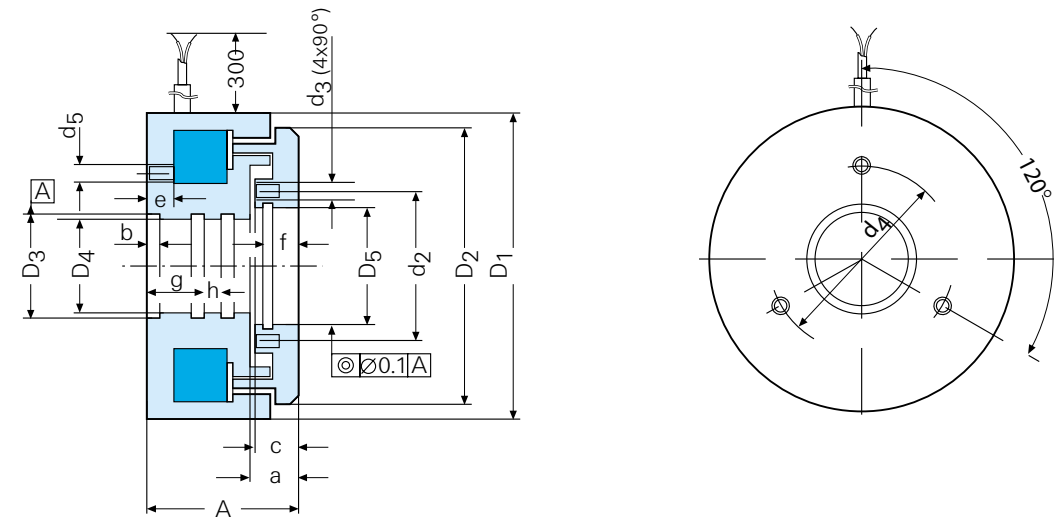

EBU 10
EBU 30

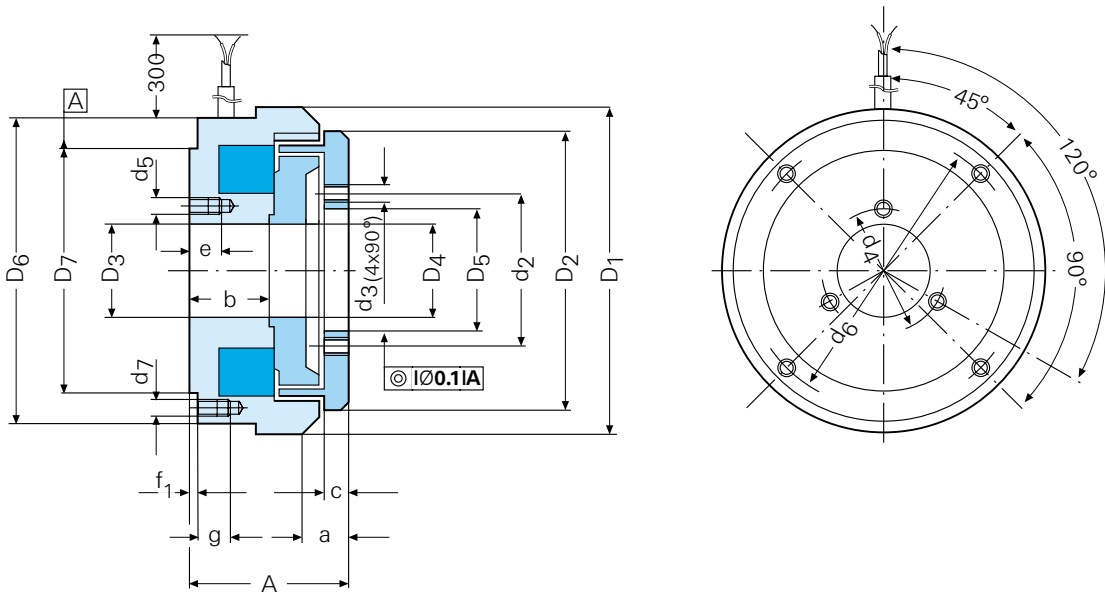

Power Optimized Hysteresis Brakes

Technical Data		EBU 250/1	EBU 500/3	EBU 1000/10	EBU 2000/30
Nominal torque*	T_N [Nm]	0.6	2.5	9	26
Nominal torque at speed n	T_P [Nm]	0.75	3.0	12.5	38
Permitted speed in continuous mode at nominal torque T_P	n [rpm]	3 200	1 500	750	500
Max. slip power in continuous mode	P [W]	250	500	1 000	2 000
Max. slip power in short time mode	P_{max} [W]	500	1 000	2 000	4 000
Nominal current	I_N [A]	1.1	1.4	1.9	2.7
Nominal voltage	U_N [V]	24	24	24	24
Max. speed	n_{max} [rpm]	10 000	6 500	4 500	3 000
Shaft side inertia torque	J_W [kgcm ²]	4.8	33.5	244.5	1 157
Power consumption at coil temperature 70° C	P_{70} [W]	19	24	33	47
Mass	m [kg]	1.4	3.7	11	31

* Tolerances: See Scattering/Torque tolerances
Ambient temperature up to 40° C

Dimensions [mm]		EBU 250/1	EBU 500/3	EBU 1000/10	EBU 2000/30
All bearing types balanced, balanced quality 6.3	A_1	55	68	92	122
	B_1	24.5	32	40	53.5
	B_2	25	32.5	41	54
Non-bearing types when supported in d5: balance quality 23.6	B_3	12.5	14.5	20.5	28
	D_1h7	50	80	110	180
	D_2	75	112	168	233
	D_3	93	140	210	292
	E	10.5	13	20	25
	$d_1 k6$	11	14	19	24
	d_2	M 4	M 5	M 6	M 8
	d_3	M 5	M 6	M 8	M 12
	d_4	60	100	130	215
	d_5S7	12	15	20	25
	d_6H7	28	35	52	80
	a	3	4	4	6
	b	2	2.5	3.5	4
	c	7	8	12	16
	e	11	13	15	20
l_1	23	30	40	50	
l_2	18	22	28	36	
l_3	31	40.5	54	69.5	
l_4	32.5	41	52	71	
l_5	39.5	51	68.5	89	
v P9	4	5	6	8	
w+0.2	2.5	3	3.5	4	
L_A DIN625	6 001	6 202	6 304	6 405	

Available versions

A: Bearing type. shaft right side

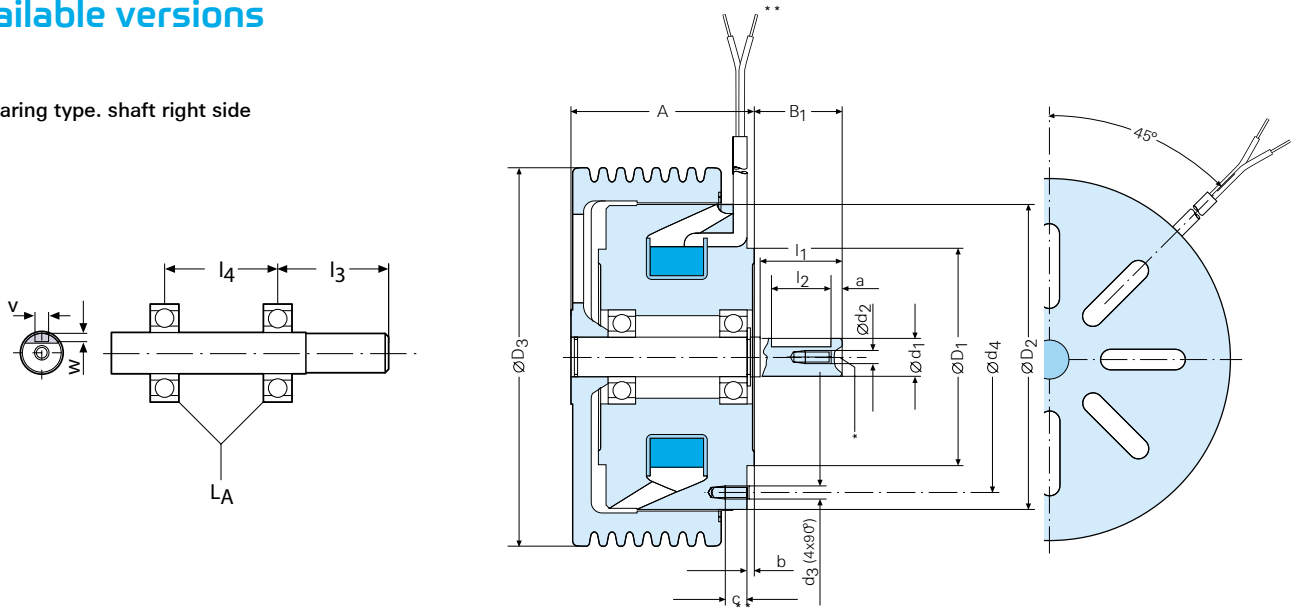

B: Bearing type. shaft left side

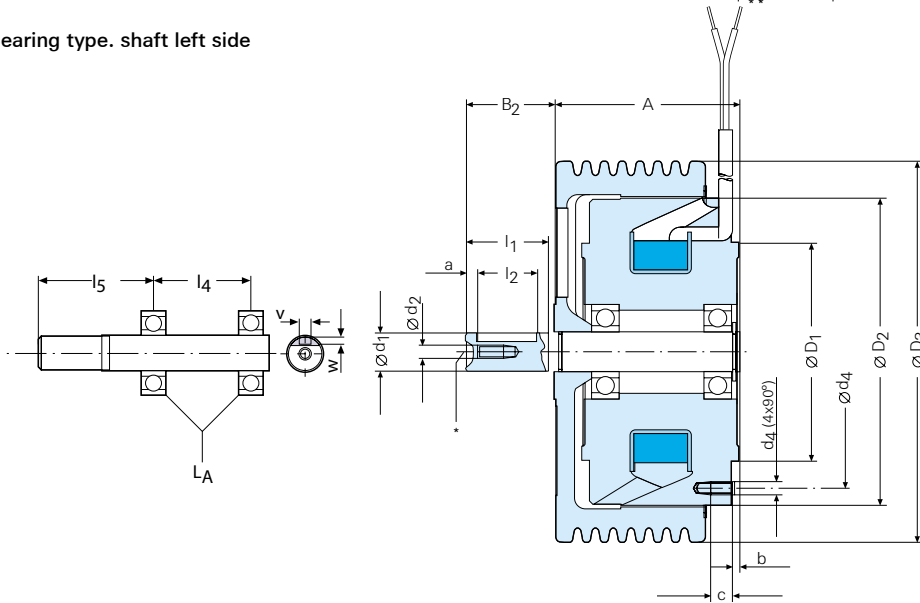

C: Non-bearing type. for integrated solutions

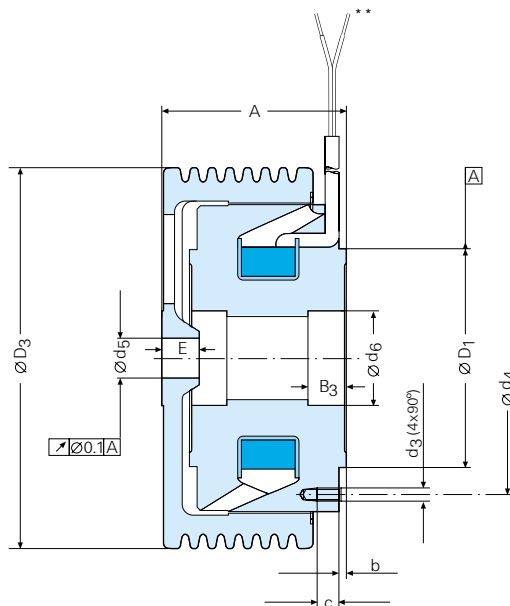

* Centering DIN 332 (D)

** Connection leads 0.5 mm², length 500 mm

Power Optimized Hysteresis Brakes with Gearbox

Technical Data		EBU 500/30 G	EBU 500/60 G	EBU 1000/100 G	EBU 2000/300 G	EBU 2000/600 G
Ratio	i^{**}	10	20	10	10	20
Nominal torque* standstill	T_N [Nm]	25	50	90	260	520
Nominal torque at speed n	T_P [Nm]	30	60	125	380	760
Permitted speed in continuous mode at nominal torque T_P	n [rpm]	150	75	75	50	25
Max. slip power in continuous mode	P [W]	500	500	1 000	2 000	2 000
Max. slip power in short time mode	P_{max} [W]	1 000	1 000	2 000	4 000	4 000
Nominal current	I_N [A]	1.4	1.4	1.9	2.7	2.7
Nominal voltage	U_N [V]	24	24	24	24	24
Max. speed	n_{max} [rpm]	600	300	400	300	100
Shaft side inertia torque	J_W [kgcm ²]	3 500	13 000	24 500	116 000	470 000
Power consumption at coil temperature 70° C	P_{70} [W]	24	24	33	47	47
Mass	m [kg]	6.5	7.9	17.5	46	68

* Tolerances: See Scattering/Torque tolerances

Ambient temperature up to 40° C

** Other ratios on request

Dimensions [mm]	EBU 500/30G	EBU 500/60 G	EBU 1000/100 G	EBU 2000/300 G	EBU 2000/600 G
A	220.7	248	302.3	387.7	477
B	155.7	183	213.8	269.6	359
D_3	140	140	210	292	292
$D_{11} g6$	70	70	90	130	160
$d_1 k6$	22	22	32	40	55
e_1	85	85	120	165	215
$\square f_1$	90	90	101	141	182
s_1	6.6	6.6	9	11	13
a	-	4	4	5	5
b	8	8	10	12.5	22
c_2	18	18	28	27	27
l_1	36	36	58	82	82
l_2	38	38	60	85	85
l_6	-	28	50	70	70
vP9	-	6	10	12	16
w +0.2	-	13.5	19	23	31.5
c_1	65	39	67	92	109

ZF Type:	EBU 500/30 G	EBU 500/60 G	EBU 1000/100 G	EBU 2000/300 G	EBU 2000/600 G
Brake EBU	500/3	500/3	1000/10	2000/30	2000/30
Gear PG	100/1	100/2	200/1	500/1	1200/2

The mounted planetary gearboxes have a drag torque depending on gear ratio and speed as well as operating and environmental conditions.

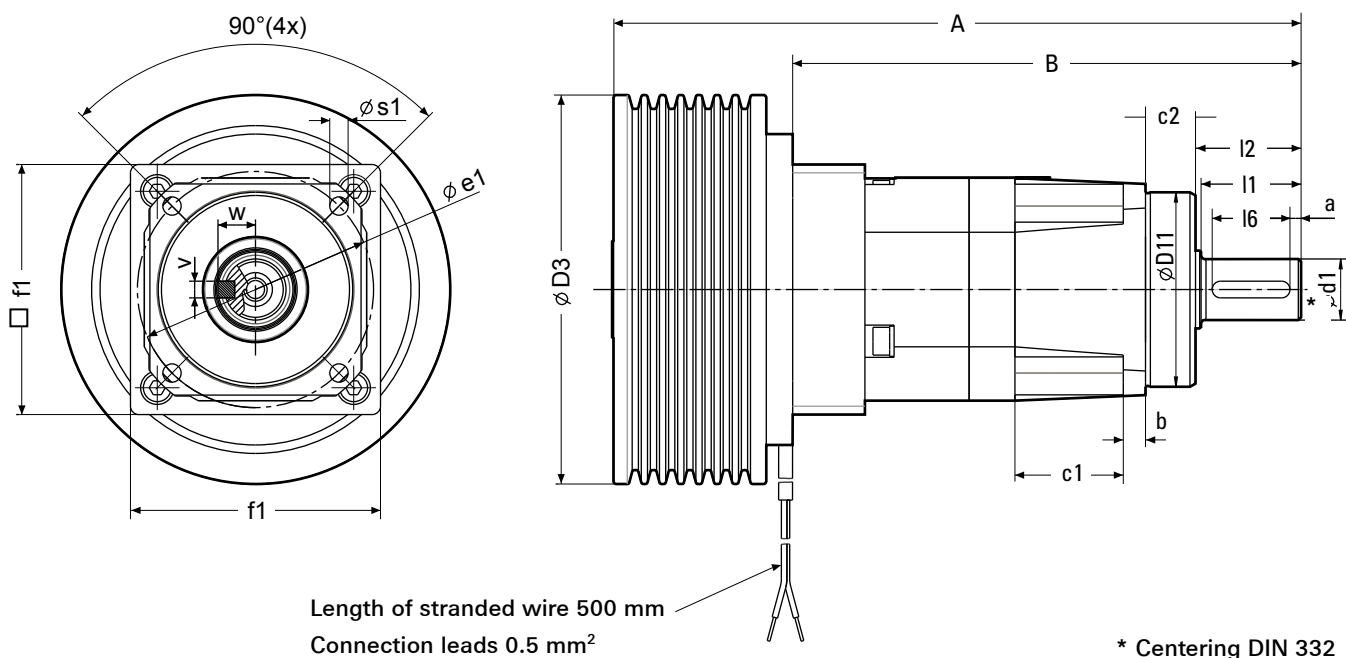

Additionally, technical information and notes on operation and maintenance please have a look at ZF Servoplan catalogue, as well as the operating instructions.

www.zf.com/industrial-drives/servoplan

Permanent Magnet Hysteresis Brake

Remarkable features of the permanent magnet (PM) hysteresis brake are its high nominal torque with a compact design. The brakes permanent magnet excitation makes it independent of any power supply. The torque values can be set and reproduced easily and in a user-friendly fashion with the 37-times detented setting ring. The tolerance of the nominal torque amounts to +/- 5 %.

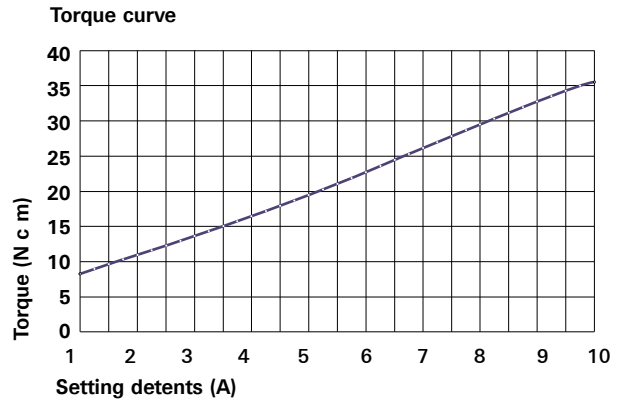

Technical Data		DBU 0.2 L
Max. nominal torque*	T_{Nmax} [Nm]	0.35
Min. nominal torque*	T_{Nmin} [Nm]	0.08
Number of detents	A	37
Permitted slip power in continuous mode	P [W]	20
Max. speed	n_{max} [rpm]	10 000
Intertia torque	J_w [kgcm ²]	0.63
Mass	m [kg]	0.36
Bearing type	LA DIN625	6 000

* Tolerances: See Scattering/Torque tolerances
Ambient temperature up to 40° C

Version

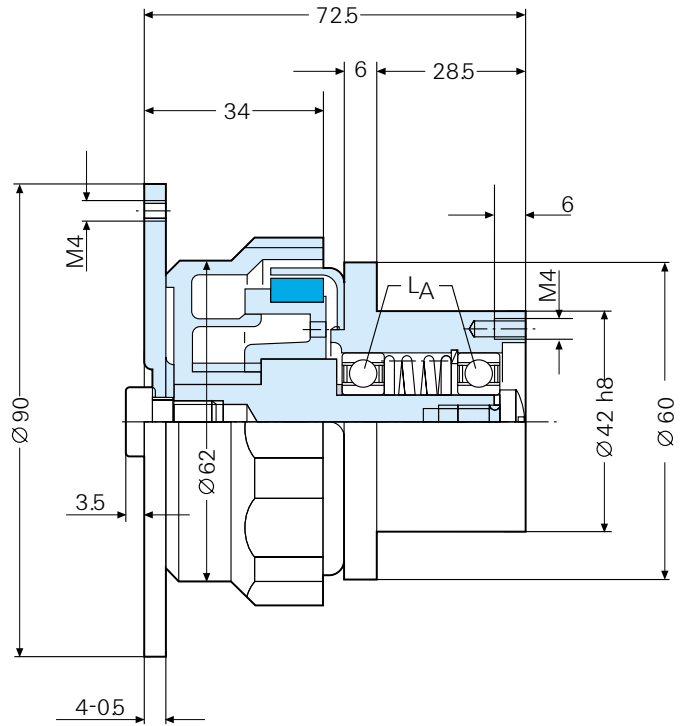
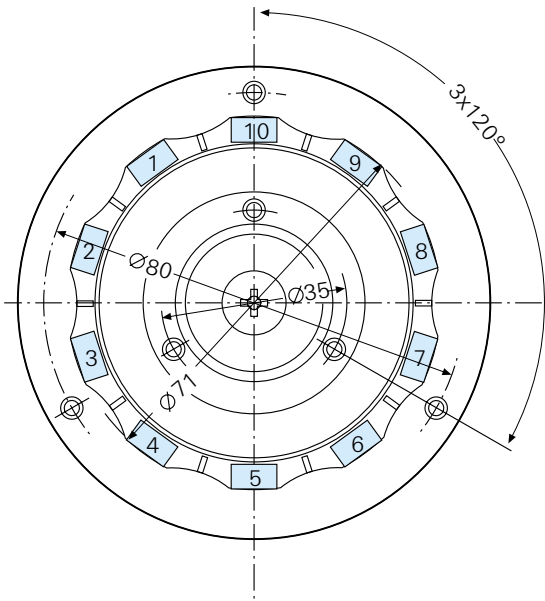

Torque-adjustment

All dimensions in mm

- 37 detents
- 10 marked numbers
- 10 intermediate numbers

Hysteresis Clutches

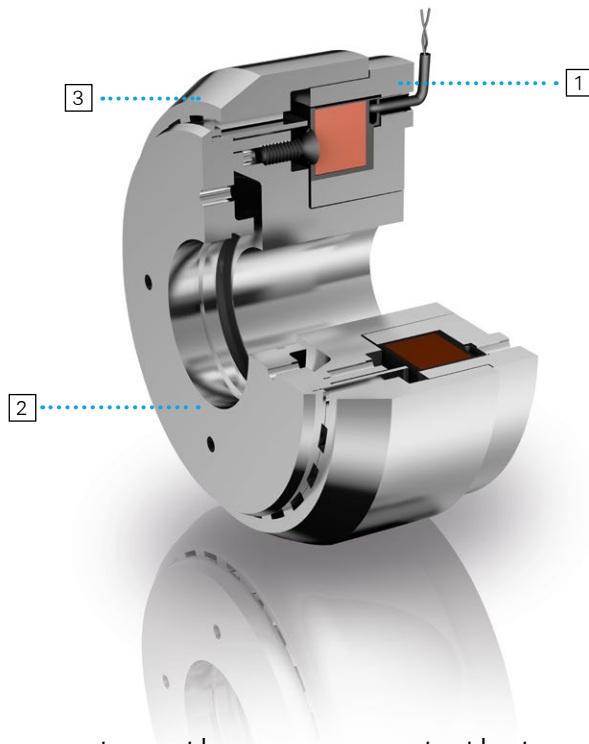

1. Clutch magnet with solenoid
2. Armature with hysteresis ring, usually output
3. Rotor, usually input

Rotor, armature and clutch magnet are the components that make up the ZF Hysteresis Clutch. The nominal torque covers a range from 0.4 Nm to 12 Nm.

The maximum continuous slip power of the hysteresis clutch amounts to 500 W. The ZF Hysteresis Clutch distinguishes itself by a stepless transition from synchronous to slip operations.

The magnitude of scattering and torque tolerances correspond to the values of the ZF Hysteresis Brakes. As is the case with the brakes, special series are available on demand.

Slip power

During continuous slip mode, heat generation caused by slip power must also be taken into account. Permissible continuous slip power limits are included in the selection tables.

Required continuous slip power is calculated as follows:

$$P_s = T_s \cdot \frac{n_s}{9.55} \quad \text{or} \quad P_s = F \cdot v$$

Residual magnetism

Torque ripple occurs as a result of residual magnetism when the current is changed to below 50% of the initial value either abruptly or without turning the armature/rotor. A reliable way to avoid torque ripple is to reduce the current while simultaneously turning the armature and rotor resp. brake solenoid during approx. 1 turn (relative). Each following operating cycle eliminates any possible remanence.

- P_s : Slip power in W
- T_s : Slip torque in Nm
- n_s : Slip speed in rpm
- F: Tensile force in N
- v: Band pull speed in m/s



Application example:

Tiratron Hysteresis brake EBU 3L
Labeling machine for PET filling line

Hysteresis Clutches

Technical Data		EKU 0.3	EKU 1	EKU 3	EKU 10
Nominal torque*	T_N [Nm]	0.4	1	3	12
Max. slip power	P_{max} [W]	63	125	250	500
Nominal current	I_N [A]	0.9	1.3	1.5	1.8
Nominal voltage	U_N [V]	30	30	30	30
Max. speed	n_{max} [rpm]	10 000	6 500	4 500	3 000
Rotor side inertia torque	J_{Rotor} [kgcm ²]	5.7	16.2	79.0	830.0
Armature side inertia torque	J_{arm} [kgcm ²]	0.7	2.0	9.1	59.0
Power consumption at coil temperature 70° C	P_{70} [W]	22	31	36	43
Mass	m [kg]	1.5	2.4	5.9	19.2

* Tolerances: See Scattering/Torque tolerances
Ambient temperature up to 40° C

Dimensions [mm]	EKU 0.3	EKU 1	EKU 3	EKU 10
A	60	59	79	118
D ₁	82	110	148	225
D ₂	62	91	119	180
D ₃ H8	50	80	100	150
D ₄ h8	80	107	140	205
D ₅	32 K7	42 K7	52 K7	90 H7
d ₂ +/-0.1	42	50	80	105
d ₃	M 4	M 5	M 5	M 8
d ₄ +/-0.1	62	92	116	174
d ₅	M 4	M 5	M 6	M 8
a	17	18	25	32
b +1/-0.5	3	3	4	6
c	10	15	16.5	10
e	5	7	12	20
f +0.1	5.2	10.7	12.0	-
g	40	38	50	80
z	3	3	3	4
d ₁ H7	15	30	40	50
v x w	5 x 1.3	8 x 1.7	12 x 2.1	14 x 2.6
d ₁ H7	12	25	30	40
v x w	4 x 1.1	8 x 1.7	8 x 1.7	12 x 2.1
d ₁ H7	12	20	20	30
v x w	-	6 x 1.7	6 x 1.7	8 x 1.7

Version

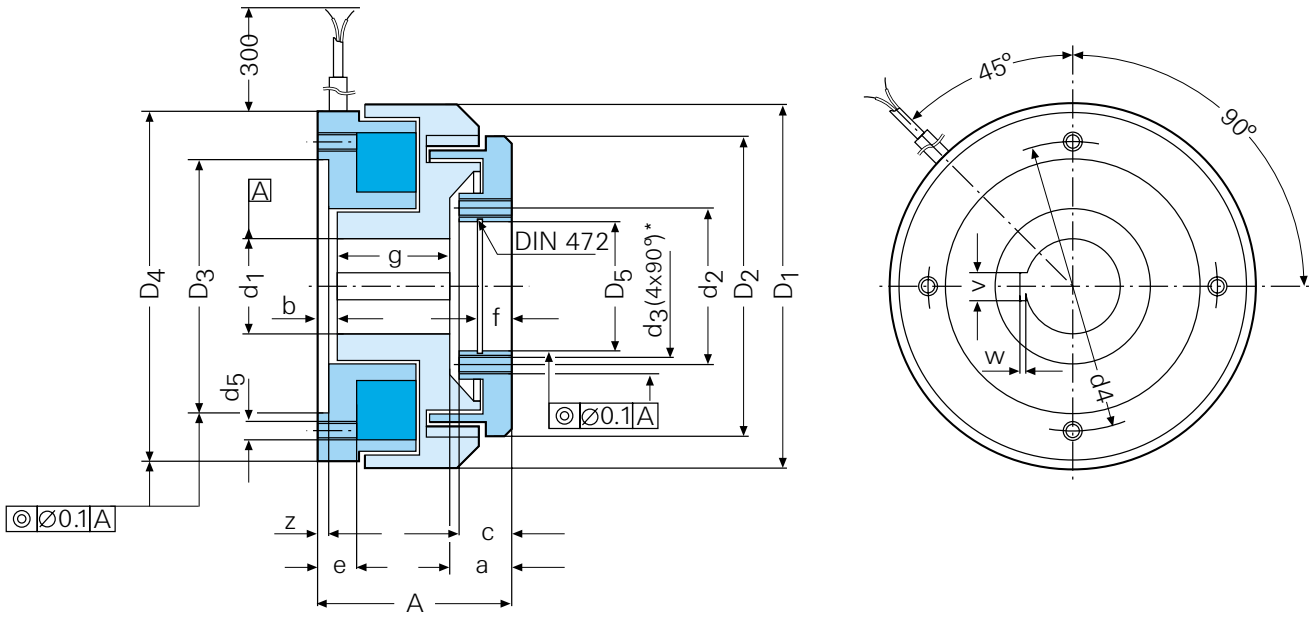

* EKU 0.3: d3 (3 x 120°)

Electronic Control Unit ERM



The ZF Hysteresis Electronic Control Unit makes it possible to set individual operating modes for the most diverse applications. The programming variations allow the Electronic Control Unit to be used for all brake and clutch types.

ZF Hysteresis Clutches and Brakes can be controlled in open or closed loop with the ZF Electronic Control Unit (ERM), depending on their application in different operating modes. The electronic components are micro-processor controlled and have programming, operating and diagnosis interfaces. The ERM has been set so as to feed the ZF Hysteresis Clutches and the ZF Hysteresis Brakes in an optimal way.

ERM operating modes

Open loop control:

- Current
- Torque
- \emptyset -sensing
- \emptyset -calculation

Closed loop control:

- PD position control
- PI force control
- PID mixed control
- Freely programmable (with diagnosis device MobiDig 200)

The ERM also offers the following special functions, depending on the operating mode:

- Maximum current: Output of the nominal current, depending on the size
- Zero current: The power output is set to zero
- Web-break detector in the operating mode \emptyset -calculation
- Compensation of the friction existing in the system

Open-loop controlled operating modes with a size codification are less suitable for the power-optimized brake series.

Please refer to the ERM operating manual for further information on the functions, connections etc.

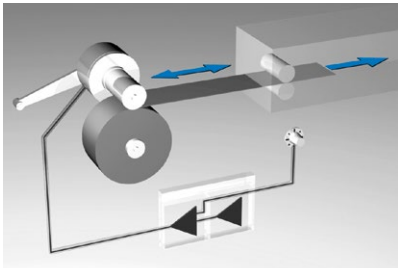

Open-loop control (current)

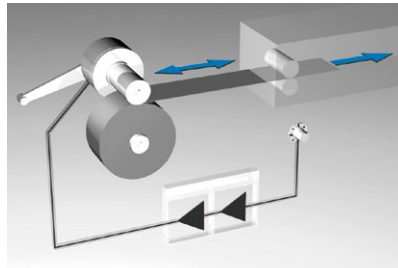

Open-loop control (torque)

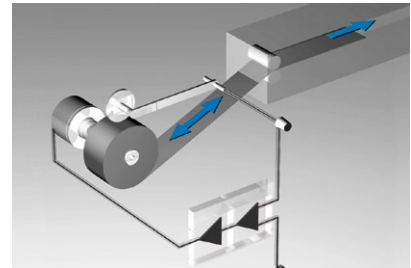

Open-loop controlled with θ -sensing

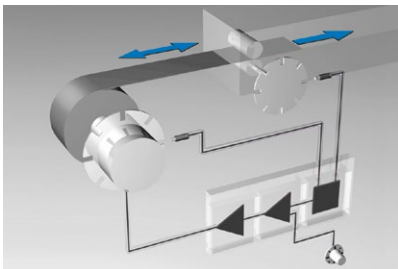

Open-loop controlled with θ -calculation

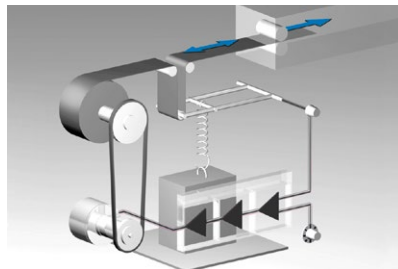

Closed-loop controlled with dancer force control

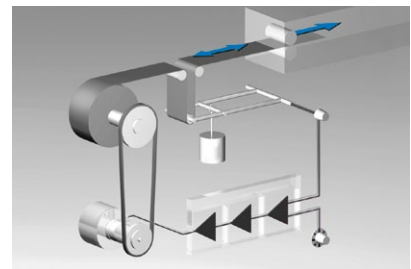

Closed-loop controlled with storage/
position control

Technical change without notice. For studies, please request installation drawings; only the data contained therein is binding.



Operating instructions and other product catalogs can be found here.

www.zf.com/industrial-drives/tiratron



Excellently networked worldwide

ZF offers you a comprehensive and attractive range of products and services to ensure mobility anywhere, at any time. Proximity to the customer is an essential element of the corporate performance.

The quality of innovative transmission systems is also a question of experience. For many decades, ZF transmissions have been a major impetus for on and off-road driving and technological progress.

ZF provides comprehensive system solutions all from a single source. The transmission components are perfectly harmonized with one another. The range of available power/ performance is, in each case, tailored to the specific demands of the market and manufacturers.

The result: Every ZF transmission system is a brand name product known for its reliability around the world.

Around the world, around the clock: ZF's service specialists are available anywhere and at any time.

The ZF Group

Shaping the future responsibly

Our enthusiasm for innovative products and processes and our uncompromising pursuit of quality have made us a global leader in driveline and chassis technology. We are contributing towards a sustainable future by producing advanced technology solutions with the goal of improving mobility, increasing the efficiency of our products and systems, and conserving resources.

Our customers in the automotive and industrial sectors welcome our determined focus on products and services, which provide great customer value. Improvements in energy efficiency, cost-effectiveness, dynamics, safety, and comfort are key to our work. Simultaneously, we are aiming for continuous improvement in our business processes and the services we provide. As a globally active company, we react quickly and flexibly to changing regional market demands with the goal of always providing a competitive price/performance ratio.

Our independence and financial security form the basis of our long-term business success. Our profitability allows us to make the necessary investments in new products, technologies, and markets thus securing the future of our company on behalf of our customers, market affiliates, employees, and the owners of ZF.

Our tradition and values strengthen our managerial decisions. Together, they are both an obligation and an incentive to maintain a reliable and respectful relationship with customers, market affiliates, and employees. Our worldwide compliance organization ensures that locally applicable laws and regulations are adhered to. We accept our responsibility towards society and will protect the environment at all of our locations.

Our employees worldwide recognize us as a fair employer, focusing on the future and offering attractive career prospects. We value the varied cultural backgrounds of our employees, their competencies, and their diligence and motivation. Their goal-oriented dedication to ZF, beyond the borders of their own field of work and location, shapes our company culture and is the key to our success.

ZF Group

Industrial Technology
Marine & Special Driveline Technology
88038 Friedrichshafen
Germany

Phone +49 7541 77-3610
Fax +49 7541 77-903610
industrial-drives@zf.com

Get to know more about the ZF products
for industrial automation



www.zf.com/industrial-drives