

Handling the Big Horses

8 TX 3000 – 8-speed automatic
powershift transmission for up to 3000 hp

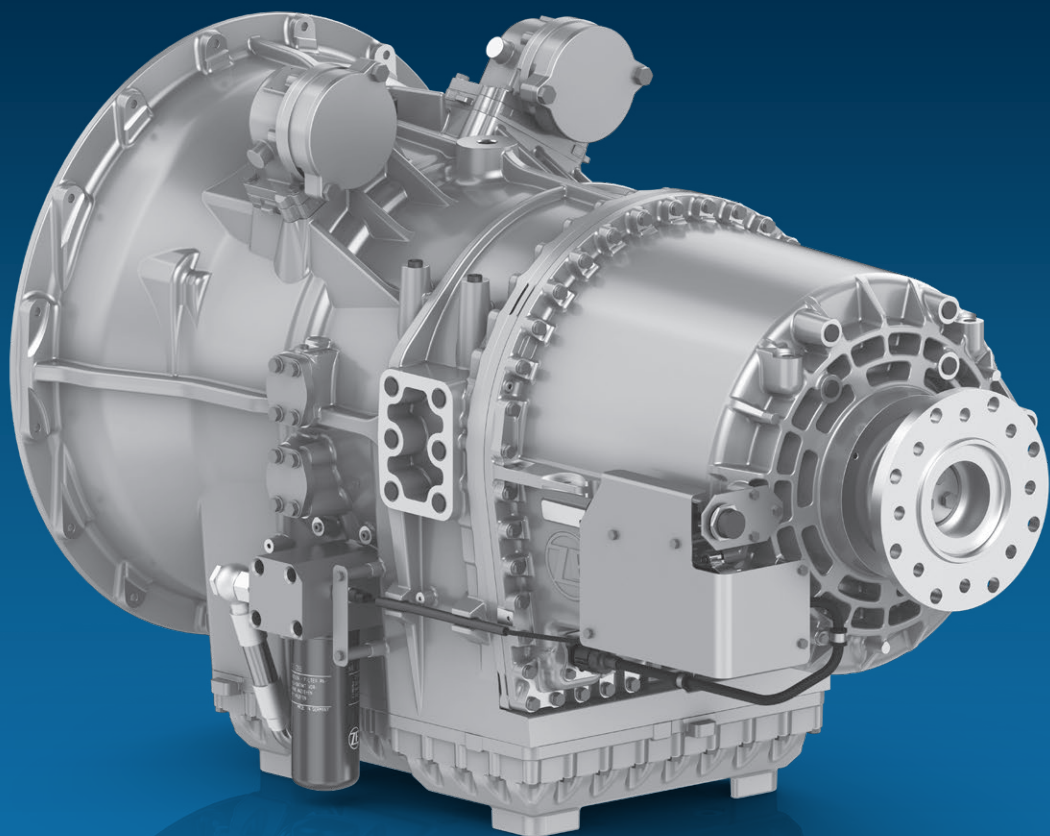

8 TX 3000 – The System

The 8 TX 3000 automatic transmission for well servicing: lightweight, powerful, and durable – designed for the application in high pressure pumping applications.

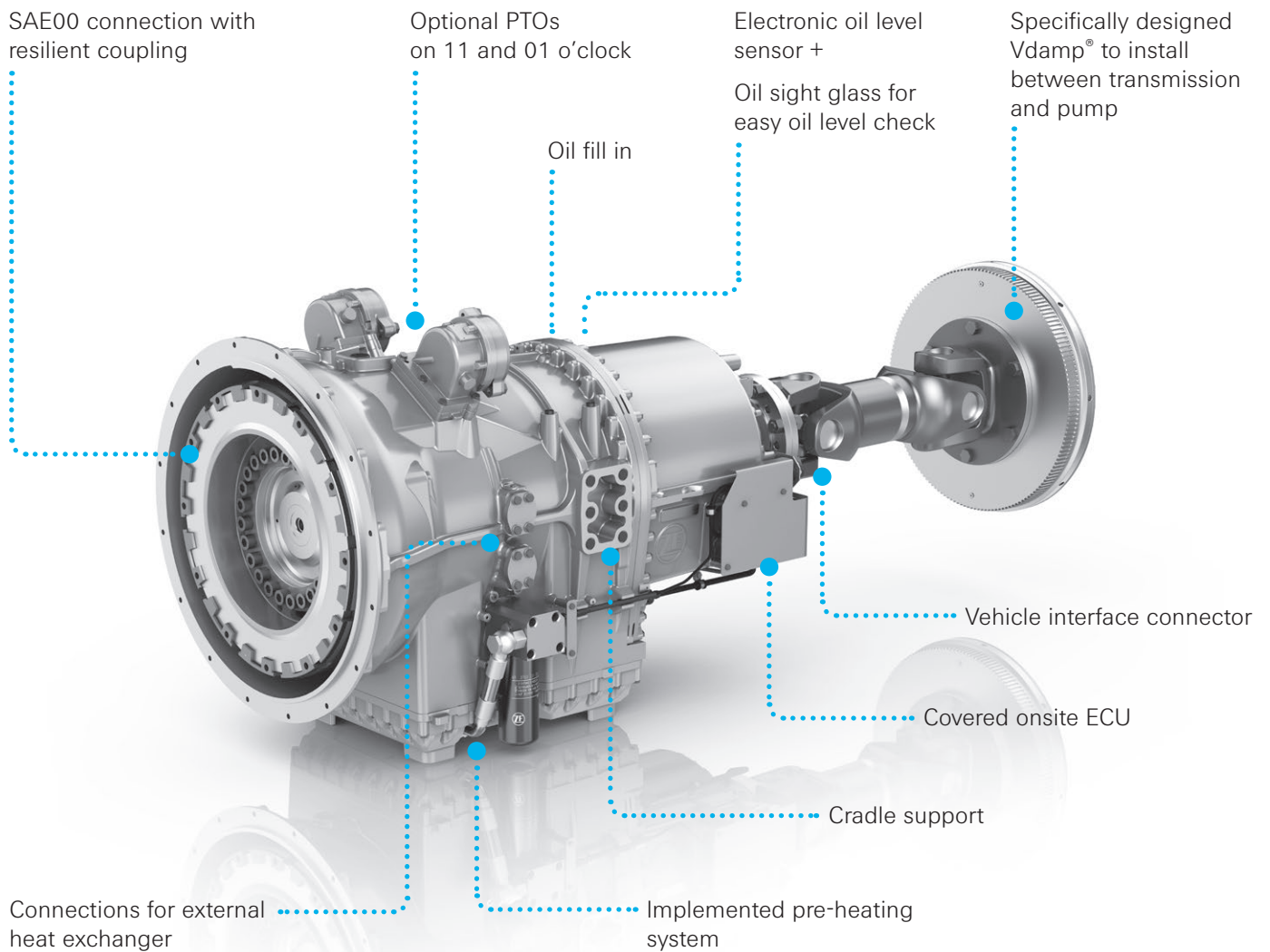

8 TX 3000

Maximum gross input power	3000 hp @ 1900 rpm
Maximum gross torque	11500 Nm / 8482 lbf-ft
Maximum starting torque	8000 Nm / 5900 lbf-ft @ 1500 rpm
Mounting	SAE 00 dry flywheel
2 PTOs available, capable of	150 hp / 100 kW each
PTO interface	SAE C & B Pads
Oil volume	approx. 80 liters / 21.13 gal (US)
Oil type	Engine oil (10W40 / 15W40)
Dry weight	1243 kg / 2740 lbs (without oil + PTO)

Standard ratios in gear

1	2	3	4	5	6	7	8
3.674	2.667	2.156	1.708	1.378	1.217	1.005	0.814

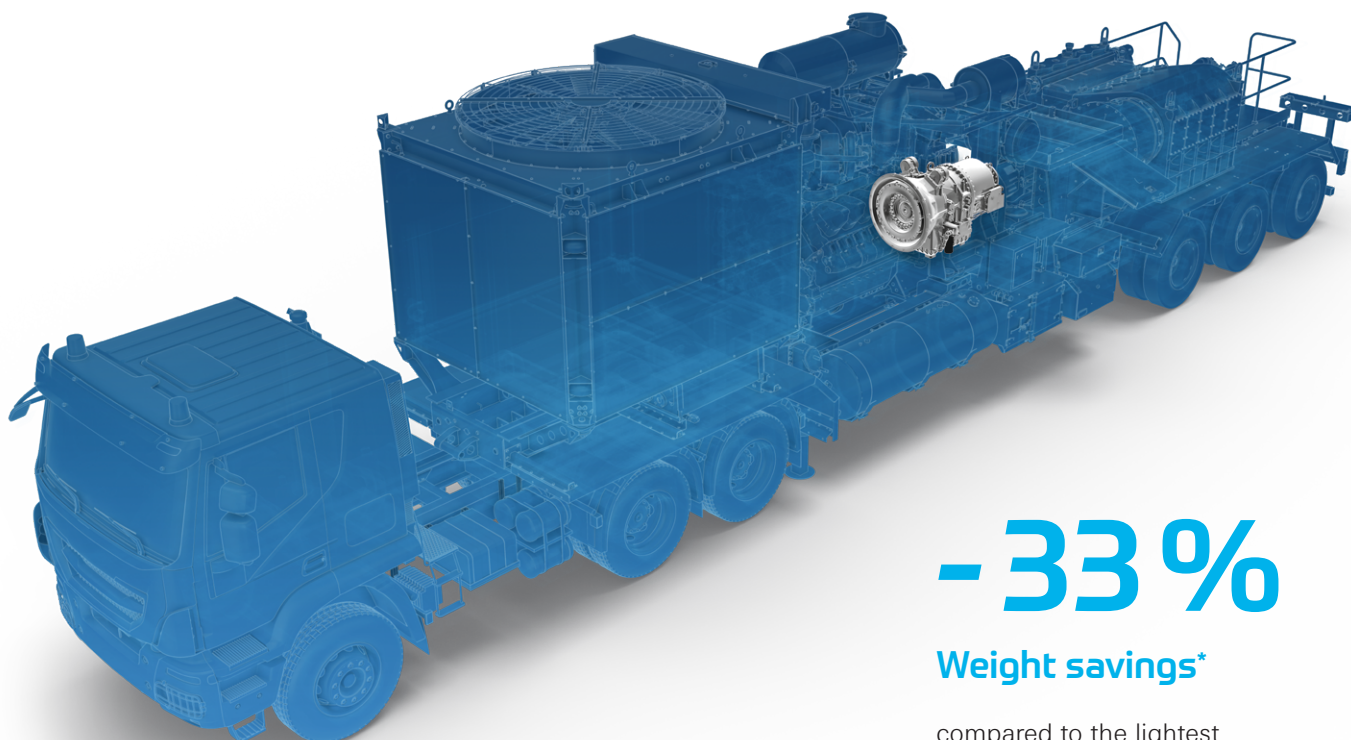

-33%

Weight savings*

compared to the lightest competitor product of the same class

ZF Group

Industrial Technology
Marine & Special Driveline Technology
Ehlersstr. 50
88046 Friedrichshafen / Germany
Phone +49 7541 77-8316
special-transmission@zf.com

Get to know more about our
transmissions for special applications:



www.zf.com/special-transmission



www.zf.com/8tx