

ENHANCED EASY-STOP™ TRAILER ABS WITH PLC

2S/1M BASIC, 2S/2M STANDARD,
2S/2M, 4S/2M AND 4S/3M PREMIUM

MAINTENANCE MANUAL

2S/1M BASIC

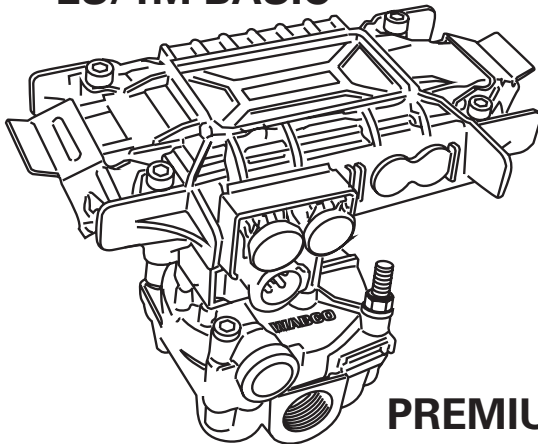

STANDARD

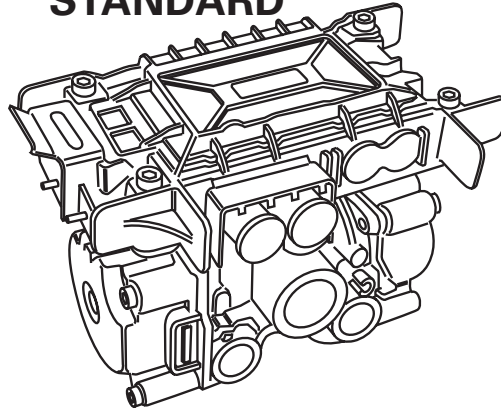

PREMIUM

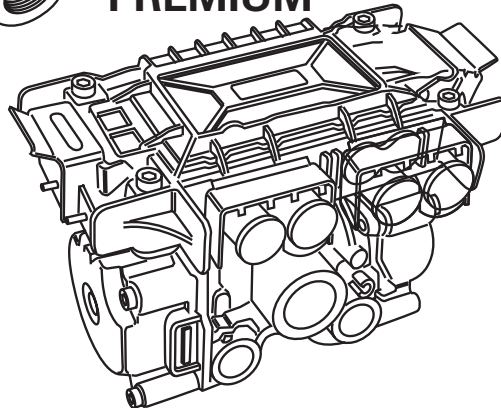

MM0180

WABCO

Table of Contents

Table of Contents

| | | |
|----------|--|-----------|
| 1 | General Information | 5 |
| 1.1 | Symbols Used in this Document..... | 5 |
| 1.2 | How to Obtain Additional Maintenance, Service and Product Information..... | 6 |
| 1.3 | How to Obtain Parts and Kits..... | 6 |
| 1.4 | WABCO TOOLBOX PLUS™ Software..... | 6 |
| 1.5 | WABCO Academy..... | 6 |
| 1.6 | WABCO Online Product Catalog..... | 6 |
| 1.7 | Your Direct Contact to ZF CVS..... | 7 |
| 2 | Safety Information | 8 |
| 2.1 | Provisions for a safe work environment..... | 8 |
| 2.2 | Trailer Ground and Protection from Electrostatic Discharge (ESD)..... | 9 |
| 3 | Introduction | 11 |
| 3.1 | Identifying Enhanced Easy-Stop..... | 11 |
| 3.2 | Enhanced Easy-Stop Trailer ABS Parts..... | 12 |
| 3.3 | What Is WABCO's Enhanced Easy-Stop Trailer ABS?..... | 12 |
| 3.4 | System Configuration..... | 12 |
| 3.5 | How Trailer ABS Works..... | 13 |
| 3.6 | System Components..... | 13 |
| 4 | ABS Questions and Answers | 18 |
| 4.1 | The ECU..... | 18 |
| 4.2 | Power Line Carrier (PLC)..... | 18 |
| 4.3 | ABS Indicator Lamps..... | 19 |
| 4.4 | Types of Faults..... | 21 |
| 4.5 | Frequently Asked Questions..... | 22 |
| 5 | System Configurations | 23 |
| 5.1 | Enhanced Easy-Stop Installation Diagrams..... | 23 |
| 5.2 | Power Cable Wiring Diagrams..... | 34 |
| 6 | Diagnostics | 36 |
| 6.1 | Important PLC Information for Blink Code Diagnostics..... | 36 |
| 6.2 | TOOLBOX PLUS™ SOFTWARE..... | 37 |
| 6.3 | TOOLBOX PLUS™ SOFTWARE SCREENS..... | 38 |
| 6.4 | Initial Power-up Check..... | 44 |
| 6.5 | Power and Ground Checks..... | 44 |
| 6.6 | Blink Code Diagnostics..... | 45 |

| | | |
|-----------|---|------------|
| 7 | Component Replacement..... | 71 |
| 7.1 | Wheel Speed Sensor | 72 |
| 7.2 | ABS Relay Valve | 73 |
| 7.3 | ECU/Valve Assembly | 74 |
| 8 | Sensor Adjustment and Component Testing. | 80 |
| 8.1 | How to Test Wheel Speed Sensors | 80 |
| 8.2 | Check ABS Functions | 81 |
| 8.3 | ABS External Modulator Valve | 81 |
| 8.4 | End of Line Testing | 81 |
| 8.5 | End of Line Testing without TOOLBOX PLUS™ Software 12.2 or Higher | 89 |
| 8.6 | Inspect the Sensor and Air Line Installation (2S/2M Standard) | 90 |
| 8.7 | Trailer Identification..... | 95 |
| 9 | Troubleshooting..... | 96 |
| 9.1 | Lift Axle Troubleshooting..... | 96 |
| 9.2 | Tag Axle Troubleshooting..... | 112 |
| 9.3 | Rear Aero Auto Deployment System (RAADS) Troubleshooting..... | 122 |
| 9.4 | Tire Inflation Communication System Troubleshooting..... | 126 |
| 9.5 | Door Ajar System Troubleshooting – Trailer ABS | 129 |
| 9.6 | Activating the Tire Inflation and Door Ajar Systems Option with TOOLBOX PLUS™ Software..... | 132 |
| 10 | Appendix I..... | 135 |
| 10.1 | Trailer ABS Indicator Lamp on Vehicle Dash | 135 |
| 11 | Appendix II..... | 137 |
| 11.1 | Cable Routing Guideline | 137 |
| 11.2 | Cable Strain Relief Guidelines | 138 |

Edition 1
Version 2 (04.2026)
MM0180 (en)

This publication is not subject to any update service. Information contained in this publication was in effect at the time the publication was approved for printing and is subject to change without notice or liability. ZF CV Systems North America LLC reserves the right to revise the information presented or to discontinue the production of parts described at any time.

You will find the current edition at: <https://zf.com/cv/downloads>

General Information

1 General Information

1.1 Symbols Used in this Document

DANGER

Description of an immediate situation which will result in irreversible injury or death if the warning is ignored.

WARNING

Description of a possible situation which may result in irreversible injury or death if the warning is ignored.

CAUTION

Description of a possible situation which may result in irreversible injury if the warning is ignored.

NOTICE

Description of a possible situation which may result in material damage if the warning is ignored.

 Important information, notices and/or tips

 Reference to information on the Internet

Descriptive text

– Action step

1. Action step 1 (in ascending order)

2. Action step 2 (in ascending order)

⇒ Result of an action

• Listing

 Indicating the use of a tool / WABCO tool

General Information

1.2 How to Obtain Additional Maintenance, Service and Product Information

If you have any questions about the material covered in this publication, or for more information about the WABCO product line, please contact WABCO Customer Care Center at 855-228-3203, by email at wabconacustomercenter@zf.com, or visit our website: www.zf.com/cv.

Refer to the Society of Automotive Engineers (SAE) website to find all current SAE documents and standards applicable to WABCO products (such as SAE J447 and SAE J908 at www.sae.org).

Refer to the National Highway Traffic Safety Administration (NHTSA) website to find all current documents referenced in the manual at www.nhtsa.gov.

1.3 How to Obtain Parts and Kits

Contact the WABCO Customer Care Center at 855-228-3203 (United States and Canada); 800-953-0248 (Mexico). Email: wabconacustomercenter@zf.com.

1.4 WABCO TOOLBOX PLUS™ Software

TOOLBOX PLUS™ Software provides PC diagnostic for WABCO products and can be purchased and downloaded from <https://wabco.snapon.com>.

The software User Guide, MM19047 can be obtained by visiting our Literature Center.



Purchase and Download TOOLBOX PLUS™

<https://wabco.snapon.com>



ZF Commercial Vehicle Literature Center

<https://zf.com/cvliterature>

1.5 WABCO Academy



www.wabco-academy.com

1.6 WABCO Online Product Catalog



www.wabco-customercenter.com

General Information

1.7 Your Direct Contact to ZF CVS

ZF CV Systems North America LLC

1220 Pacific Drive
Auburn Hills, MI 48326

Customer Care Center: (855) 228-3203

www.zf.com/cv

www.wabconacustomer care@zf.com

Safety Information

2 Safety Information

2.1 Provisions for a safe work environment

- Only experienced, trained and qualified automotive technicians may carry out work on the vehicle.
- Read this publication carefully.
- Follow all warnings, notices and instructions to avoid personal injury and property damage.
- Always abide by the vehicle's Original Equipment Manufacturer (OEM) specifications and instructions.
- Observe all accident regulations of the repair facility as well as regional and national regulations.
- The workplace should be dry, sufficiently lit and ventilated.
- Use personal protective equipment if required (safety shoes, protective goggles, respiratory protection and ear protectors).

Read and observe all Danger, Warning and Caution hazard alert messages in this publication. They provide information that can help prevent serious personal injury, damage to components, or both.

WARNING

To prevent serious eye injury, always wear safe eye protection when you perform vehicle maintenance or service.

WARNING

Park the vehicle on a level surface. Block the wheels to prevent the vehicle from moving. Support the vehicle with safety stands. Do not work under a vehicle supported only by jacks. Jacks can slip or fall over. Serious personal injury and damage to components can result.

WARNING

This product can expose you to chemicals including Nickel, which is known to the State of California to cause cancer and birth defects or other reproductive harm. For more information, go to www.P65Warnings.ca.gov.

Safety Information

2.2 Trailer Ground and Protection from Electrostatic Discharge (ESD)

CAUTION

Unintended voltages induced into the electronic control unit can damage the ECU. Disconnect all connectors from the ECU before you perform any welding, electrostatic painting, or any other activity that applies high voltage to the vehicle frame. Refer to the equipment manufacturer's recommended instructions for correct procedures.

Prevent potential resistance differences in grounding between components (such as axles) and the vehicle frame (chassis).

Make sure that the resistance between metallic parts of the components connected to the trailer frame is less than 10 Ohm ($< 10\Omega$).

Connect moving or insulated vehicle parts (such as axles) in a electrically conductive manner with the frame.

Ensure a secure and adequate chassis ground at the J560 seven-way connector ground pin on the trailer.

Use electrically conductive bolted connections when fastening the ECUs to the trailer frame.

2.2.1 Welding Work on the Trailer

Disconnect power to the trailer.

Disconnect all cable connections to devices and components and protect the plug-ins and connections from contamination and humidity.

Always connect the grounding electrode directly with the metal next to the welding position when welding, to prevent magnetic fields and current flow via the cable or components.

Make sure that grounding connections are robust by removing paint or rust at the connection points.

Prevent heat influences from the welding activity on devices and cabling when welding.

During Electrostatic Painting the Trailer Frame or Bogie: Disconnect all cable connections to devices and components and protect the plug-ins and connections from contamination and humidity.

Safety Information

2.2.2 Dielectric Grease

Enhanced Easy-Stop ECUs and ECU/valve assemblies with a production date of 0523 or later no longer have dielectric grease applied. A thin coating of Nyogel 760G can be applied to the 8-pin terminals of the power and modulator cables as well as the male terminal pins on the sensor extension cable. Nyogel 760G is the only grease approved for use on the power, modulator and sensor extension cables of the Enhanced Easy-Stop ABS System. Ensure the greased cables are free from dirt and debris before installation, as the grease readily collects dirt, debris or dust, which may inhibit functionality.

2.2.3 Vehicle Electrical Grounding Guidelines

Ensure that the vehicle includes a correct common chassis ground point. A common chassis ground point connects the trailer frame/chassis to the ground pin of the J560 seven-way connector and will protect the vehicle electrical system from unwanted electrical noise.

Common chassis ground can be verified by measuring the resistance between the J560 ground pin and the vehicle chassis (or frame) and confirming that the resistance is less than 10 ohm ($< 10 \Omega$). If this is not the case, the electrical contact at the common chassis ground point is not sufficient or not present. If a common chassis ground point is present, but not sufficient, ensure that there is no paint or debris inhibiting electrical contact at the ground point. If a common chassis ground point is not present, WABCO requires adding one. Consult your trailer manufacturer (OEM) for further instructions on how to perform this task. This ensures that the trailer OE warranty is not voided.



Do not add more than one common chassis ground point (connecting the J560 ground pin to the chassis) to avoid potential ground shifts within the vehicle electrical system.

Additionally, all standard trailer components, such as axles, should also be electrically connected to the common chassis ground. If the axles are not correctly grounded to the chassis, a ground strap electrically connecting the axle to the chassis must be added to ensure adequate protection from unwanted electrical noise. This can be verified by measuring the maximum resistance between the vehicle chassis/frame and the other trailer component, then confirming that the resistance is less than 10 ohm ($< 10 \Omega$).

For more details concerning correct vehicle grounding, reference SAE standard J1908.

Introduction

3 Introduction

This manual contains service and diagnostic information for WABCO Enhanced Easy-Stop™ Trailer ABS with Power Line Carrier (PLC) capability.

3.1 Identifying Enhanced Easy-Stop

To identify Enhanced Easy-Stop, check the identification tag on the Electronic Control Unit (ECU). The part numbers for Enhanced Easy-Stop systems are:

- 400 500 101 0 (2S/1M Basic for standard trailers)
- 400 500 102 0 (2S/2M Standard)
- 400 500 103 0 (2S/2M, 4S/2M and 4S/3M Premium)
- 400 500 104 0 (2S/1M Basic for dollies and steerables)
- 400 500 105 0 (2S/2M, 4S/2M and 4S/3M InfoLink)
- 400 500 106 0 (2S/1M Basic for InfoLink)

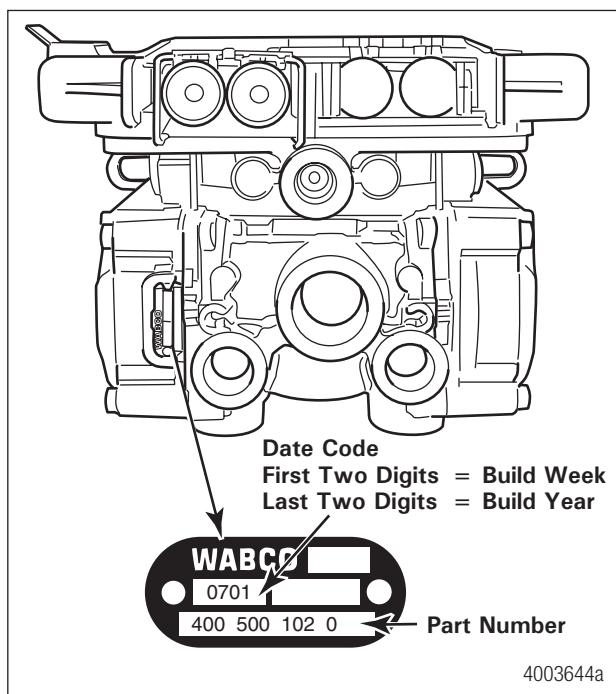

If you are not able to identify the version and need to request service literature, please visit zf.com/cvliterature. Otherwise, contact the WABCO Customer Care Center at 855-228-3203.

This manual does not contain Original Equipment Manufacturer (OEM) installation instructions. New installations require the following documentation:

- Enhanced Easy-Stop Basic (2S/1M): TP20212
- Enhanced Easy-Stop Standard (2S/2M): TP20213
- Enhanced Easy-Stop Premium (2S/2M, 4S/2M and 4S/3M): TP20214

Introduction

3.2 Enhanced Easy-Stop Trailer ABS Parts

Parts book PB96133 lists WABCO Enhanced Easy-Stop replacement parts. To obtain a copy, go to zf.com/cvliterature.

For warranty information refer to SP1375 which can be found at zf.com/cvliterature. For further information, contact the WABCO Customer Care Center at 855-228-3203.

3.3 What Is WABCO's Enhanced Easy-Stop Trailer ABS?

WABCO's Enhanced Trailer ABS is an electronic, self-monitoring system that works with standard air brakes. In addition, Enhanced Easy-Stop includes Power Line Carrier (PLC) capability. PLC information is included in the ABS Q & A Section of this manual. The major components of the system are the **Electronic Control Unit (ECU)/Valve Assembly**, **ABS modulator valve (for 3M systems)**, **tooth wheel and wheel speed sensor**.

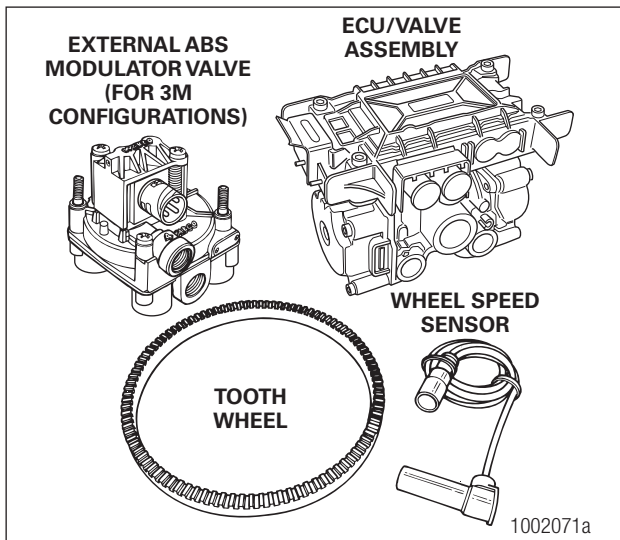

3.4 System Configuration

The ABS **configuration** defines the number of wheel speed sensors and ABS modulator valves used in a system. For example, a **2S/1M** configuration includes two wheel sensors and one ABS modulator valve. A **2S/2M** configuration includes two wheel sensors and two ABS modulator valves. A **4S/2M** configuration includes four wheel sensors and two ABS modulator valves.

There is a specific ECU/valve assembly for each configuration:

- For 2S/1M Basic, the assembly consists of an ECU and a single modulator valve assembly
- For 2S/2M Standard and 4S/2M, the assembly consists of an ECU and a dual modulator valve assembly (one valve that combines the function of two modulator valves). The 2S/2M Standard valve has only two sensor outlets and cannot be upgraded.
- A 4S/3M premium configuration consists of an ECU/dual modulator valve assembly and one external ABS modulator valve.

Introduction

3.5 How Trailer ABS Works

WABCO ABS is an electronic system that monitors and controls wheel speed during braking. The system works with standard air brake systems.

ABS monitors wheel speeds at all times and controls braking during wheel lock situations. The system improves vehicle stability and control by reducing wheel lock during braking.

The ECU receives and processes signals from the wheel speed sensors. When the ECU detects a wheel lockup, the unit activates the appropriate modulator valve, and air pressure is controlled.

In the event of a malfunction in the system, the ABS in the affected wheel(s) is disabled; that wheel still has normal brakes. The other wheels keep the ABS function.

Two ABS indicator lamps (one on the dash and one on the side of the trailer) let drivers know the status of the system.

3.6 System Components

3.6.1 ECU/Valve Assembly

- 12 volt
- Integrated ECU and ABS relay valve
 - ECU and valve assembly are serviceable items.
- The ECU/Valve Assembly may be mounted with the sensors facing either the front or rear of the trailer.

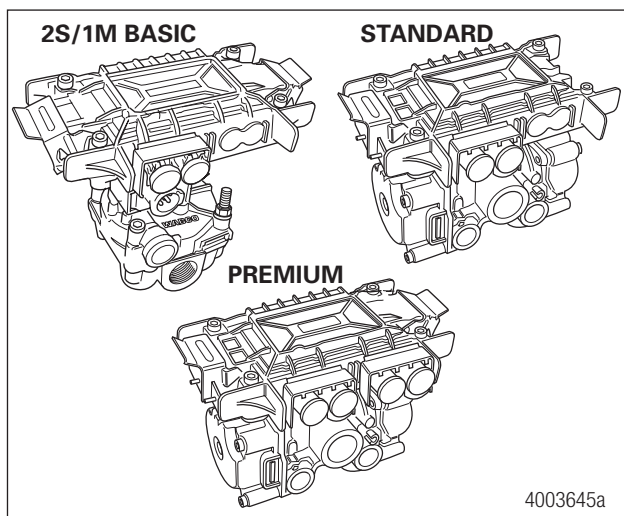

3.6.2 ABS External Modulator Valve

- Controls air pressure to the brake chambers where it is plumbed.
- During ABS operation, the valve adjusts air pressure to the brake chambers to control braking and prevent wheel lock.
- Used in conjunction with ECU/Valve Assembly for 3M systems.

Introduction

3.6.3 Sensor with Molded Socket

- Measures the speed of a tooth wheel rotating with the vehicle wheel.
- Produces an output voltage proportional to wheel speed.

3.6.4 Sensor with Molded Socket

- Holds the wheel speed sensor in close proximity to the tooth wheel.

3.6.5 Tooth Wheel

- A machined ring mounted to the machined surface on the hub of each ABS-monitored wheel.

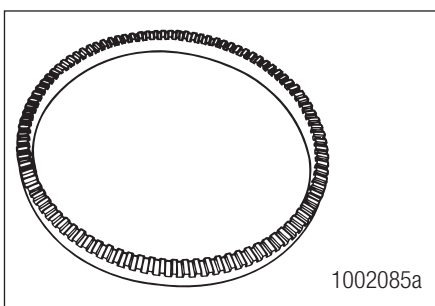
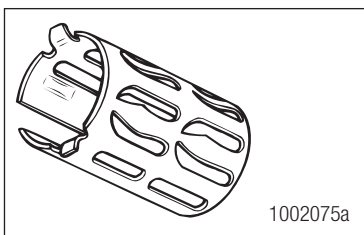
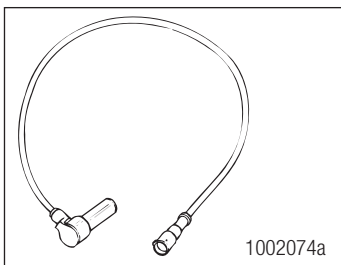
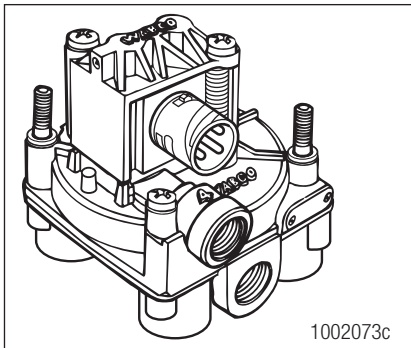

Introduction

3.6.6 Cables for Enhanced Easy-Stop

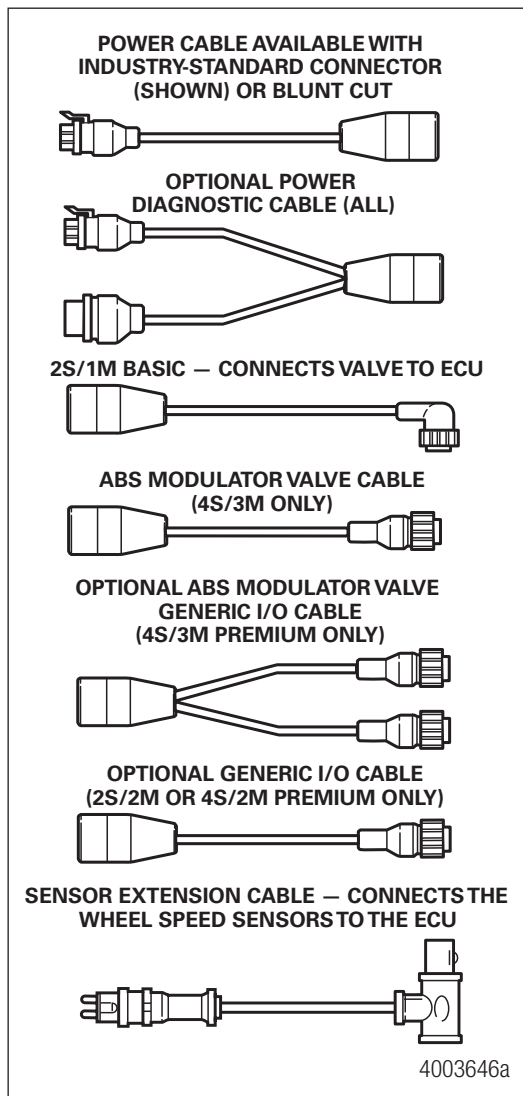

3.6.7 Enhanced Easy-Stop Trailer ABS Indicator

- Provides information about the operation of the ABS indicator lamp and illustrates blink code fault locations.
- Label is self-adhesive and is mounted on the trailer near the ABS indicator lamp.
- If there is no warning label on your trailer, let your supervisor know. Labels are available from WABCO. Ask for Part Number TP95172.

Introduction

3.6.8 TOOLBOX PLUS™ Software

TOOLBOX PLUS™ Software is a PC-based diagnostics program that can display fault codes, wheel speed data, test individual components, verify installation wiring and is required to perform a sign-off for the Enhanced Easy-Stop with PLC installation.

WABCO TOOLBOX PLUS™ Software, Version 12.2 (or higher) supports Enhanced Easy-Stop with PLC. TOOLBOX PLUS™ Software is available for purchase via download 24 hours a day, seven days a week on www.wabco-snap-on.com. TOOLBOX PLUS™ supports Enhanced Easy-Stop with PLC and requires a PC/Laptop with Windows 7, 8, 10.

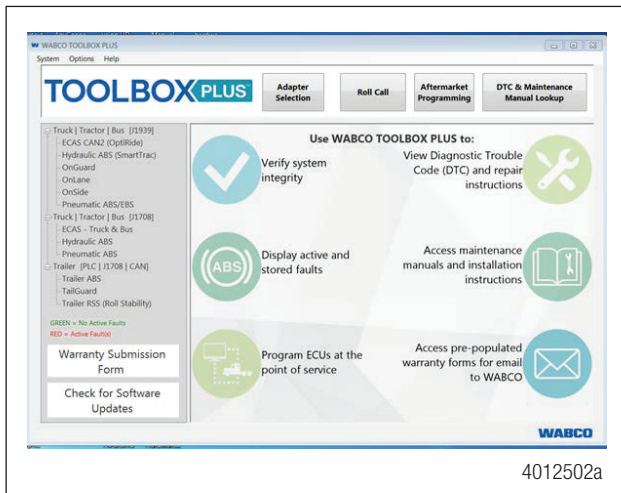

3.6.9 PLC/J1708 Adapter

- Simulates the tractor ABS lamp, ensuring that the trailer ABS is capable of “lighting the light.”
- Simulates the trailer ABS lamp, ensuring that the tractor is capable of “lighting the light.”
- Use as a trailer/tractor tester to ensure that PLC is functioning correctly.

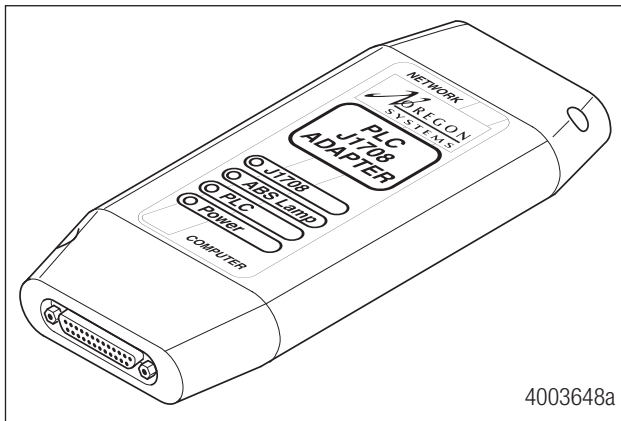

Available from Noregon Systems, 336-768-4337

Introduction

3.6.10 MPSI Pro-Link® 9000 Diagnostic Tool

- Provides diagnostic and testing capability for ABS components.
- Requires a Multiple Protocol Cartridge (MPC) and WABCO applications card, version 2.0 or higher, for use with Enhanced Easy-Stop with PLC.

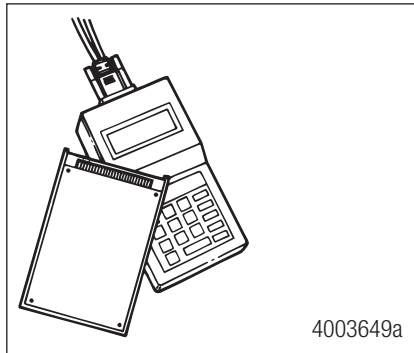

3.6.11 DLA + PLC Adapter

- Simulates the trailer ABS lamp, ensuring that the tractor is capable of “lighting the light.”
- Use as a trailer/tractor tester to ensure that PLC is functioning correctly.
- Currently replaced by the heavy duty trailer diagnostic adapter.

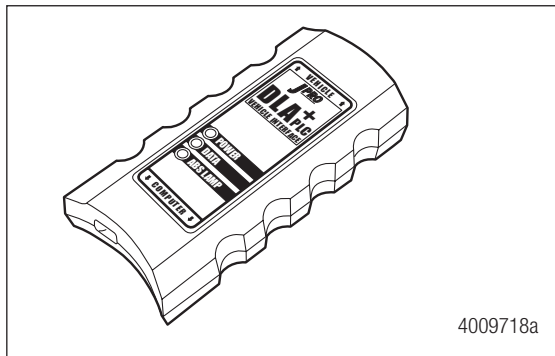

3.6.12 Heavy Duty Trailer Diagnostic Adapter

- Simulates the trailer ABS lamp, ensuring that the tractor is capable of “lighting the light.”
- Use as a trailer only tester to ensure that PLC is functioning correctly.

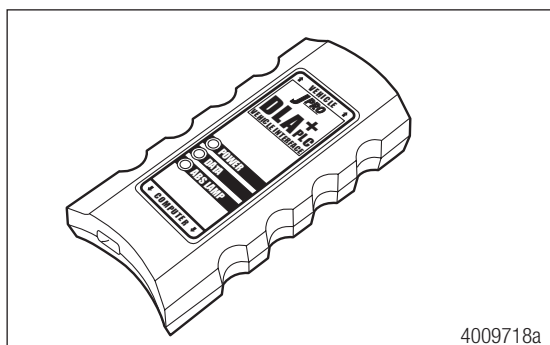

Available from jprofleetproducts.com, SKU: 122511

ABS Questions and Answers

4 ABS Questions and Answers

This section contains ABS questions and answers.

4.1 The ECU

How do you activate the ECU?

In a constant-powered system, the ECU activates and then begins a self-diagnostic check of the system when you turn the ignition ON. In a stoplight-powered system, the ECU activates when you apply the brakes. All trailers manufactured on or after March 1, 1998 will be equipped with ABS that has constant power capability with stoplight power as back-up.

How does the ECU respond to a wheel approaching lock-up?

The ECU directs the ABS relay valve to function as a modulator valve and adjust air pressure to the chambers up to five times a second. This pressure adjustment allows a wheel (or wheels) to rotate without locking.

4.2 Power Line Carrier (PLC)

What is PLC communications?

PLC stands for Power Line Carrier, which is a method used to communicate information by multiplexing data on the same wire used for the ABS electrical power. PLC communications convert signal message data to a radio frequency (RF) signal on top of the +12V power line providing electrical power to the trailer.

What is multiplexing?

Multiplexing means communicating multiple signals or messages on the same transmission media. This provides an efficient and cost effective means by decreasing the number of wires and connectors which otherwise would be needed. Without multiplexing, it could take several wires and connections in order to transmit several different signals to various locations on a vehicle, but with multiplexing these wires and connectors can be significantly reduced.

Why add PLC technology to tractor and trailer ABS?

By adding PLC technology to the tractor and trailer ABS the industry is able to have the most cost effective means to meet the March 1, 2001 FMVSS-121 in-cab trailer indicator lamp mandate with no additional external hardware, harnesses or connectors. Additionally, this capability of communicating other information between tractor and trailers provides many more opportunities to further improve productivity and safety.

How does it work?

The trailer ABS with PLC takes message information to be sent to the tractor and converts it to an RF signal. The signal is then sent over the trailer ABS power line (blue wire) and the tractor ABS with PLC receives the signal. Messages can also be sent from the tractor to the trailer via PLC.

What if a tractor is equipped with PLC technology and the trailer is not, or vice versa? Can you drive the combination safely in that situation?

Absolutely. If the tractor is equipped with PLC and the trailer is not, or vice-versa, your ABS in-cab trailer indicator lamp will not illuminate, but your ABS will continue to function as normal. To ensure that the trailer ABS is functioning correctly, the trailer ABS indicator lamp mounted on the trailer should be utilized.

What if a tractor has one manufacturer's ABS with PLC and the trailer has another manufacturer's ABS with PLC? Will the two systems be compatible and operate the trailer ABS lamp as expected?

Yes. ABS with PLC from different manufacturers are designed to be compatible by controlling the trailer ABS lamp according to the FMVSS-121 standard, even when systems from different manufacturers are connected to each other. However, certain features beyond the control of the trailer ABS indicator lamp may

ABS Questions and Answers

or may not be supported by all devices communicating via PLC. SAE task forces continue to standardize common messages so that maximum compatibility may exist in the future.

How do I diagnose PLC?

PLC can be diagnosed over the J1587/J1708 diagnostic connector on the tractor and trailer using tools designed for PLC diagnostics.

Can I use blink code diagnostics on Enhanced Easy-Stop to diagnose PLC?

Yes. Section 5 of this manual describes the method of performing a blink code check using Constant Power (ignition activation). Blink Code 17 indicates a PLC failure.

If PLC does not seem to be operating correctly, but I don't get a Blink Code 17 when I run a blink code check, what else could be wrong?

If there is no Blink Code 17, the ECU is functioning correctly and does not need to be replaced; however, there could be a problem in the trailer's wiring harness. Check the wiring system and make the necessary repairs. If the problem persists, contact the WABCO Customer Care Center at 855-228-3203.

4.3 ABS Indicator Lamps



When replacing the bulb, to ensure correct lamp operation use an incandescent type DOT-approved lamp, or a LED with integral load resistor.

4.3.1 ABS Indicator Lamp (on Dash)

With Enhanced Easy-Stop there are two ABS indicator lamps; one on the vehicle dash and one on the side of the trailer. Refer to Appendix I for information about the operation of this lamp.

4.3.2 ABS Indicator Lamp (on Trailer)

What is the function of the ABS indicator lamp?

The indicator lamp enables a driver to monitor the ABS at all times. Refer to the OEM operating manual for the mounting location of the indicator lamp.

How does the indicator lamp operate?

How the indicator lamp operates depends on whether the ABS is powered by stoplight or constant power:

- If the trailer was manufactured prior to February 28, 1998, or was manufactured outside of the United States, the ABS may be either stoplight or constant powered.
- If the trailer was manufactured March 1, 1998 or later — and was manufactured in the United States — it will have constant power capability. This is mandated by Federal Motor Vehicle Safety Standard (FMVSS) 121.

Check your vehicle specification sheet to determine the type of ABS power. Table B in this section illustrate indicator lamp operation on stoplight and constant powered ABS systems.

An ECU with part number 472 500 001 0 manufactured prior to September 1997 requires all sensed wheels to detect a 4 mph signal to shut off the ABS indicator lamp. Do not confuse this with a faulty ABS system. If the indicator lamp stays on when the brakes are applied to a moving vehicle, service the ABS system.

ABS Questions and Answers

Most trailers manufactured prior to February 1998 require that the brakes be applied to operate the ABS indicator lamp. If the indicator lamp stays on when the brakes are applied to a moving vehicle, service the ABS system.

What does the trailer ABS indicator lamp mean to service personnel?

The trailer ABS indicator lamp on the side of the trailer indicates the status of the trailer ABS. If it comes ON and stays ON when you apply the brakes to a moving vehicle, there is an ABS malfunction. It is normal for the lamp to come ON and go OFF to perform a bulb check, but it should not stay ON when the vehicle is moving above 4 mph. As with any safety system, it is important not to ignore this indicator. If the indicator lamp indicates a malfunction, the vehicle can be operated to complete the trip, but it is important to have it serviced as soon as possible using the appropriate maintenance manual to ensure correct braking performance and that the benefits of ABS remain available to your drivers. Typical ABS indicator lamp mounting locations are illustrated.

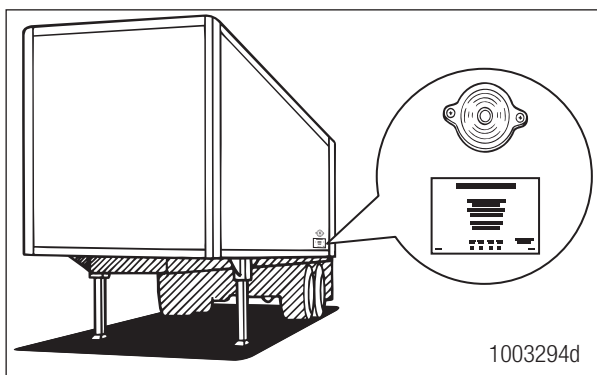

Typical ABS Indicator Lamp Mounting Location on Side of Trailer

For service information, contact the WABCO Customer Care Center at 855-228-3203.

Can you continue to operate a vehicle when the indicator lamp indicates a fault?

Yes. When a fault exists in the ABS, standard braking returns to the affected wheel, and the ABS still controls other monitored wheels. This lets you complete the trip. You should not ignore the indicator lamp and should have the vehicle serviced as soon as possible after the lamp comes ON and stays ON.

TABLE A: CONSTANT POWER

| System is Ignition Powered | | | | |
|----------------------------|----------|-----------------|--------------------|------------------------------------|
| Brakes | Ignition | Fault in System | Vehicle Speed | Indicator Lamps (Trailer and Dash) |
| Released | OFF | N.A. | N.A. | OFF |
| | ON | NO | Less than 4 mph | ON for 3 seconds, then go OFF. |
| | ON | NO | Greater than 4 mph | OFF |
| | ON | YES | N.A. | ON |
| Applied | OFF | NO | Less than 4 mph | ON for 3 seconds, then go OFF. |
| | OFF | YES | N.A. | ON |
| | ON | NO | Less than 4 mph | OFF |
| | ON | NO | Greater than 4 mph | OFF |
| | ON | YES | N.A. | ON |

ABS Questions and Answers

TABLE B: STOPLIGHT POWER

|  Stoplight power is designed to be for backup only for the ABS, so if the light is not functioning per the Constant Power table, the power and ground should be checked on the system. | | | |
|---|-----------------|--------------------|--|
| System Power Comes from Activating the Stoplight Circuit. | | | |
| Brakes | Fault in System | Vehicle Speed | Indicator Lamp |
| Released | N.A. | N.A. | OFF |
| Applied | NO | Less than 4 mph | ON for 3 seconds, then goes OFF. |
| Applied | NO | Greater than 4 mph | Flashes once, then stays OFF for remainder of the brake application. |
| Applied | YES | N.A. | ON |

4.4 Types of Faults

What is a fault in the system?

A fault in the system is a problem that can exist in the ABS or in the system's components. Faults can be either existing faults or intermittent stored faults.

What is an existing fault?

An **existing** fault is a problem that exists currently in the system. For example, a damaged sensor cable is an existing fault that the ECU will detect and store into memory until you identify the cause, repair the cable and clear the fault from the ECU.

What is an intermittent fault?

An **intermittent** fault is a problem that usually occurs only under certain driving conditions. For example, the ECU may detect a loose cable or wire or receive an erratic signal from a wheel sensor. Since intermittent faults can be unpredictable and may only happen periodically, you can use information stored in ECU memory to find and correct the loose cable or wire. An intermittent fault cannot be retrieved using blink codes.

Is an intermittent fault difficult to locate and repair?

It can be, because you may not be able to easily find the cause of the problem. WABCO recommends that you write down intermittent faults to help you isolate a fault that recurs over a period of time.

Can the ECU store more than one fault in memory?

Yes. The ECU retains existing and intermittent faults in memory even when you turn OFF the power to the ECU.

What if the ECU finds a fault in an ABS component during normal operation?

If the ECU senses a fault in the system (with an ABS valve, for example), the ECU turns the trailer ABS indicator lamp on and returns the wheel controlled by that valve to standard braking. Or, if the ECU finds a fault with one wheel speed sensor in a system that has four sensors on a tandem axle, the ECU uses information from the other sensor on the same side of the tandem to ensure continuous ABS function. The ECU continues to provide full ABS function to the wheels unaffected by system faults. However, the ECU will turn the trailer ABS indicator lamp on to tell the driver a fault has been detected in the system.

ABS Questions and Answers

4.5 Frequently Asked Questions

What is the crack pressure of the ABS valve?

The pressure at which the ABS valve opens to allow air pressure to the wheel ends is 3 to 4 psi on the signal port of the valve.

What can cause the trailer to bounce up and down when the service brakes are applied?

It is possible the ABS is getting signal from the sensor and tone ring that it is going into an ABS event. If the issue is more noticeable when the trailer is unloaded, it is possible the trailer has worn suspension components that can cause the ABS to react and go into an ABS event. Review with the trailer suspension manufacturer.

Why are my brake lights on dimly any time the trailer is powered up?

If the vehicle is equipped with LED brake lights and there is no resistor in the circuit, you will get unwanted illumination of the lights all the time. The 12v LED or circuit must have a resistor installed to prevent them from illuminating all the time.

System Configurations

5 System Configurations

5.1 Enhanced Easy-Stop Installation Diagrams

With Enhanced Easy-Stop, Standard 2S/2M and Premium 2S/2M, 4S/2M and 4S/3M sensor location designations will change depending on how the ECU/dual modulator valve assembly is mounted. It may be mounted facing either the front or the rear of the trailer. It is important that you identify the location of these sensors before beginning any diagnostics. Sensor locations for both front and rear-facing installations are depicted in Figures 5.1 through 5.10.



Sensor locations for the 2S/1M Basic will not change.

| Configuration | Figure |
|---|-------------|
| 2S/1M Basic ECU | Figure 5.1 |
| 2S/2M Standard Mounted with Sensors Facing Front of Trailer | Figure 5.2 |
| 2S/2M Standard Mounted with Sensors Facing Rear of Trailer | Figure 5.3 |
| 2S/2M Premium Mounted with Sensors Facing Front of Trailer | Figure 5.4 |
| 2S/2M Premium Mounted with Sensors Facing Rear of Trailer | |
| 4S/2M Premium Mounted with Sensors Facing Front of Trailer | Figure 5.5 |
| 4S/2M Premium Mounted with Sensors Facing Rear of Trailer | |
| 4S/2M Premium — Typical Tri-Axle — Mounted with Sensors Facing Front of Trailer | Figure 5.6 |
| 4S/2M Premium — Typical Tri-Axle — Mounted with Sensors Facing Rear of Trailer | |
| 4S/2M Premium — Typical Axle Control Installation — Mounted with Sensors Facing Front of Trailer | Figure 5.7 |
| 4S/2M Premium — Typical Axle Control Installation — Mounted with Sensors Facing Rear of Trailer | |
| 4S/3M Premium — Typical Tri-Axle with Front Lift — Mounted with Sensors Facing Front of Trailer | Figure 5.8 |
| 4S/3M Premium — Typical Tri-Axle with Front Lift — Mounted with Sensors Facing Rear of Trailer | |
| 4S/3M Premium — Typical Tri-Axle — Valve Mounted with Sensors Facing Front of Trailer | Figure 5.9 |
| 4S/3M Premium — Typical Tri-Axle — Valve Mounted with Sensors Facing Rear of Trailer | |
| 4S/3M Premium — Typical Four Axle Pull Trailer — Valve Mounted with Sensors Facing Front of Trailer | Figure 5.10 |
| 4S/3M Premium — Typical Four Axle Pull Trailer — Valve Mounted with Sensors Facing Rear of Trailer | |

System Configurations

5.1.1 Typical Easy-Stop Trailer ABS installation are illustrated in Figure 5.1 through 5.10:

i WABCO recommends placing sensors on the axle that will provide the most braking performance. The suspension manufacturer can provide this information.

Fig. 5.1

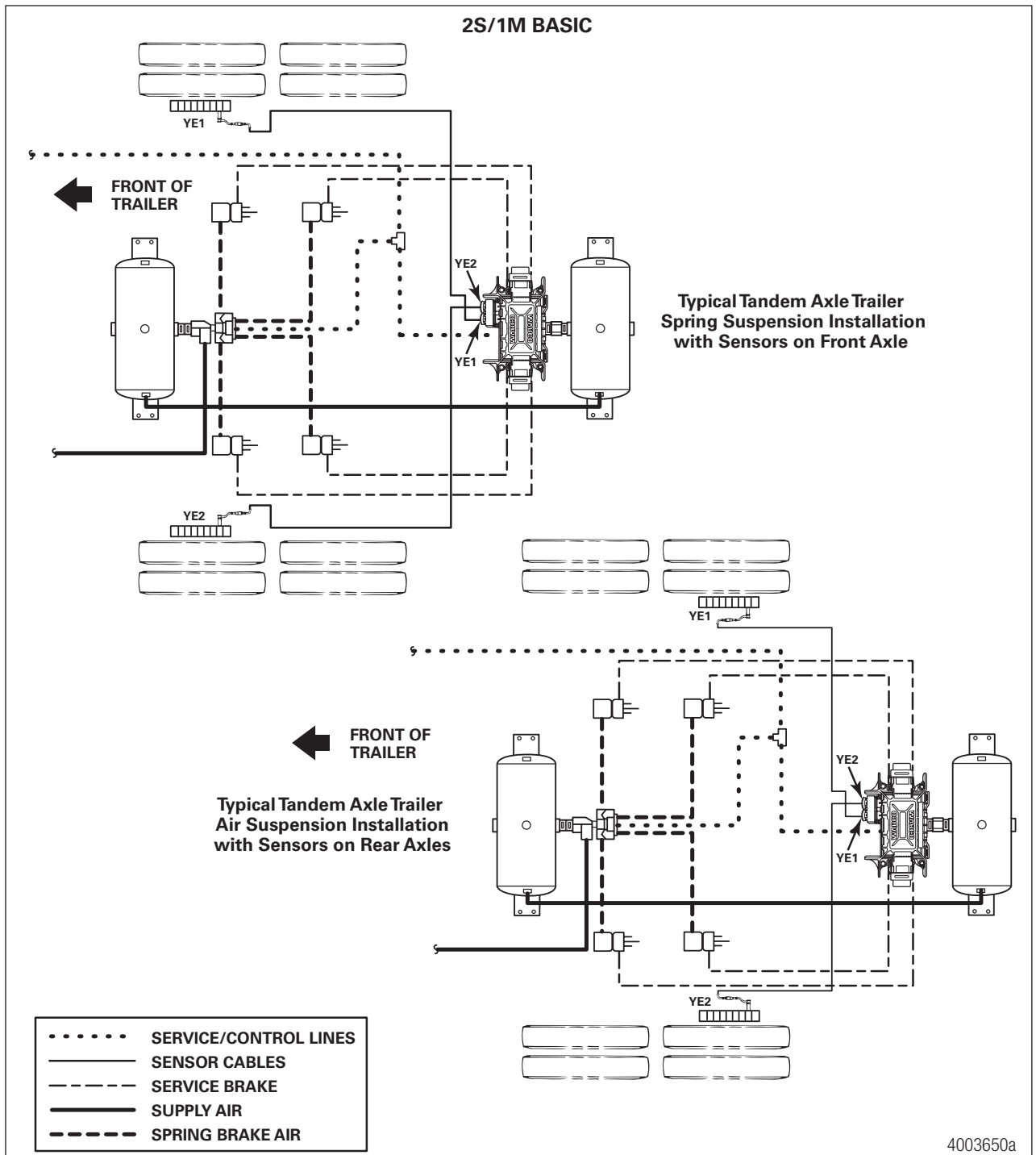

System Configurations

i WABCO recommends placing sensors on the axle that will provide the most braking performance. The suspension manufacturer can provide this information.

Fig. 5.2

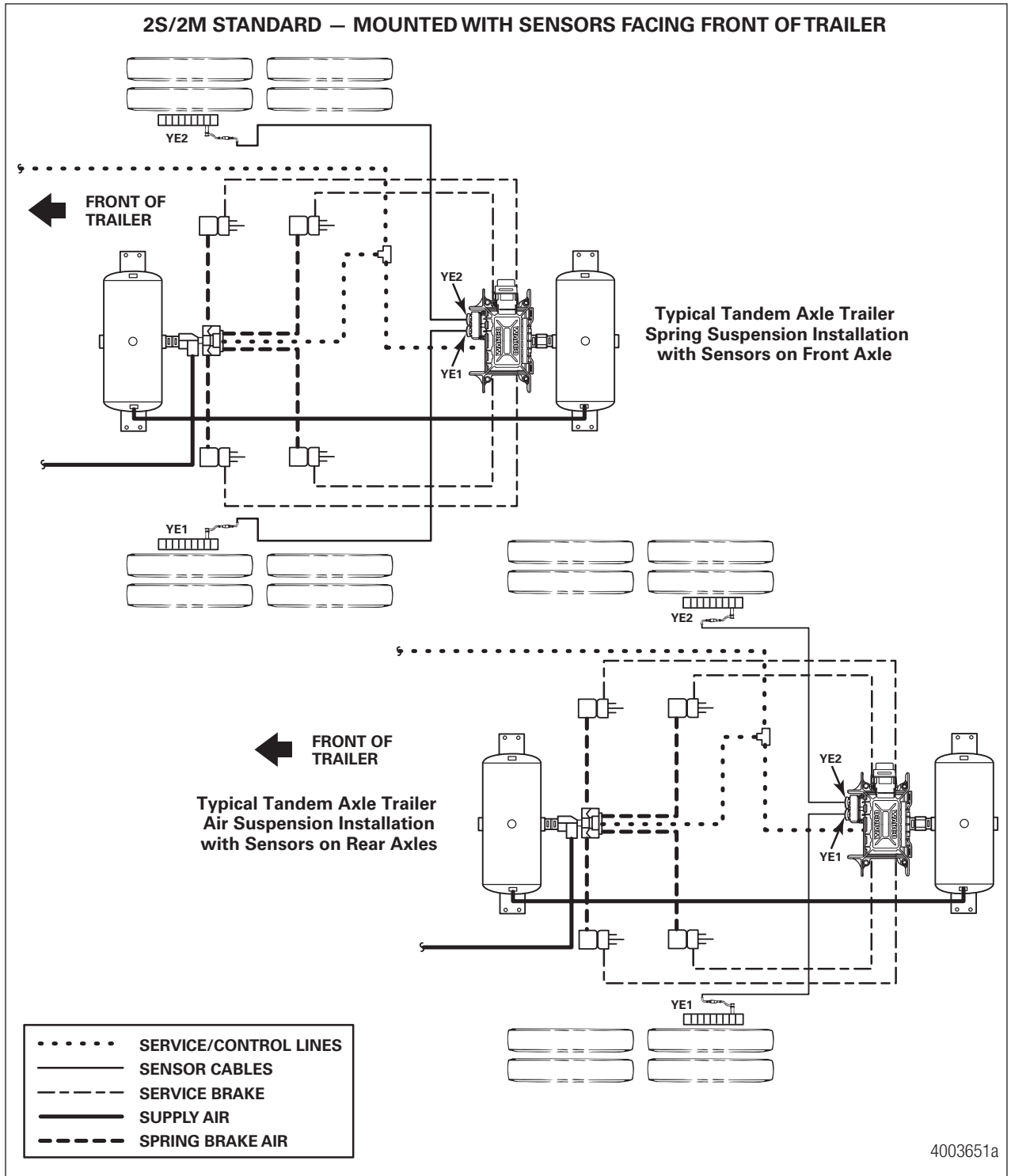

System Configurations

i WABCO recommends placing sensors on the axle that will provide the most braking performance. The suspension manufacturer can provide this information.

Fig. 5.3

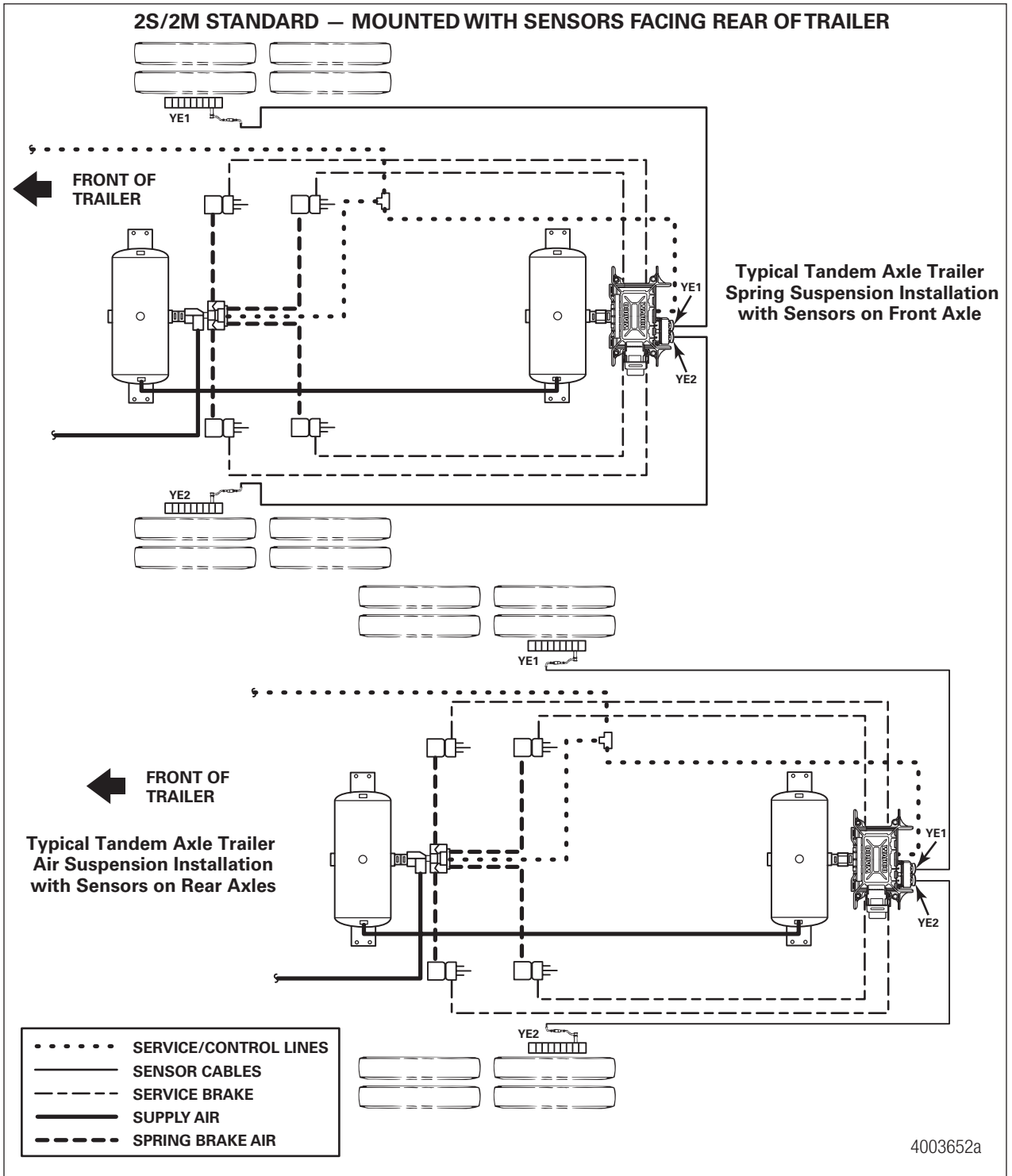

System Configurations

i When using a 4-sensor capable ABS ECU, but only using 2 sensors, make sure the sensors used are YE1 and BU1. If a sensor is plugged into the YE2 or BU2 port when powered up, the system will automatically configure to a 4-sensor system. To reconfigure an ECU to a 2-sensor configuration, TOOLBOX PLUS™ Software is required.

Fig. 5.4

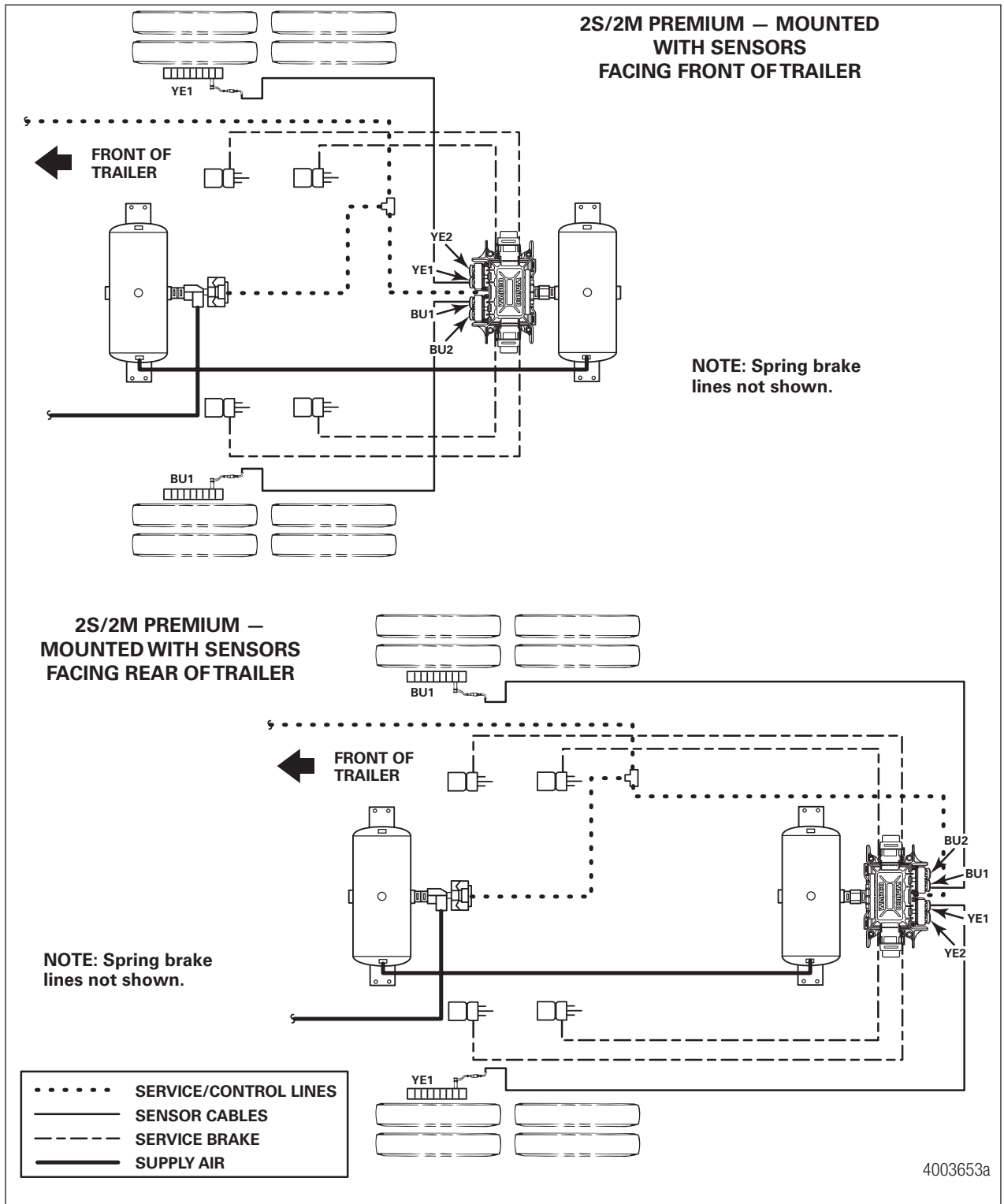

System Configurations

i WABCO recommends placing sensors on the axle that will provide the most braking performance. The suspension manufacturer can provide this information.

Fig. 5.5

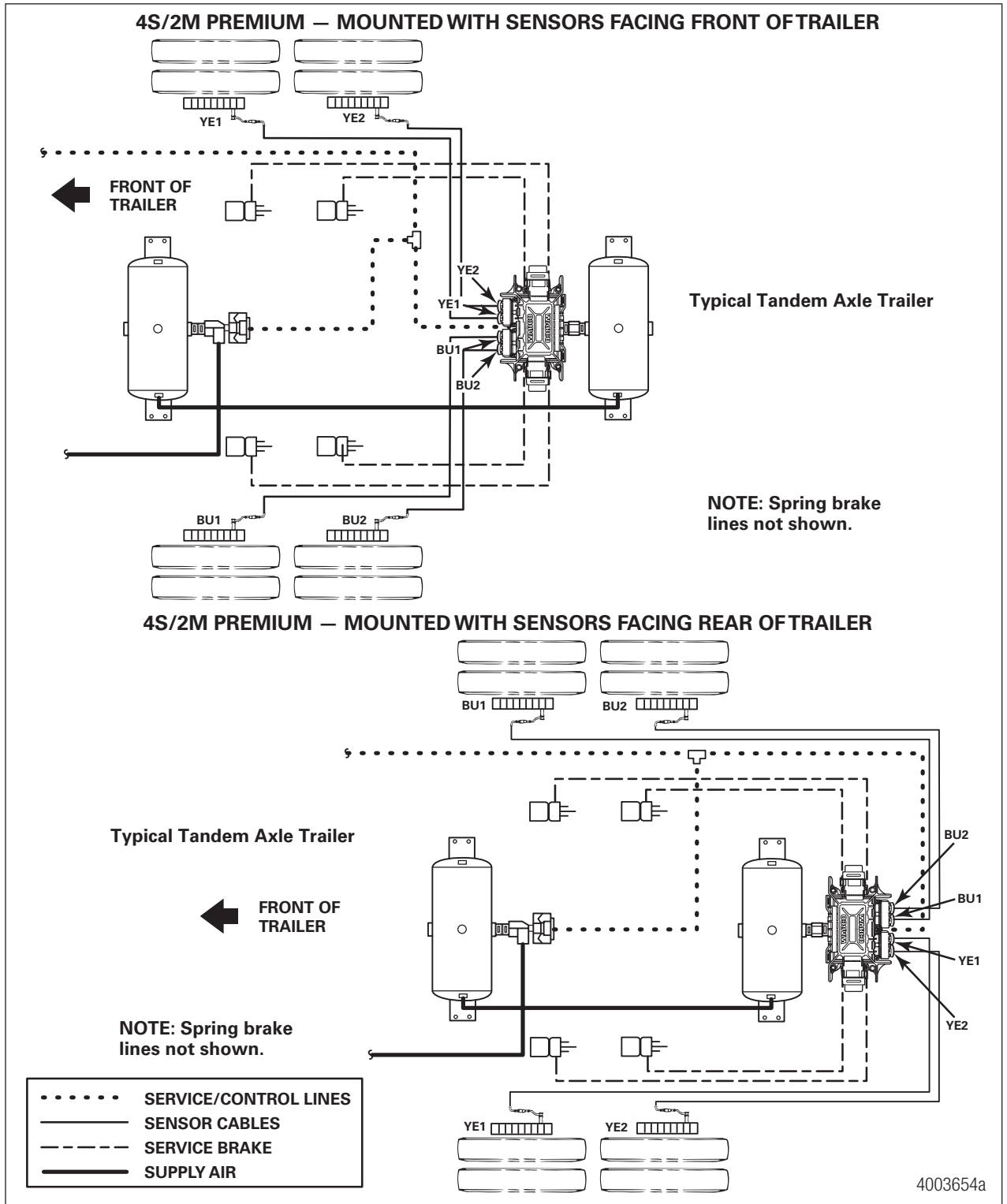

System Configurations

Fig. 5.6

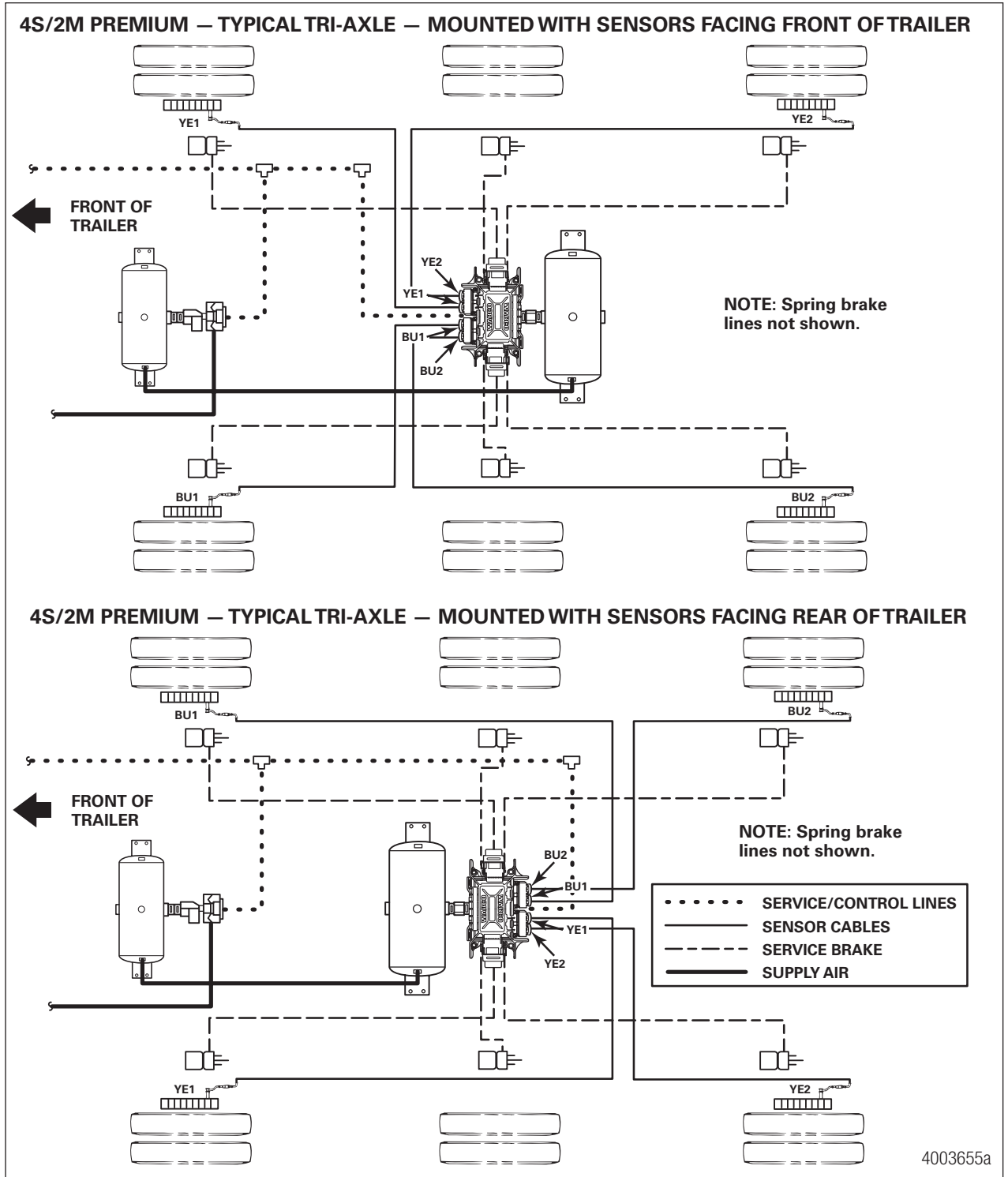

System Configurations

Fig. 5.7

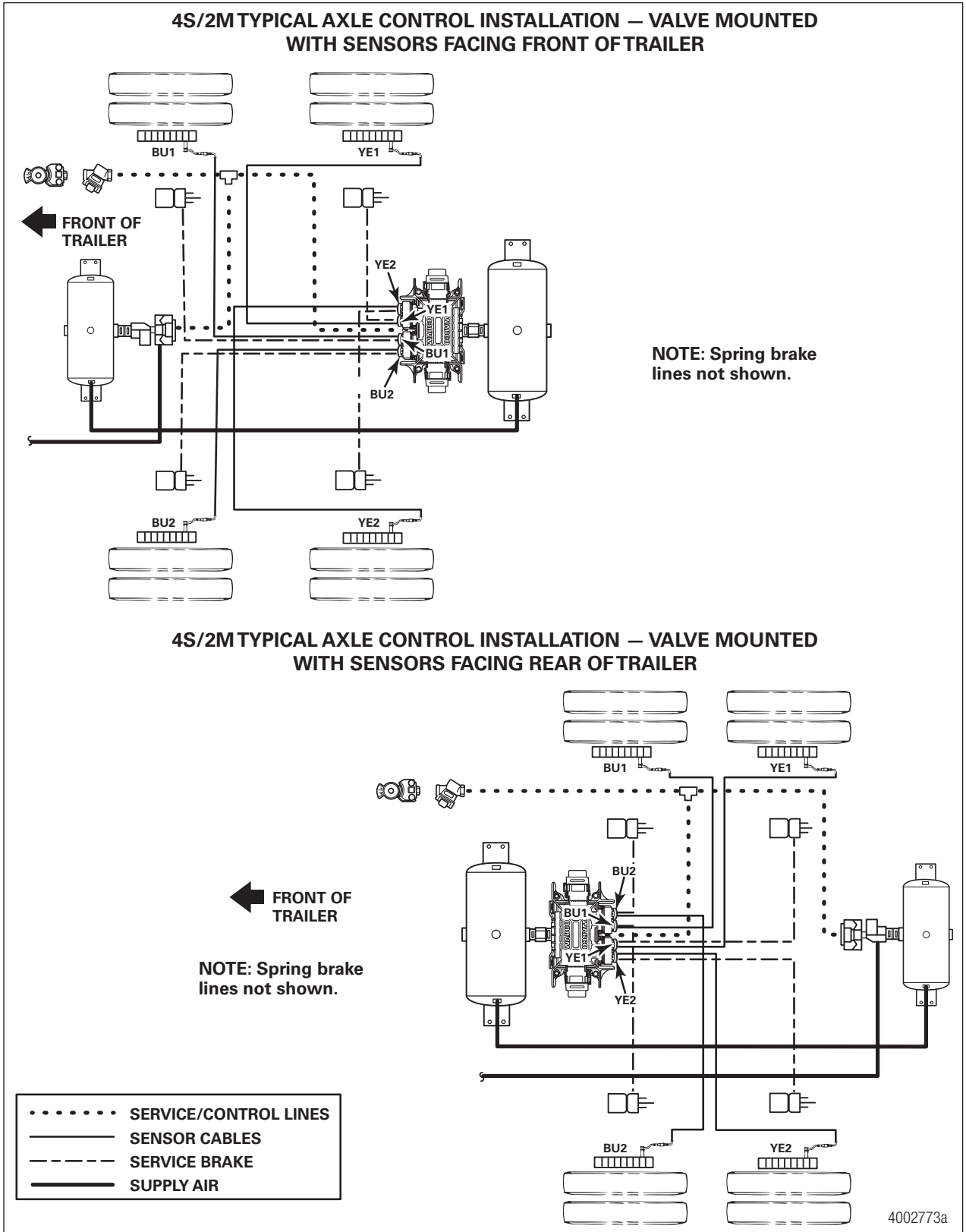

System Configurations

Fig. 5.8

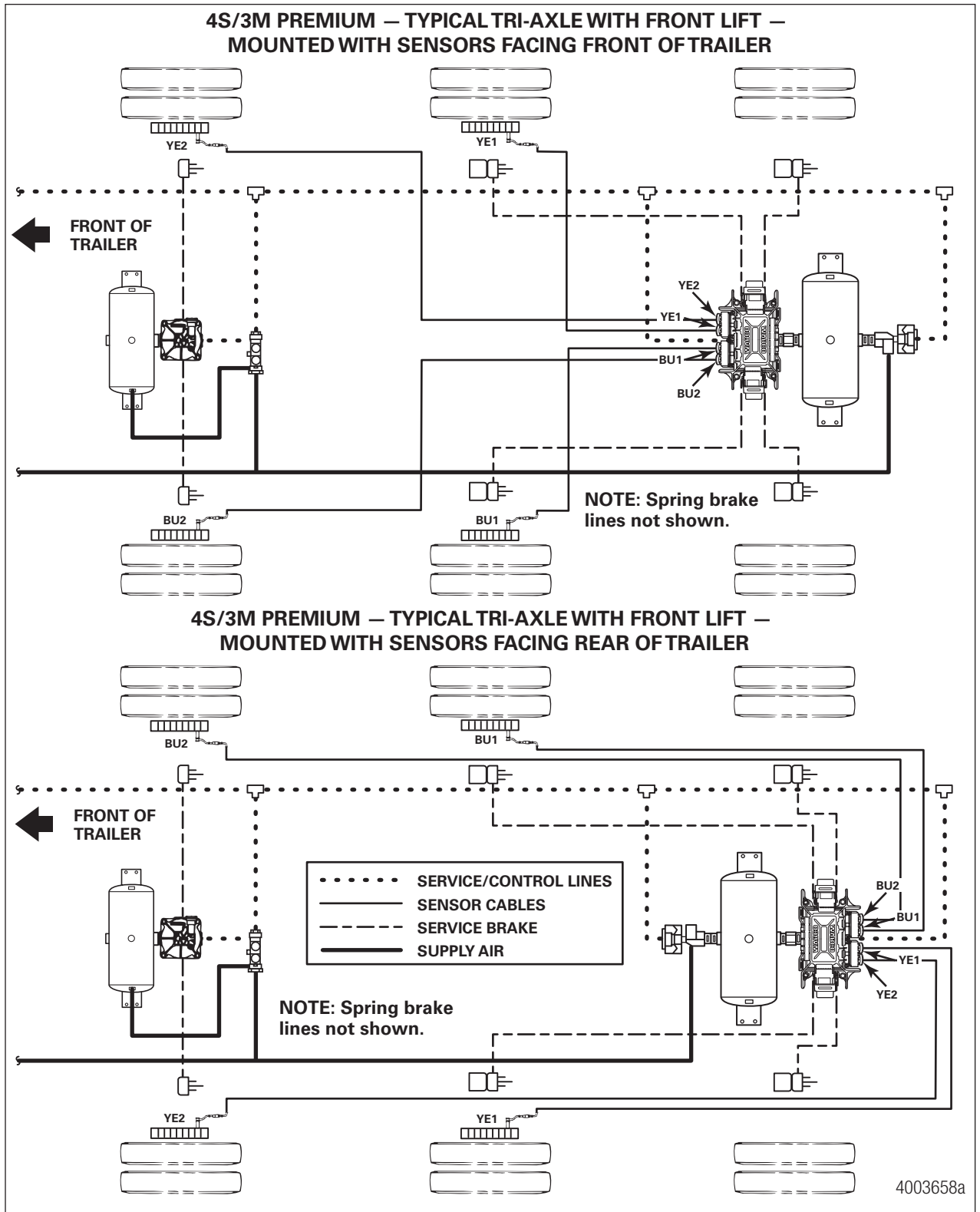

System Configurations

Fig. 5.9

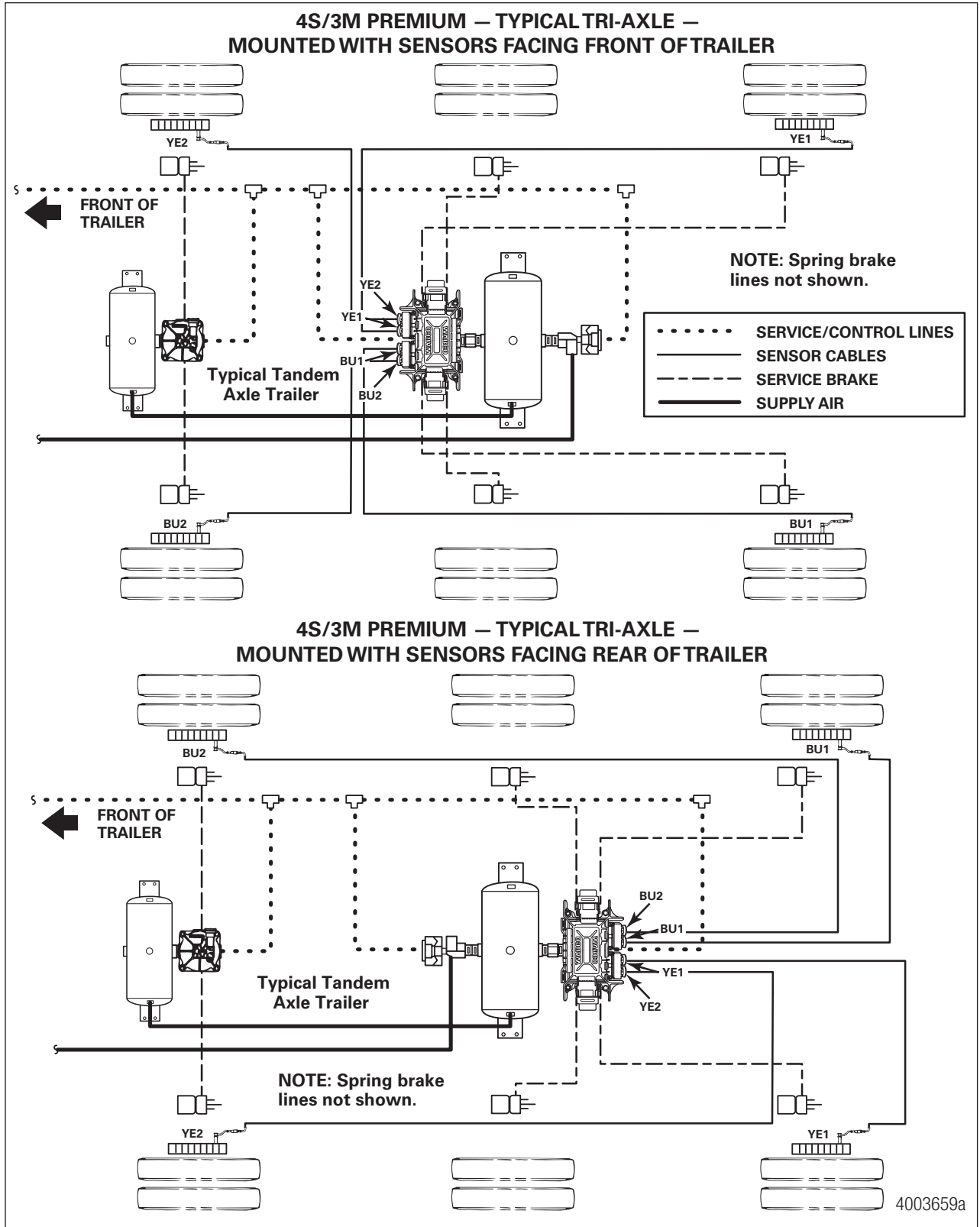

System Configurations

Fig. 5.10

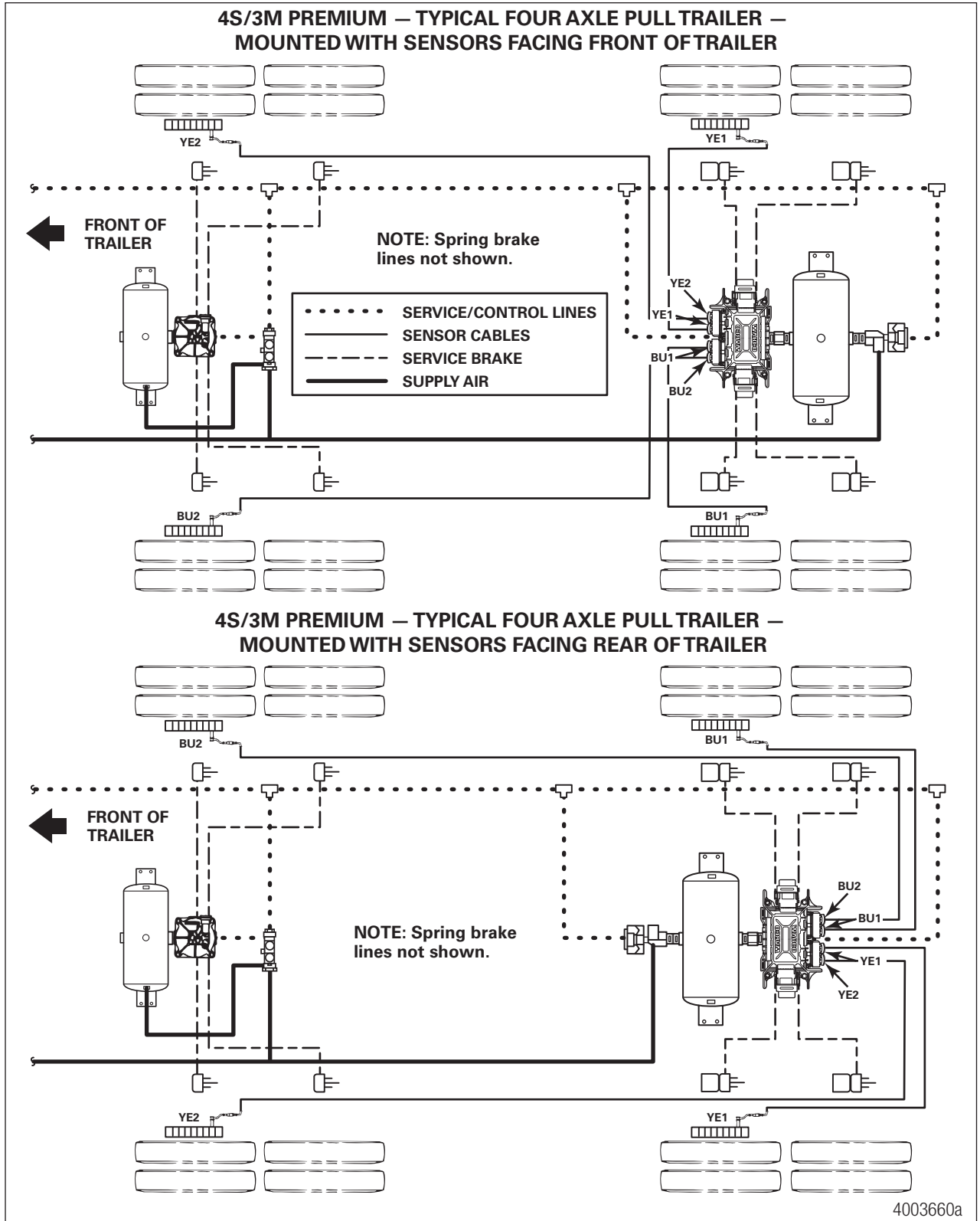

System Configurations

5.2 Power Cable Wiring Diagrams

Fig. 5.11

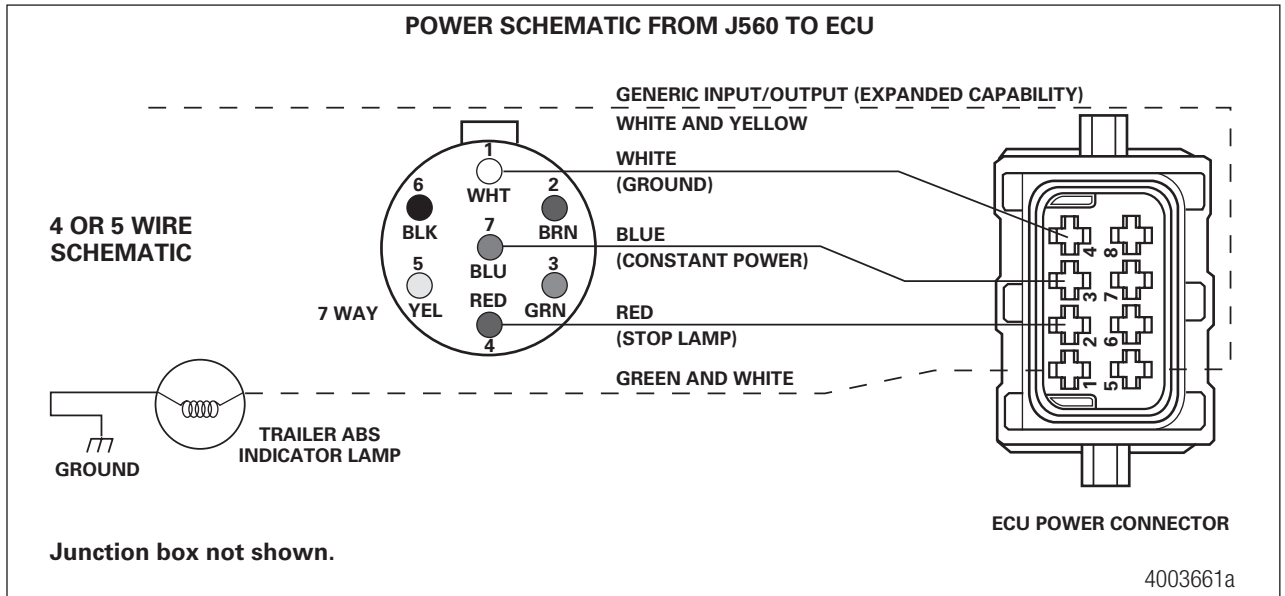
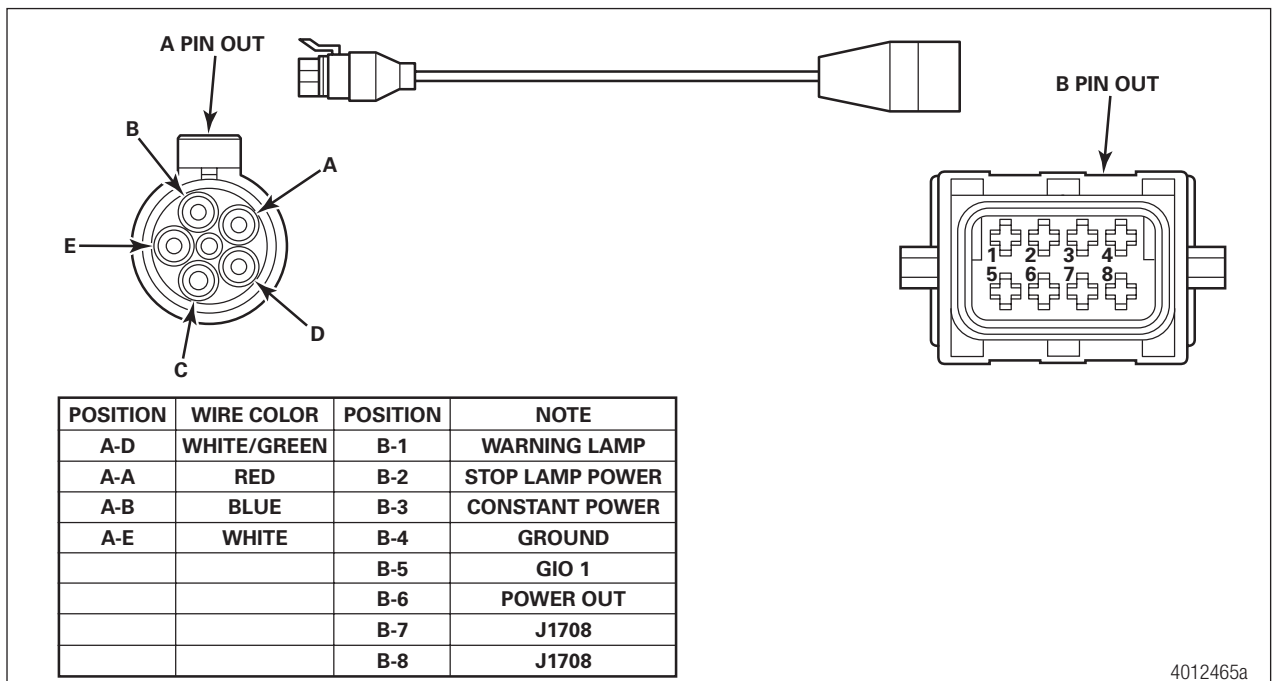
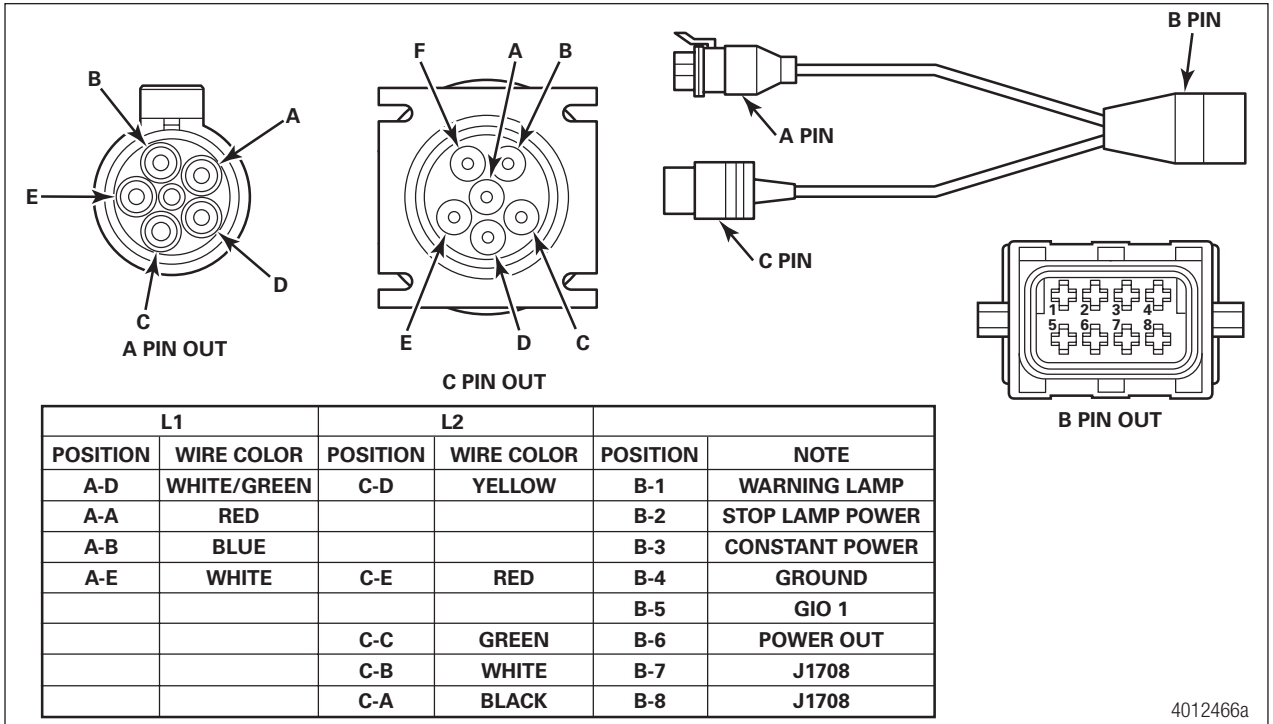

Fig. 5.12



System Configurations

Fig. 5.13



4012466a

Diagnostics

6 Diagnostics

Hazard Alert Messages

Read and observe all Warning and Caution hazard alert messages in this publication. They provide information that can help prevent serious personal injury, damage to components, or both.

⚠️ WARNING

To prevent serious eye injury, always wear safe eye protection when you perform vehicle maintenance or service.

⚠️ WARNING

The ABS is an electrical system. When you work on the ABS, take the same precautions that you must take with any electrical system to avoid serious personal injury. As with any electrical system, the danger of electrical shock or sparks exists that can ignite flammable substances. You must always disconnect the battery ground cable before working on the electrical system.

There are three methods used to get fault information from the ECU:

- TOOLBOX PLUS™ Software
- Pro-Link 9000
- Blink code diagnostics
 - Ignition power activation
 - Diagnostic tool

There is also a new diagnostic tool for checking PLC, the Heavy Duty Trailer Diagnostic adapter.

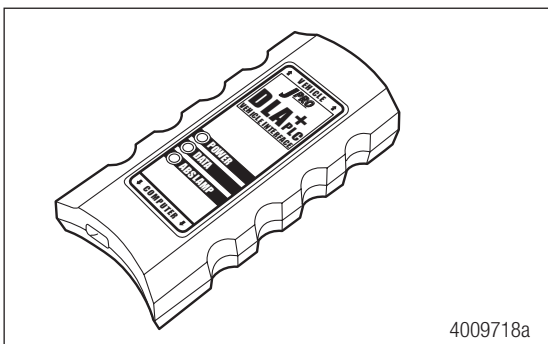

Available from jprofleetproducts.com.

6.1 Important PLC Information for Blink Code Diagnostics

Blink Code 17 indicates a PLC failure. If PLC does not seem to be operating correctly, but there is no Blink Code 17, the ECU is functioning correctly and does not need to be replaced; however, there could be a problem in the trailer's wiring harness. Check the wiring system and make the necessary repairs. If the problem persists, contact the customer service center for assistance.

Diagnostics

6.2 TOOLBOX PLUS™ SOFTWARE

TOOLBOX PLUS™ Software is a PC-based diagnostic program that can display fault codes, wheel speed data, test individual components, verify installation wiring and is required to perform signoff for the Enhanced Easy-Stop with PLC installation.

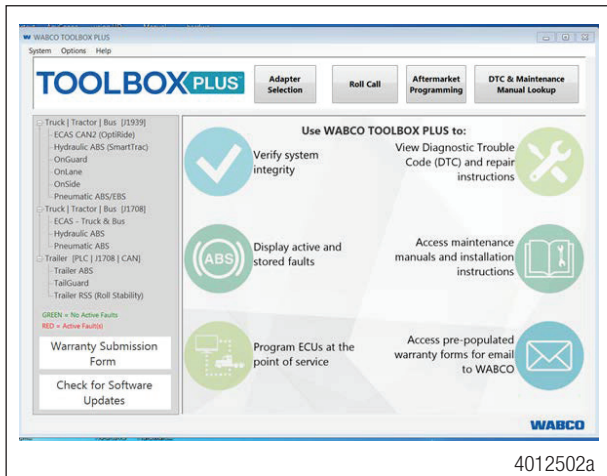

TOOLBOX PLUS™ Software is available for purchase via download 24 hours a day, seven days a week on wabco-auto.com. Version 12.2 (or higher) supports Enhanced Easy-Stop with PLC using Windows® XP or higher.

TOOLBOX PLUS™ Software is available for purchase via download at <https://wabco.snapon.com/>. TOOLBOX PLUS™ will work on PC/Laptop with Windows 7, 8, 10.

TOOLBOX PLUS™ Software has the following functions.

- Supports Enhanced Easy-Stop with PLC.
- Displays both constant and changing information from the ECU being tested.
- Displays both active and stored system faults, as well as the appropriate repair instructions.
- Activates system components to verify:
 - System integrity
 - Correct component operation
 - Installation wiring



A J1587/J1708 to RS232 or PLC to J1708 interface is required to run this software.

Diagnostics

6.3 TOOLBOX PLUS™ SOFTWARE SCREENS

Main Screen

This screen provides icon and pull-down menu task selections. It also provides information about the current state of the WABCO Enhanced Easy-Stop Trailer ABS. ECU information is read once from the ECU and does not change. Wheel speed, voltages, faults and information are read and updated continuously.

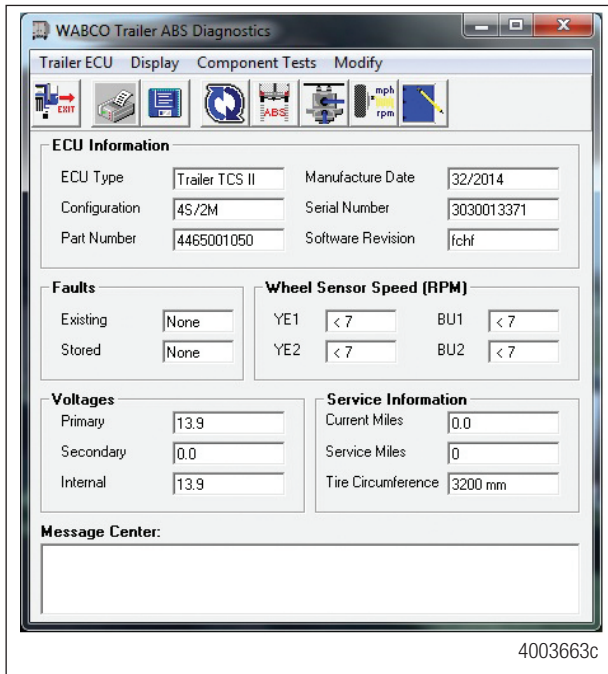

Tire Calibration

Tire calibration may be accessed from the Modify pull-down on the Main Screen.

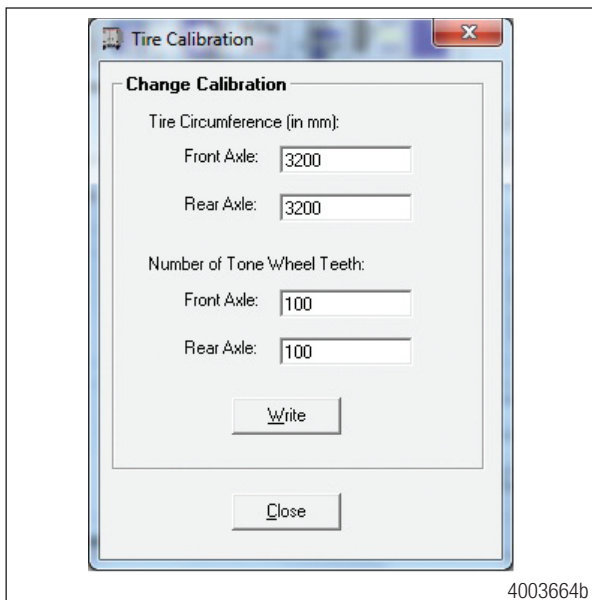

Diagnostics

The programmed number of millimeters for tire circumference is displayed on the Tire Calibration screen. The allowable range is dependent on the number of teeth on the tone ring. Use the tire manufacturer's recommended tire circumference in millimeters for this value. Enter the correct number of millimeters, select the appropriate tone ring, and press the Write button.

| Tone Ring Teeth | Tire Circumference (mm) |
|-----------------|-------------------------|
| 80 | 2048-3072 |
| 90 | 2304-3456 |
| 100 | 2560-3840 |

Service Information

Service Information may be accessed from the Modify pull-down on the Main Screen.

In the Service Information field, the ECU, working with a constant powered tractor, can act as a mileage counter. This field can also be used to set service intervals.

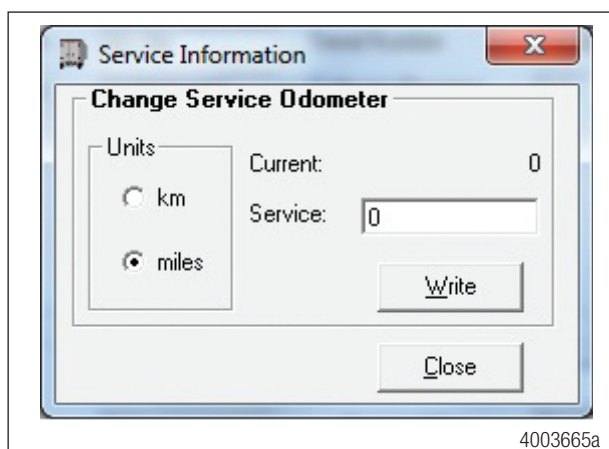

The mileage between scheduled maintenances is displayed on the Service Information screen in km or miles.

When the mileage displayed elapses, the Enhanced Easy-Stop Trailer ABS indicator lamp on the side of the trailer will flash eight times, whenever the ignition switch is turned on until this parameter is changed.

Select the appropriate mileage units for the service information service interval by clicking on the appropriate radio button.

Click in the Service field and key in the desired service interval. This is the distance to elapse beyond the current mileage displayed when the trailer ABS indicator light should flash and provide notification. Once the desired mileage interval has been input, click on the Write button. Click on the Close button to exit the function.

To disable the Service interval feature, change the mileage to 0 and click on the Write button. Click on the Close button to exit the function.

Diagnostics

Notebook

The notebook may be accessed from the Modify pull-down on the main screen.

The Service Information field of this screen is used to store and review information about a specific vehicle including TIO information.

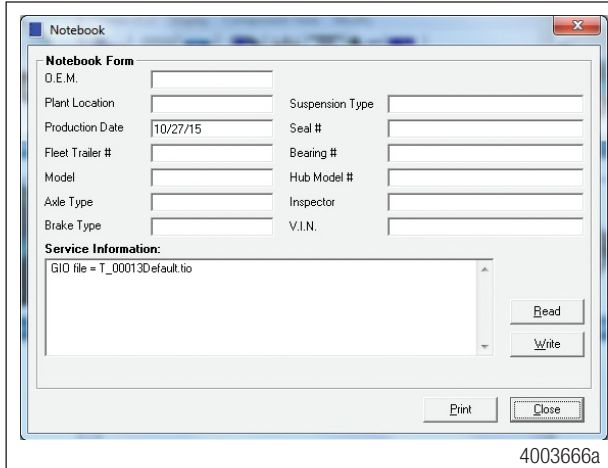

Sensor Test

The sensor test may be accessed from the Component Tests pull-down on the main screen.

The Sensor Test screen is used to determine the correct installation, wiring and functionality of the wheel speed sensors.

The screen display will provide maximum sensor RPM for installed sensors (unused sensor positions will be grayed out). Check the order field to verify sensors are installed in the correct location.

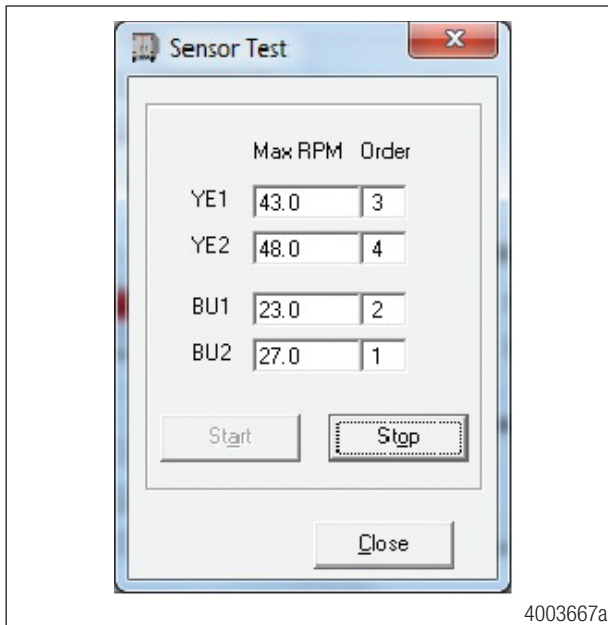

Diagnostics

Lift Axle Sensor Test

The Lift Axle Sensor test is used to determine the correct installation, wiring and functionality of the lift axle wheel sensors. The screen display will provide the maximum tested sensor RPM for the installed sensors. Visually check the order field to verify that sensors are installed in the correct location. Sensors YE2 and BU2 are always to be placed on the lift axle wheel ends. This prevents the warning lamp from coming on when the lift axle is in the raised position.

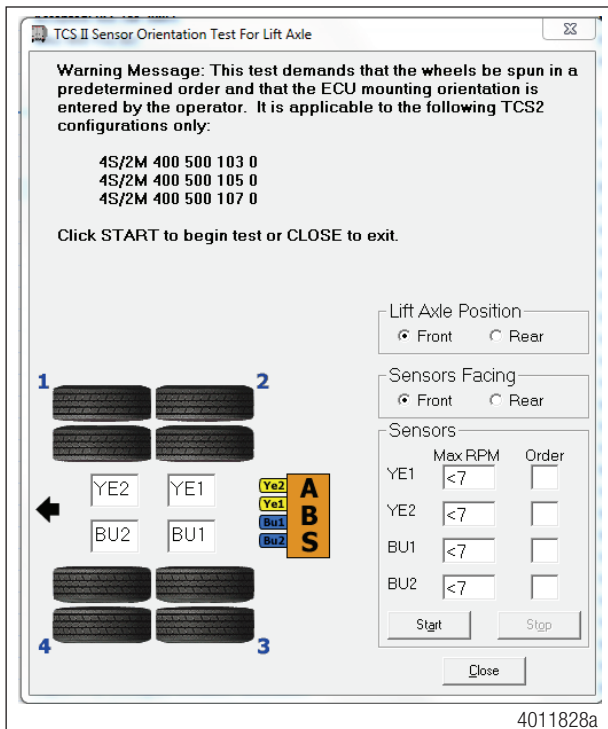

Diagnostics

Report Information

The Report Information screen allows the user to store information about a specific vehicle, including the Vehicle Identification Number (VIN) and Employee numbers.

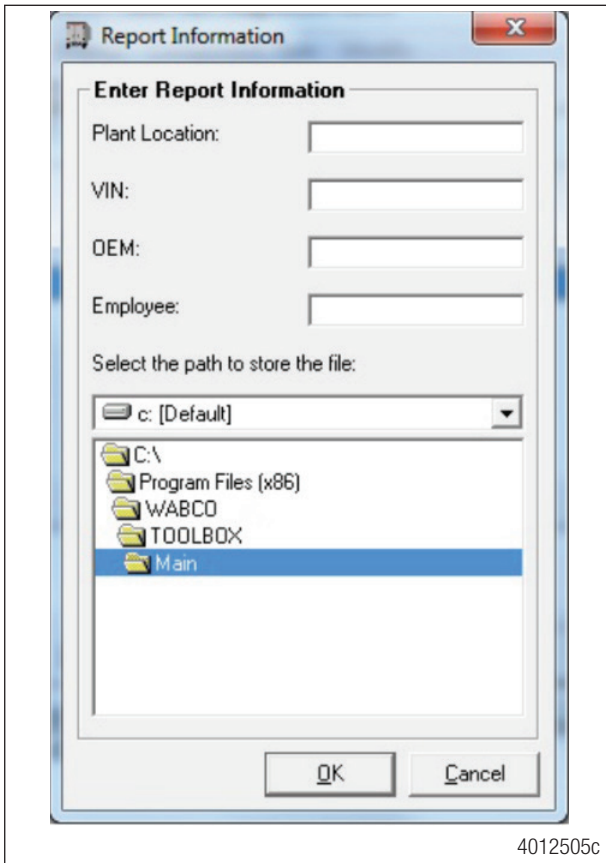

4012505c

Diagnostics

An example of a storable (or printable) report is displayed.

| WABCO ABS Fault Report | | | | | |
|----------------------------------|---|---------------|------------|------------|--------------|
| Date: | September 13, 2015 | | | | |
| Time: | 5:25 PM | | | | |
| Page: | 1 | | | | |
| VIN: | 12345678 | | | | |
| Employee Information: | KILEY | | | | |
| ABS System Configuration: | 4S/2M | | | | |
| ECU Revision: | V 3 2 2 | | | | |
| Part Number: | 446-108-000-1 | | | | |
| Serial Number: | 5 9 3 0 3 9 4 8 | | | | |
| Date of Manufacture: | 13/1999 | | | | |
| Current Miles: | 0.0 | | | | |
| Service Miles: | 0.0 | | | | |
| Tire Calibration: | 495.0 | | | | |
| Fault # | Description | Status | SID | FMI | Count |
| 1 | Ext. modulator BLUE open circuit detected | Active | 9 | 5 | 1 |
| 2 | Ext. modulator BLUE open circuit detected | Stored | 9 | 5 | 1 |
| Sensor Test Results: | | | | | |
| Sensor | Max RPM | Order | | | |
| YE1 | 40.0 | 1 | | | |
| YE2 | 59.0 | 2 | | | |
| BU1 | 50.0 | 3 | | | |
| BU2 | 38.0 | 4 | | | |
| Valve Tests Performed: | | | | | |
| Valve | Status (Tested / Not Tested / NA) | | | | |
| Yellow | Tested | | | | |
| Blue | Tested | | | | |
| Red | N/A | | | | |
| | | | | | 4003669b |

Save and Print

1. Click on the heading Trailer ECU and click Save. A window will appear asking for the VIN and Employee number.
2. Provide this information and close the window.
3. Go back to the heading Trailer ECU and click Print. You will be asked to input the VIN and Employee name or number.
4. Click Print.

Diagnostics

6.4 Initial Power-up Check

Whenever the trailer is initially powered up, the ABS light should come on for three seconds and the valves should click during self-tests. If the ABS light comes on again during the same ignition cycle, it would indicate an issue. If the valves do not click during the self-test, power and ground checks need to be performed at the ECU power connector. Also in this case, ensure all sensor cables are seated correctly at the ECU.

6.5 Power and Ground Checks

If the valve is not self-testing (no clicking from the valve), perform the following power and ground checks at the ABS ECU power connector shown.

1. Check the power cable connector at the ECU and verify that the lock tab is there and the connector is secure.
2. Disconnect the cable from the ECU and check for any signs of moisture, corrosion, spread or damaged pins.
3. Check with the power on voltage from pin 3 (constant power) to chassis ground for 9 to 14 volts.
 - If power shows between 9 to 14 volts, go to step 4.
 - If power is less or more than 9 to 14 volts, check the wiring for damage and review with the OEM.
4. With power on, check voltage from pin 2 (stop light power) to chassis ground with the brake pedal depressed to chassis ground for 9 to 14 volts.
 - If power shows between 9 to 14 volts, go to step 5.
 - If power is less or more than 9 to 14 volts, check wiring for damage and review with the OEM.
5. With power off, check the resistance from pin 4 on the ECU power connector to chassis ground for less than 10 ohm.
 - If the resistance is less than 10 ohm, go to step 6.
 - If the resistance is higher than 10 ohm, check wiring for damage and review with the OEM.
6. With the power on, check constant power circuit. Perform a load lamp test across pins 3 to 4 and verify a bright light.
 - If the light is bright, go to step 8.
 - If the light does not light up brightly, diagnose and review the wiring with the OEM.
7. With the power on, check the stoplight circuit. Perform a load lamp test across pins 2 to 4 with the brakes applied and verify a bright light.
 - If the light is bright, go to step 8.
 - If the light does not light up brightly, diagnose and review the wiring with the OEM.
8. If no problems are found with the harness checks may indicate the ECU/valve assembly has failed.

Diagnostics

6.6 Blink Code Diagnostics

The WABCO Enhanced Easy-Stop Trailer ABS ECU detects any electrical fault in the trailer ABS. Each of the faults has a code. When a fault occurs, the ECU stores the code for that fault in the memory.

There are two kinds of faults: active and stored. Active faults are those currently existing in the system, such as a broken wire. Stored faults are faults that have occurred but do not presently exist. Active faults can be cleared only after repairs are completed. Stored faults can only be diagnosed with TOOLBOX PLUS™ Software or the Pro-Link 9000.

The ECU signals a malfunction by lighting both the internal and external indicator lamp when a fault exists. The external ABS indicator lamp is usually mounted on the left rear of the trailer, near the rear wheels.

There are two ways to obtain blink codes:

- Ignition Power Activation (recommended method)
- Diagnostic Tool



In previous versions of Easy-Stop, the blink code tool and the ABS indicator lamp would flash the blink code at the same time. With Enhanced Easy-Stop, this does not happen. The codes are displayed one blink at a time, first on the trailer ABS lamp, then on the blink code tool, as illustrated.

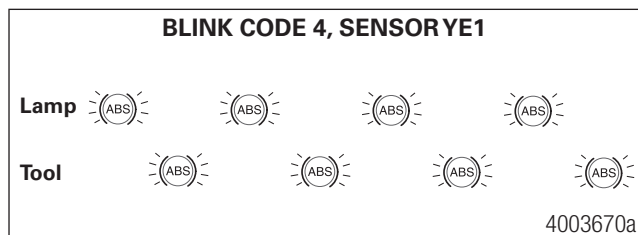

Although the ECU can store multiple faults in its memory, it only displays one fault at a time. This is why it is important to recheck the blink codes after repairing a fault. If there are additional codes in the memory, they only blink after you have repaired the first fault.

Stored faults, clear all and end of line test modes are available with the TOOLBOX PLUS™ Software or the Pro-Link 9000.

6.6.1 Ignition Power Activation

Ignition Power Activation is the process of using the vehicle's ignition switch (or interrupting the power on the blue wire by some other means) to display blink codes on the trailer ABS indicator lamp located on the side of the trailer. This method is for constant power vehicles only.

To obtain blink codes using ignition power activation, perform the following procedure:

1. Turn the ignition switch on for no longer than 5 seconds. The ABS indicator lamp will be on.
2. Turn the ignition switch off. The ABS indicator lamp will go out.
3. Turn the ignition switch on. The ABS indicator lamp will then come on, then go out.
4. The blink code will be displayed three times by the ABS indicator lamp on the trailer.



For ignition power activation, power is provided by the ignition switch.

Diagnostics

Blink Code Table

| Blink Code | Problem Area | Action |
|------------|--|---|
| 3 | Sensor BU1 | Determine sensor location. Check sensor installation. Perform necessary repairs. |
| 4 | Sensor YE1 | Determine sensor location. Check sensor installation. Perform necessary repairs. |
| 5 | Sensor BU2 | Determine sensor location. Check sensor installation. Make necessary repairs. |
| 6 | Sensor YE2 | Determine sensor location. Check sensor installation. Perform necessary repairs. |
| 7 | External ABS modulator valve | Verify correct electrical installation. Check power supply. Make necessary corrections. |
| 8 | Service interval notification | Indication that designated service mileage has elapsed. |
| 9 | Internal modulator failure, inlet valve #2 | Verify correct installation. If code continues, contact WABCO for assistance. |
| 10 | Internal modulator failure, inlet valve #1 | Verify correct installation. If code continues, contact WABCO for assistance. |
| 11 | Internal modulator failure, outlet valve | Verify correct installation. If code continues, contact WABCO for assistance. |
| 14 | Power Supply | Verify correct electrical installation. Check power supply. Make necessary corrections. |
| 15 | ECU Failure | Verify correct installation. If code continues, contact WABCO for assistance. |
| 16 | SAE J1708 Failure | Internal failure, contact WABCO. |
| 17 | SAE J2497 (PLC) Failure | Internal failure, contact WABCO. |
| 18 | Generic I/O Failure | Internal failure, contact WABCO. |

6.6.2 Diagnostic Tool (Blink Code Check)

The red dust cap on the diagnostic tool protects the tool during shipping. The tool and the LED are independently sealed against contamination.

The SAE J1587 connector must be protected from contamination when the diagnostic tool is not installed. Reinstall the gray cap when the connector is not in use.

Use the following procedures to install the diagnostic tool in the SAE J1587 connector.

1. Remove the gray protective cap from the J1587 connector.
 - Turn the cap counterclockwise.
 - Pull off the cap.
2. Align the notches on the tool with the notches on the connector.
3. Insert the tool firmly in the connector.

Diagnostics

4. Firmly turn the gray ring of the tool clockwise to secure it in place.

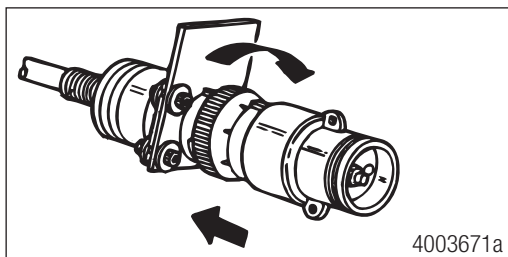

5. After removing the diagnostic tool, replace the gray protective cap.
6. Make sure the vehicle is stationary:
 - Emergency brake ON
 - Wheels correctly chocked
7. Provide 12 volts DC power (9.5 to 14 volts is acceptable range) to the ECU/Valve Assembly.
8. Check the ABS indicator lamp on the trailer. If:
 - The indicator lamp comes ON briefly, then goes OFF: There is no fault in system.
 - The indicator lamp comes ON and stays ON: There is an existing fault. Go to Step 9.
9. Press the blink code switch **once** for **one second** and release the switch.
10. When there is an existing fault: The ABS indicator lamp will flash between three and eighteen times to identify the existing fault.
11. When there are existing faults: You must repair existing faults.
12. After you identify an existing fault, turn the power to the ECU **OFF**. Repair the fault. Turn the power to the ECU back **ON**.
13. Repeat Step 9. If there are no other existing faults in the system, the ABS indicator lamp will come **ON**, go **OFF** and remain **OFF**.
14. If you have just repaired a sensor gap fault, the ECU is “waiting” to see a 4-mph signal on sensed wheels. Until this 4 mph is sensed by the ECU, the ABS indicator lamp on the trailer will remain **ON**.

6.6.3 MPSI Pro-Link 9000 Diagnostic Tool

The MPSI Pro-Link 9000 diagnostic tool can test for existing and stored faults, read and clear fault codes, and test components, for WABCO tractor and trailer ABS.



A J 38500-60A Deutsch cable is also required.

Diagnostics

Diagnostic Table

| SID | FMI | Suspect Component and Location | Fault Description | Cause | Repair Information |
|-----|-----|--------------------------------|------------------------|--|--|
| 3 | 1 | BU1 Sensor | Air Gap | Sensor air gap is too large; sensor output voltage is too low but is high enough to be read by ECU. | <ul style="list-style-type: none"> - Adjust wheel sensor to touch tone ring. - Check condition of ABS sensor head. - Check for loose wheel bearings or excessive hub runout. - Check mounting of ABS tone ring and condition of teeth. - Check condition and retention of ABS sensor spring clip. - Check ABS sensor cable integrity. - Turn the wheel at half a revolution per second and verify 0.2 AC volt sensor output voltage. |
| 3 | 2 | BU1 Sensor | Wheel Speed Difference | System has detected a significant difference in the proportion of tire diameter to number of tone ring teeth between wheel ends. | <ul style="list-style-type: none"> - Check for tire size mismatch. - Check for correct number of tone ring teeth. |
| 3 | 3 | BU1 Sensor | Shorted to UBATT | Continuity between the sensor connection and battery voltage (short circuit) is detected. | <ul style="list-style-type: none"> - Verify 900-2000 ohms resistance through sensor circuit. - Verify no DC voltage through sensor cable when key is ON. - Check for corroded or damaged wiring between ECU and ABS wheel speed sensor. |
| 3 | 4 | BU1 Sensor | Shorted to Ground | Continuity between the sensor connection and ground (short circuit) is detected. | <ul style="list-style-type: none"> - Verify 900-2000 ohms resistance through sensor circuit. - Check for continuity between ABS sensor connection and ground. - Check for corroded or damaged wiring between ECU and ABS wheel speed sensor. |
| 3 | 5 | BU1 Sensor | Open Circuit | An open circuit has been detected, i.e. ECU detects a disconnected wheel speed sensor. | <ul style="list-style-type: none"> - Check sensor, sensor cable and connectors to verify no loose or damaged connection. - Verify 900-2000 ohms resistance through sensor circuit. - Check for corroded or damaged wiring between the ECU and the ABS wheel speed sensor. - Swap sensor cable in question with adjacent sensor cable at the ECU. If the fault code stays in the same location, replace ECU. If the fault code changes locations, replace the suspect sensor. |
| 3 | 6 | BU1 Sensor | Short Circuit | Continuity interruption between the sensor connections (short circuit) has been detected. | <ul style="list-style-type: none"> - Check sensor, sensor cable and connectors to verify no loose or damaged connection. - Check for corroded or damaged wiring between the ECU and the ABS wheel speed sensor. - Check for corrosion or discoloration at ECU sensor pins and/or connector. - Visually inspect sensor extension female connector to ensure it is not out of round or spread resulting in intermittent contact with the ECU sensor pins. - Verify 900-2000 ohms resistance through sensor circuit. - Swap sensor in question with adjacent sensor at the ECU. If the fault code stays in the same location, replace ECU. If the fault code changes locations, replace the suspect sensor. |

Diagnostics

| SID | FMI | Suspect Component and Location | Fault Description | Cause | Repair Information |
|-----|-----|--------------------------------|---------------------------------|---|---|
| 3 | 7 | BU1 Sensor | Tone Ring Damaged | Wheel speed signal drops out periodically at speeds higher than 6 mph. | <ul style="list-style-type: none"> - Check for damaged or missing teeth on tone ring. - Verify tone ring is not corroded or with contamination. - Check for loose wheel bearings or excessive hub runout. - Swap sensor cable in question with adjacent sensor cable at the ECU. If the fault code stays in the same location, replace ECU. If the fault code changes locations, replace the suspect sensor. |
| 3 | 8 | BU1 Sensor | Excessive Slip | Wheel slip over 16 seconds continuously has been detected. | <ul style="list-style-type: none"> - Check tone ring. - Adjust wheel sensor to touch tone ring. - Check sensor gap. - Inspect tone ring for damage. - Check for loose wheel bearings or excessive hub runout. |
| 3 | 9 | BU1 Sensor | No Speed | A temporary loss of the ABS wheel speed signal has been detected. | <ul style="list-style-type: none"> - Adjust wheel speed sensor until it touches the tone ring. - Check for loose wheel bearings or excessive hub runout. - Check sensor wiring, cable routing and connectors for intermittent contact. - Check condition of ABS sensor head. - Check mounting of tone ring and condition of teeth. - Check for corroded or damaged wiring between the ECU and the ABS wheel speed sensor. - Turn the wheel at half a revolution per second and verify 0.2 AC volt sensor output voltage. |
| 3 | 10 | BU1 Sensor | Speed Jump Upwards or Downwards | Wheel speed difference. | <ul style="list-style-type: none"> - Adjust wheel speed sensor until it touches the tone ring. - Check for loose wheel bearings or excessive hub runout. - Check sensor wiring, cable routing and connectors for intermittent contact. - Check condition of ABS sensor head. - Check mounting of tone ring and condition of teeth. - Check condition and retention of ABS sensor spring clip. - Check for corroded or damaged wiring between the ECU and the ABS wheel speed sensor. - Turn the wheel at half a revolution per second and verify 0.2 AC volt sensor output voltage. |
| 3 | 11 | BU1 Sensor | Abnormal Speed (Chatter) | Brake drag or chatter has been detected. Abnormal vibrations detected which affect sensor signal. | <ul style="list-style-type: none"> - Check for loose wheel bearings or excessive hub runout. - Check sensor wiring and connectors for intermittent contact. - Check mounting of tone ring and condition of teeth. - Check condition and retention of ABS sensor spring clip as well as the mounting block. - Check for corroded or damaged wiring between the ECU and the ABS wheel speed sensor. - Turn the wheel at half a revolution per second and verify 0.2 AC volt sensor output voltage. |

Diagnostics

| SID | FMI | Suspect Component and Location | Fault Description | Cause | Repair Information |
|-----|-----|--------------------------------|----------------------------|---|---|
| 3 | 12 | BU1 Sensor | Software Interrupt Failure | A non-plausible sensor frequency has been measured. | <ul style="list-style-type: none"> - Check sensor wiring and connectors for intermittent contact. - Check if brake at this location is operating correctly, i.e., potentially dragging. - Check for corroded or damaged wiring between the ECU and the ABS wheel speed sensor. |
| 3 | 13 | BU1 Sensor | Wheel Speed Oscillating | Tone ring signal irregular. | <ul style="list-style-type: none"> - Check for loose wheel bearings or excessive hub runout. - Check sensor wiring and connectors for intermittent contact. - Check mounting of tone ring and condition of teeth. - If tone ring and sensor block are not aligned correctly oscillation may occur. Small dimensional deviations can result in this failure code. Issue occurs shortly after going into service and after driving. - Check condition and retention of ABS sensor spring clip as well as the mounting block. - Check for corroded or damaged wiring between the ECU and the ABS wheel speed sensor. - Turn the wheel at half a revolution per second and verify 0.2 AC volt sensor output voltage. |
| 4 | 1 | YE1 Sensor | Air Gap | Sensor air gap is too large; sensor output voltage is too low but is high enough to be read by ECU. | <ul style="list-style-type: none"> - Adjust wheel sensor to touch tone ring. - Check condition of ABS sensor head. - Check for loose wheel bearings or excessive hub runout. - Check mounting of ABS tone ring and condition of teeth. - Check condition and retention of ABS sensor spring clip. - Turn the wheel at half a revolution per second and verify 0.2 AC volt sensor output voltage. |
| 4 | 2 | YE1 Sensor | Wheel Speed Difference | System has detected a significant difference in the proportion (6%) of tire diameter to number of tone ring teeth between wheel ends. | <ul style="list-style-type: none"> - Check for tire size mismatch. - Check for correct number of tone ring teeth. |
| 4 | 3 | YE1 Sensor | Shorted to UBATT | Continuity between the sensor connection and battery voltage (short circuit) is detected. | <ul style="list-style-type: none"> - Verify 900-2000 ohms resistance through sensor circuit. - Verify no DC voltage through sensor circuit Key ON. - Check for corroded or damaged wiring between the ECU and the ABS wheel speed sensor. |
| 4 | 4 | YE1 Sensor | Shorted to Ground | Continuity between the sensor connection and ground (short circuit) is detected. | <ul style="list-style-type: none"> - Check sensor, sensor cable and connectors to verify no loose or damaged connection. - Verify 900-2000 ohms resistance through sensor circuit. - Check for corroded or damaged wiring between the ECU and the ABS wheel speed sensor. - Swap sensor cable in question with adjacent sensor cable at the ECU. If the fault code stays in the same location, replace ECU. If the fault code changes locations, replace the suspect sensor. |

Diagnostics

| SID | FMI | Suspect Component and Location | Fault Description | Cause | Repair Information |
|-----|-----|--------------------------------|---------------------------------|---|--|
| 4 | 10 | YE1 Sensor | Speed Jump Upwards or Downwards | Wheel speed difference. | <ul style="list-style-type: none"> - Adjust wheel speed sensor until it touches the tone ring. - Check for loose wheel bearings or excessive hub runout. - Check sensor wiring, cable routing and connectors for intermittent contact. - Check condition of ABS sensor head. - Check mounting of tone ring and condition of teeth. - Check condition and retention of ABS sensor spring clip. - Check for corroded or damaged wiring between the ECU and the ABS wheel speed sensor. - Turn the wheel at half a revolution per second and verify 0.2 AC volt sensor output voltage. |
| 4 | 11 | YE1 Sensor | Abnormal Speed (Chatter) | Brake drag or chatter has been detected. Abnormal vibrations detected which affect sensor signal. | <ul style="list-style-type: none"> - Check for loose wheel bearings or excessive hub runout. - Check sensor wiring and connectors for intermittent contact. - Check mounting of tone ring and condition of teeth. - Check condition and retention of ABS sensor spring clip as well as the mounting block. - Check for corroded or damaged wiring between the ECU and the ABS wheel speed sensor. - Turn the wheel at half a revolution per second and verify 0.2 AC volt sensor output voltage. |
| 4 | 12 | YE1 Sensor | Software Interrupt Failure | A non-plausible sensor frequency has been measured. | <ul style="list-style-type: none"> - Check sensor wiring and connectors for intermittent contact. - Check if brake at this location is operating correctly, i.e., potentially dragging. - Check for corroded or damaged wiring between the ECU and the ABS wheel speed sensor. |
| 4 | 13 | YE1 Sensor | Wheel Speed Oscillating | Tone ring signal irregular. | <ul style="list-style-type: none"> - Check for loose wheel bearings or excessive hub runout. - Check sensor wiring and connectors for intermittent contact. - Check mounting of tone ring and condition of teeth. - If tone ring and sensor block are not aligned correctly, oscillation may occur. Small dimensional deviations can result in this failure code. Issue occurs shortly after going into service and after driving. - Check condition and retention of ABS sensor spring clip as well as the mounting block. - Check for corroded or damaged wiring between the ECU and the ABS wheel speed sensor. - Turn the wheel at half a revolution per second and verify 0.2 AC volt sensor output voltage. |

Diagnostics

| SID | FMI | Suspect Component and Location | Fault Description | Cause | Repair Information |
|-----|-----|--------------------------------|------------------------|---|--|
| 5 | 1 | BU2 Sensor | Air Gap | Sensor air gap is too large; sensor output voltage is too low but is high enough to be read by ECU. | <ul style="list-style-type: none"> - Adjust wheel sensor to touch tone ring. - Check condition of ABS sensor head. - Check for loose wheel bearings or excessive hub runout. - Check mounting of ABS tone ring and condition of teeth. - Check condition and retention of ABS sensor spring clip. - Check ABS sensor cable integrity. - Turn the wheel at half a revolution per second and verify 0.2 AC volt sensor output voltage. |
| 5 | 2 | BU2 Sensor | Wheel Speed Difference | System has detected a significant difference in the proportion (6%) of tire diameter to number of tone ring teeth between wheel ends. | <ul style="list-style-type: none"> - Check for tire size mismatch. - Check for correct number of tone ring teeth. |
| 5 | 3 | BU2 Sensor | Shorted to UBATT | Continuity between the sensor connection and battery voltage (short circuit) is detected. | <ul style="list-style-type: none"> - Verify 900-2000 ohms resistance through sensor circuit. - Verify no DC voltage through sensor circuit Key ON. - Check for corroded or damaged wiring between the ECU and the ABS wheel speed sensor. |
| 5 | 4 | BU2 Sensor | Shorted to Ground | Continuity between the sensor connection and ground (short circuit) is detected. | <ul style="list-style-type: none"> - Check sensor, sensor cable and connectors to verify no loose or damaged connection. - Verify 900-2000 ohms resistance through sensor circuit. - Check for corroded or damaged wiring between the ECU and the ABS wheel speed sensor. - Swap sensor cable in question with adjacent sensor cable at the ECU. If the fault code stays in the same location, replace ECU. If the fault code changes locations, replace the suspect sensor. |
| 5 | 5 | BU2 Sensor | Open Circuit | An open circuit has been detected, i.e. ECU detects a disconnected wheel speed sensor. | <ul style="list-style-type: none"> - Check sensor, sensor cable and connectors to verify no loose or damaged connection. - Check for corroded or damaged wiring between the ECU and the ABS wheel speed sensor. - Check for corrosion or discoloration at ECU sensor pins and/or connector. - Visually inspect sensor extension female connector to ensure it is not out of round or spread resulting in intermittent contact with the ECU sensor pins. - Verify 900-2000 ohms resistance through sensor circuit. - Swap sensor cable in question with adjacent sensor cable at the ECU. If the fault code stays in the same location, replace ECU. If the fault code changes locations, replace the suspect sensor. |
| 5 | 6 | BU2 Sensor | Short Circuit | Continuity interruption between the sensor connections (short circuit) has been detected. | <ul style="list-style-type: none"> - Check for damaged or missing teeth on tone ring. - Verify tone ring is not corroded or with contamination. - Check for loose wheel bearings or excessive hub runout. - Swap sensor cable in question with adjacent sensor cable at the ECU. If the fault code stays in the same location, replace ECU. If the fault code changes locations, replace the suspect sensor. |

Diagnostics

| SID | FMI | Suspect Component and Location | Fault Description | Cause | Repair Information |
|-----|-----|--------------------------------|---------------------------------|---|---|
| 5 | 7 | BU2 Sensor | Tone Ring Damaged | Wheel speed signal drops out periodically at speeds higher than 6 mph. | <ul style="list-style-type: none"> - Check for damaged or missing teeth on tone ring. - Verify tone ring is not corroded or with contamination. - Check for loose wheel bearings or excessive hub runout. |
| 5 | 8 | BU2 Sensor | Excessive Slip | Wheel slip over 16 seconds continuously has been detected. | <ul style="list-style-type: none"> - Check tone ring. - Adjust wheel sensor to touch tone ring. - Inspect tone ring for damage. - Check sensor gap. - Check for loose wheel bearings or excessive hub runout. |
| 5 | 9 | BU2 Sensor | No Speed | A temporary loss of the ABS wheel speed signal has been detected. | <ul style="list-style-type: none"> - Adjust wheel speed sensor until it touches the tone ring. - Check for loose wheel bearings or excessive hub runout. - Check sensor wiring, cable routing and connectors for intermittent contact. - Check condition of ABS sensor head. - Check mounting of tone ring and condition of teeth. - Check condition and retention of ABS sensor spring clip. - Check for corroded or damaged wiring between the ECU and the ABS wheel speed sensor. - Turn the wheel at half a revolution per second and verify 0.2 AC volt sensor output voltage. |
| 5 | 10 | BU2 Sensor | Speed Jump Upwards or Downwards | Wheel speed difference. | <ul style="list-style-type: none"> - Adjust wheel speed sensor until it touches the tone ring. - Check for loose wheel bearings or excessive hub runout. - Check sensor wiring and connectors for intermittent contact. - Check condition of ABS sensor head. - Check mounting of tone ring and condition of teeth. - Check condition and retention of ABS sensor spring clip. - Check ABS sensor cable integrity. - Check for corroded or damaged wiring between the ECU and the ABS wheel speed sensor. - Turn the wheel at half a revolution per second and verify 0.2 AC volt sensor output voltage. |
| 5 | 11 | BU2 Sensor | Abnormal Speed (Chatter) | Brake drag or chatter has been detected. Abnormal vibrations detected which affect sensor signal. | <ul style="list-style-type: none"> - Check for loose wheel bearings or excessive hub runout. - Check sensor wiring and connectors for intermittent contact. - Check mounting of tone ring and condition of teeth. - Check condition and retention of ABS sensor spring clip as well as the mounting block. - Check for corroded or damaged wiring between the ECU and the ABS wheel speed sensor. - Turn the wheel at half a revolution per second and verify 0.2 AC volt sensor output voltage. |

Diagnostics

| SID | FMI | Suspect Component and Location | Fault Description | Cause | Repair Information |
|-----|-----|--------------------------------|----------------------------|---|--|
| 5 | 12 | BU2 Sensor | Software Interrupt Failure | A non-plausible sensor frequency has been measured. | <ul style="list-style-type: none"> - Check sensor wiring and connectors for intermittent contact. - Check if brake at this location is operating correctly, i.e., potentially dragging. - Check for corroded or damaged wiring between the ECU and the ABS wheel speed sensor. |
| 5 | 13 | BU2 Sensor | Wheel Speed Oscillating | Tone ring signal irregular. | <ul style="list-style-type: none"> - Check for loose wheel bearings or excessive hub runout. - Check sensor wiring and connectors for intermittent contact. - Check mounting of tone ring and condition of teeth. - If tone ring and sensor block are not aligned correctly, oscillation may occur. Small dimensional deviations can result in this failure code. Issue occurs shortly after going into service and after driving. - Check condition and retention of ABS sensor spring clip as well as the mounting block. - Check for corroded or damaged wiring between the ECU and the ABS wheel speed sensor. - Turn the wheel at half a revolution per second and verify 0.2 AC volt sensor output voltage. |
| 5 | 14 | BU2 Sensor | Sensor Not Found | Unexpected ECU configuration. | <ul style="list-style-type: none"> - Verify if system is a 4S/2M ECU and only 2 sensors are being used that they are plugged into the YE1 and BU1 ports on the ECU. - Verify no signs of moisture or corrosion at BU2 sensor port. - If a sensor has been installed on BU2 sensor port at some point and is no longer present, reconfigure the ECU using WABCO TOOLBOX™ diagnostic software. |
| 6 | 1 | YE2 Sensor | Air Gap | Sensor air gap is too large; sensor output voltage is too low but is high enough to be read by ECU. | <ul style="list-style-type: none"> - Adjust wheel sensor to touch tone ring. - Check condition of ABS sensor head. - Check for loose wheel bearings or excessive hub runout. - Check mounting of ABS tone ring and condition of teeth. - Check condition and retention of ABS sensor spring clip. - Turn the wheel at half a revolution per second and verify 0.2 AC volt sensor output voltage. |
| 6 | 2 | YE2 Sensor | Wheel Speed Difference | System has detected a significant difference in the proportion (6%) of tire diameter to number of tone ring teeth between wheel ends. | <ul style="list-style-type: none"> - Check for tire size mismatch. - Check for correct number of tone ring teeth. |
| 6 | 3 | YE2 Sensor | Shorted to UBATT | Continuity between the sensor connection and battery voltage (short circuit) is detected. | <ul style="list-style-type: none"> - Verify 900-2000 ohms resistance through sensor circuit. - Verify no DC voltage through sensor circuit Key ON. - Check for corroded or damaged wiring between the ECU and the ABS wheel speed sensor. |

Diagnostics

| SID | FMI | Suspect Component and Location | Fault Description | Cause | Repair Information |
|-----|-----|--------------------------------|-------------------|---|--|
| 6 | 4 | YE2 Sensor | Shorted to Ground | Continuity between the sensor connection and ground (short circuit) is detected. | <ul style="list-style-type: none"> - Check sensor, sensor cable and connectors to verify no loose or damaged connection. - Verify 900-2000 ohms resistance through sensor circuit. - Check for corroded or damaged wiring between the ECU and the ABS wheel speed sensor. - Swap sensor cable in question with adjacent sensor cable at the ECU. If the fault code stays in the same location, replace ECU. If the fault code changes locations, replace the suspect sensor. |
| 6 | 5 | YE2 Sensor | Open Circuit | An open circuit has been detected, i.e. ECU detects a disconnected wheel speed sensor. | <ul style="list-style-type: none"> - Check sensor, sensor cable and connectors to verify no loose or damaged connection. - Check for corroded or damaged wiring between the ECU and the ABS wheel speed sensor. - Check for corrosion or discoloration at ECU sensor pins and/or connector. - Visually inspect sensor extension female connector to ensure it is not out of round or spread resulting in intermittent contact with the ECU sensor pins. - Verify 900-2000 ohms resistance through sensor circuit. - Swap sensor cable in question with adjacent sensor cable at the ECU. If the fault code stays in the same location, replace ECU. If the fault code changes locations, replace the suspect sensor. |
| 6 | 6 | YE2 Sensor | Short Circuit | Continuity interruption between the sensor connections (short circuit) has been detected. | <ul style="list-style-type: none"> - Check for damaged or missing teeth on tone ring. - Verify tone ring is not corroded or with contamination. - Check for loose wheel bearings or excessive hub runout. - Swap sensor cable in question with adjacent sensor cable at the ECU. If the fault code stays in the same location, replace ECU. If the fault code changes locations, replace the suspect sensor. |
| 6 | 7 | YE2 Sensor | Tone Ring Damaged | Wheel speed signal drops out periodically at speeds higher than 6 mph. | <ul style="list-style-type: none"> - Check for damaged or missing teeth on tone ring. - Verify tone ring is not corroded or with contamination. - Check for loose wheel bearings or excessive hub runout. |
| 6 | 8 | YE2 Sensor | Excessive Slip | Wheel slip over 16 seconds continuously has been detected. | <ul style="list-style-type: none"> - Check tone ring. - Adjust wheel sensor to touch tone ring. - Inspect tone ring for damage. - Check sensor gap. - Check for loose wheel bearings or excessive hub runout. |

Diagnostics

| SID | FMI | Suspect Component and Location | Fault Description | Cause | Repair Information |
|-----|-----|--------------------------------|---------------------------------|---|---|
| 6 | 9 | YE2 Sensor | No Speed | A temporary loss of the ABS wheel speed signal has been detected. | <ul style="list-style-type: none"> - Adjust wheel speed sensor until it touches the tone ring. - Check for loose wheel bearings or excessive hub runout. - Check sensor wiring, cable routing and connectors for intermittent contact. - Check condition of ABS sensor head. - Check mounting of tone ring and condition of teeth. - Check condition and retention of ABS sensor spring clip. - Check for corroded or damaged wiring between the ECU and the ABS wheel speed sensor. - Turn the wheel at half a revolution per second and verify 0.2 AC volt sensor output voltage. |
| 6 | 10 | YE2 Sensor | Speed Jump Upwards or Downwards | Wheel speed difference. | <ul style="list-style-type: none"> - Adjust wheel speed sensor until it touches the tone ring. - Check for loose wheel bearings or excessive hub runout. - Check sensor wiring, cable routing and connectors for intermittent contact. - Check condition of ABS sensor head. - Check mounting of tone ring and condition of teeth. - Check condition and retention of ABS sensor spring clip. - Check for corroded or damaged wiring between the ECU and the ABS wheel speed sensor. - Turn the wheel at half a revolution per second and verify 0.2 AC volt sensor output voltage. |
| 6 | 11 | YE2 Sensor | Abnormal Speed (Chatter) | Brake drag or chatter has been detected. Abnormal vibrations detected which affect sensor signal. | <ul style="list-style-type: none"> - Check for loose wheel bearings or excessive hub runout. - Check sensor wiring, cable routing and connectors for intermittent contact. - Check mounting of tone ring and condition of teeth. - Check condition and retention of ABS sensor spring clip as well as the mounting block. - Check for corroded or damaged wiring between the ECU and the ABS wheel speed sensor. - Turn the wheel at half a revolution per second and verify 0.2 AC volt sensor output voltage. |
| 6 | 12 | YE2 Sensor | Software Interrupt Failure | A non-plausible sensor frequency has been measured. | <ul style="list-style-type: none"> - Check sensor wiring and connectors for intermittent contact. - Check if brake at this location is operating correctly, i.e., potentially dragging. - Check for corroded or damaged wiring between the ECU and the ABS wheel speed sensor. |

Diagnostics

| SID | FMI | Suspect Component and Location | Fault Description | Cause | Repair Information |
|-----|-----|-----------------------------------|--|---|--|
| 6 | 13 | YE2 Sensor | Wheel Speed Oscillating | Tone ring signal irregular. | <ul style="list-style-type: none"> - Check for loose wheel bearings or excessive hub runout. - Check sensor wiring and connectors for intermittent contact. - Check mounting of tone ring and condition of teeth. - If tone ring and sensor block are not aligned correctly, oscillation may occur. Small dimensional deviations can result in this failure code. Issue occurs shortly after going into service and after driving. - Check condition and retention of ABS sensor spring clip as well as the mounting block. - Check for corroded or damaged wiring between the ECU and the ABS wheel speed sensor. - Turn the wheel at half a revolution per second and verify 0.2 AC volt sensor output voltage. |
| 6 | 14 | YE2 Sensor | Sensor Not Found | Unexpected ECU configuration. | <ul style="list-style-type: none"> - Verify if system is a 4S/2M ECU and only 2 sensors are being used that they are plugged into the YE1 and BU1 ports on the ECU. - Verify no signs of moisture or corrosion at YE2 sensor port. - If a sensor has been installed on YE2 sensor port at some point and is no longer present, reconfigure the ECU using WABCO TOOLBOX™ diagnostic software. |
| 7 | 3 | External Modulator Valve (Red/RD) | External Modulator Valve Inlet/Outlet Valve Short Circuit to Battery | ABS ECU has detected a short to 12 VDC on the external modulator valve. | <ul style="list-style-type: none"> - Verify an external modulator is installed by checking to see if a cable is plugged in to the external modulator port of the ABS ECU. - Verify if no cable is attached, that the external modulator cap is sealed and there are no signs of moisture or corrosion on the pins of the ABS ECU. - If no external modulator valve is used and all previous checks pass, reconfigure the system to a 2S/2M or 4S/2M system depending on how many sensors are used through the WABCO TOOLBOX™ Software. - If equipped with an external modulator verify resistance from the exhaust and inlet valve to ground is between 4 to 8 ohms through the whole circuit. - Verify there is no voltage on any of the pins of the external modulator valve cable to chassis ground. |
| 7 | 4 | External Modulator Valve (Red/RD) | External Modulator Valve Inlet/Outlet Valve Short Circuit to Ground | ABS ECU has detected a short to ground on the external modulator valve. | <ul style="list-style-type: none"> - Verify an external modulator is installed by checking to see if a cable is plugged in to the external modulator port of the ABS ECU. - Verify if no cable is attached that the external modulator cap is sealed and there are no signs of moisture or corrosion on the pins of the ABS ECU. - If no external modulator valve is used and all previous checks pass, reconfigure the system to a 2S/2M or 4S/2M system depending on how many sensors are used through the WABCO TOOLBOX™ Software. - If equipped with an external modulator verify resistance from the exhaust and inlet valve to ground is between 4 to 8 ohms through the whole circuit. - Verify there is no continuity on any of the pins of the external modulator valve cable to chassis ground. |

Diagnostics

| SID | FMI | Suspect Component and Location | Fault Description | Cause | Repair Information |
|-----|-----|---|--|---|--|
| 7 | 5 | External Modulator Valve (Red/RD) | External Modulator Valve Inlet/Outlet Valve Open Circuit | ABS ECU has detected an open circuit on the external modulator valve. | <ul style="list-style-type: none"> - Verify an external modulator is installed by checking to see if a cable is plugged in to the external modulator port of the ABS ECU. - Verify if no cable is attached that the external modulator cap is sealed and there are no signs of moisture or corrosion on the pins of the ABS ECU. - If no external modulator valve is used and all previous checks pass, reconfigure the system to a 2S/2M or 4S/2M system depending on how many sensors are used through the WABCO TOOLBOX™ Software. - If equipped with an external modulator verify resistance from the exhaust and inlet valve to ground is between 4 to 8 ohms through the whole circuit. - Verify there is no continuity on any of the pins of the external modulator valve cable to chassis ground. |
| 7 | 14 | External Modulator Valve (Red/RD) | External Modulator Valve Inlet/Outlet Valve not Found | Unexpected ECU configuration. | <ul style="list-style-type: none"> - Verify an external modulator is installed by checking to see if a cable is plugged in to the external modulator port of the ABS ECU. - Verify if no cable is attached that the external modulator cap is sealed and there are no signs of moisture or corrosion on the pins of the ABS ECU. - If no external modulator valve is used reconfigure the system to a 2S/2M or 4S/2M system depending on how many sensors are used through the WABCO TOOLBOX™ Software. |
| 9 | 3 | Internal Modulator Inlet Valve #2 (Blue/BU) | Internal Modulator Inlet Valve Short Circuit to Battery | ABS ECU has detected a short to 12 VDC on the modulator valve. | <ul style="list-style-type: none"> - Verify the ABS ECU power connector is seated correctly and has no signs of moisture or corrosion. - Verify correct power, ground at the main ABS ECU power connector and load test the power and ground circuit. |
| 9 | 4 | Internal Modulator Inlet Valve #2 (Blue/BU) | Internal Modulator Inlet Valve Short Circuit to Ground | ABS ECU has detected a short to ground on the modulator valve. | <ul style="list-style-type: none"> - Verify the ABS ECU power connector is seated correctly and has no signs of moisture or corrosion. - Verify correct power, ground at the main ABS ECU power connector and load test the power and ground circuit. |
| 9 | 5 | Internal Modulator Inlet Valve #2 (Blue/BU) | Internal Modulator Inlet Valve Open Circuit | ABS ECU has detected an open circuit on the modulator valve. | <ul style="list-style-type: none"> - Verify the ABS ECU power connector is seated correctly and has no signs of moisture or corrosion. - Verify correct power, ground at the main ABS ECU power connector and load test the power and ground circuit. |
| 10 | 3 | Internal Modulator Inlet Valve #1 (Yellow/YE) | Internal Modulator Inlet Valve Short Circuit to Battery | ABS ECU has detected a short to 12 VDC on the valve assembly. | <ul style="list-style-type: none"> - Verify the ABS ECU power connector is seated correctly and has no signs of moisture or corrosion. - Verify correct power, ground at the main ABS ECU power connector and load test the power and ground circuit. |
| 10 | 4 | Internal Modulator Inlet Valve #1 (Yellow/YE) | Internal Modulator Inlet Valve Short Circuit to Ground | ABS ECU has detected a short to ground on the valve assembly. | <ul style="list-style-type: none"> - Verify the ABS ECU power connector is seated correctly and has no signs of moisture or corrosion. - Verify correct power, ground at the main ABS ECU power connector and load test the power and ground circuit. |

Diagnostics

| SID | FMI | Suspect Component and Location | Fault Description | Cause | Repair Information |
|-----|-----|---|---|--|---|
| 10 | 5 | Internal Modulator Inlet Valve #1 (Yellow/YE) | Internal Modulator Inlet Valve Open Circuit | ABS ECU has detected an open circuit on the valve assembly. | <ul style="list-style-type: none"> - Verify the ABS ECU power connector is seated correctly and has no signs of moisture or corrosion. - Verify correct power, ground at the main ABS ECU power connector and load test the power and ground circuit. |
| 11 | 3 | Internal Modulator Outlet Valve | Internal Modulator Inlet Valve Short Circuit to Battery | ABS ECU has detected a short to 12 VDC on the internal solenoid. | <ul style="list-style-type: none"> - Verify the ABS ECU power connector is seated correctly and has no signs of moisture or corrosion. - Verify correct power, ground at the main ABS ECU power connector and load test the power and ground circuit. |
| 11 | 4 | Internal Modulator Outlet Valve | Internal Modulator Inlet Valve Short Circuit to Ground | ABS ECU has detected a short to ground on the internal solenoid. | <ul style="list-style-type: none"> - Verify the ABS ECU power connector is seated correctly and has no signs of moisture or corrosion. - Verify correct power, ground at the main ABS ECU power connector and load test the power and ground circuit. |
| 11 | 5 | Internal Modulator Outlet Valve | Internal Modulator Inlet Valve Open Circuit | ABS ECU has detected an open circuit on the internal solenoid. | <ul style="list-style-type: none"> - Verify the ABS ECU power connector is seated correctly and has no signs of moisture or corrosion. - Verify correct power, ground at the main ABS ECU power connector and load test the power and ground circuit. |
| 19 | 3 | GIO Components | Short Circuit to Battery at GIO-D1 | ECU has detected a short circuit of the GIO-D1 to battery. | <ul style="list-style-type: none"> - Verify connectors are correctly seated and have no signs of moisture or corrosion. - Check for signs of damage to the cable or connectors. - Verify good continuity for the GIO circuit. - Verify the GIO circuit is not shorted to voltage. |
| 19 | 4 | GIO Components | Short Circuit to Ground at GIO-D1 | ECU has detected a short circuit of the GIO-D1 to battery. | <ul style="list-style-type: none"> - Verify connectors are correctly seated and have no signs of moisture or corrosion. - Check for signs of damage to the cable or connectors. - Verify good continuity for the GIO circuit. - Verify the GIO circuit is not shorted to ground. |
| 19 | 5 | GIO Components | Cable Break at GIO-D1 | ECU has detected an open circuit of the GIO-D1. | <ul style="list-style-type: none"> - Verify connectors are correctly seated and have no signs of moisture or corrosion. - Check for signs of damage to the cable or connectors. - Verify good continuity for the GIO circuit. - Verify the GIO circuit is not open. |
| 19 | 12 | GIO Components | GIO Channel 1 Logic Failure | ECU has detected a failure of the GIO logic. | <ul style="list-style-type: none"> - Verify the ABS ECU power connector is seated correctly and has no signs of moisture or corrosion. - Verify correct power, ground at the main ABS ECU power connector and load test the power and ground circuit. - Verify correct GIO setup, TIO parameter file, device and cables. |
| 20 | 3 | GIO Components | Short Circuit to Battery at GIO-D2 | ECU has detected a short circuit of the GIO-D2 to battery. | <ul style="list-style-type: none"> - Verify connectors are correctly seated and have no signs of moisture or corrosion. - Check for signs of damage to the cable or connectors. - Verify good continuity for the GIO circuit. - Verify the GIO circuit is not shorted to voltage. |

Diagnostics

| SID | FMI | Suspect Component and Location | Fault Description | Cause | Repair Information |
|-----|-----|--------------------------------|------------------------------------|--|---|
| 20 | 4 | GIO Components | Short Circuit to Ground at GIO-D2 | ECU has detected a short circuit of the GIO-D2 to battery. | <ul style="list-style-type: none"> - Verify connectors are correctly seated and have no signs of moisture or corrosion. - Check for signs of damage to the cable or connectors. - Verify good continuity for the GIO circuit. - Verify the GIO circuit is not shorted to ground. |
| 20 | 5 | GIO Components | Cable Break at GIO-D2 | ECU has detected an open circuit of the GIO-D2. | <ul style="list-style-type: none"> - Verify connectors are correctly seated and have no signs of moisture or corrosion. - Check for signs of damage to the cable or connectors. - Verify good continuity for the GIO circuit. - Verify the GIO circuit is not open. |
| 20 | 12 | GIO Components | GIO Channel 2 Logic Failure | ECU has detected a failure of the GIO logic. | <ul style="list-style-type: none"> - Verify the ABS ECU power connector is seated correctly and has no signs of moisture or corrosion. - Verify correct power, ground at the main ABS ECU power connector and load test the power and ground circuit. - Verify correct GIO setup, TIO parameter file, device and cables. |
| 21 | 3 | GIO Components | Short Circuit to Battery at GIO-D3 | ECU has detected a short circuit of the GIO-D3 to battery. | <ul style="list-style-type: none"> - Verify connectors are correctly seated and have no signs of moisture or corrosion. - Check for signs of damage to the cable or connectors. - Verify good continuity for the GIO circuit. - Verify the GIO circuit is not shorted to voltage. |
| 21 | 4 | GIO Components | Short Circuit to Ground at GIO-D3 | ECU has detected a short circuit of the GIO-D3 to battery. | <ul style="list-style-type: none"> - Verify connectors are correctly seated and have no signs of moisture or corrosion. - Check for signs of damage to the cable or connectors. - Verify good continuity for the GIO circuit. - Verify the GIO circuit is not shorted to ground. |
| 21 | 5 | GIO Components | Cable Break at GIO-D3 | ECU has detected an open circuit of the GIO-D3. | <ul style="list-style-type: none"> - Verify connectors are correctly seated and have no signs of moisture or corrosion. - Check for signs of damage to the cable or connectors. - Verify good continuity for the GIO circuit. - Verify the GIO circuit is not open. |
| 21 | 12 | GIO Components | GIO Channel 3 Logic Failure | ECU has detected a failure of the GIO logic. | <ul style="list-style-type: none"> - Verify the ABS ECU power connector is seated correctly and has no signs of moisture or corrosion. - Verify correct power, ground at the main ABS ECU power connector and load test the power and ground circuit. - Verify correct GIO setup, TIO parameter file, device and cables. |
| 22 | 3 | GIO Components | Short Circuit to Battery at GIO-D4 | ECU has detected a short circuit of the GIO-D4 to battery. | <ul style="list-style-type: none"> - Verify connectors are correctly seated and have no signs of moisture or corrosion. - Check for signs of damage to the cable or connectors. - Verify good continuity for the GIO circuit. - Verify the GIO circuit is not shorted to voltage. |

Diagnostics

| SID | FMI | Suspect Component and Location | Fault Description | Cause | Repair Information |
|-----|-----|--------------------------------|------------------------------------|--|---|
| 22 | 4 | GIO Components | Short Circuit to Ground at GIO-D4 | ECU has detected a short circuit of the GIO-D4 to battery. | <ul style="list-style-type: none"> - Verify connectors are correctly seated and have no signs of moisture or corrosion. - Check for signs of damage to the cable or connectors. - Verify good continuity for the GIO circuit. - Verify the GIO circuit is not shorted to ground. |
| 22 | 5 | GIO Components | Cable Break at GIO-D4 | ECU has detected an open circuit of the GIO-D4. | <ul style="list-style-type: none"> - Verify connectors are correctly seated and have no signs of moisture or corrosion. - Check for signs of damage to the cable or connectors. - Verify good continuity for the GIO circuit. - Verify the GIO circuit is not open. |
| 22 | 12 | GIO Components | GIO Channel 4 Logic Failure | ECU has detected a failure of the GIO logic. | <ul style="list-style-type: none"> - Verify the ABS ECU power connector is seated correctly and has no signs of moisture or corrosion. - Verify correct power, ground at the main ABS ECU power connector and load test the power and ground circuit. - Verify correct GIO setup, TIO parameter file, device and cables. |
| 23 | 3 | GIO Components | Short Circuit to Battery at GIO-D5 | ECU has detected a short circuit of the GIO-D5 to battery. | <ul style="list-style-type: none"> - Verify connectors are correctly seated and have no signs of moisture or corrosion. - Check for signs of damage to the cable or connectors. - Verify good continuity for the GIO circuit. - Verify the GIO circuit is not shorted to voltage. |
| 23 | 4 | GIO Components | Short Circuit to Ground at GIO-D5 | ECU has detected a short circuit of the GIO-D5 to battery. | <ul style="list-style-type: none"> - Verify connectors are correctly seated and have no signs of moisture or corrosion. - Check for signs of damage to the cable or connectors. - Verify good continuity for the GIO circuit. - Verify the GIO circuit is not shorted to ground. |
| 23 | 5 | GIO Components | Cable Break at GIO-D5 | ECU has detected an open circuit of the GIO-D5. | <ul style="list-style-type: none"> - Verify connectors are correctly seated and have no signs of moisture or corrosion. - Check for signs of damage to the cable or connectors. - Verify good continuity for the GIO circuit. - Verify the GIO circuit is not open. |
| 23 | 12 | GIO Components | GIO Channel 5 Logic Failure | ECU has detected a failure of the GIO logic. | <ul style="list-style-type: none"> - Verify the ABS ECU power connector is seated correctly and has no signs of moisture or corrosion. - Verify correct power, ground at the main ABS ECU power connector and load test the power and ground circuit. - Verify correct GIO setup, parameter file, device and cables. |
| 24 | 3 | GIO Components | Short Circuit to Battery at GIO-A1 | ECU has detected a short circuit of the GIO-A1 to battery. | <ul style="list-style-type: none"> - Verify connectors are correctly seated and have no signs of moisture or corrosion. - Check for signs of damage to the cable or connectors. - Verify good continuity for the GIO circuit. - Verify the GIO circuit is not shorted to voltage. |

Diagnostics

| SID | FMI | Suspect Component and Location | Fault Description | Cause | Repair Information |
|-----|-----|--------------------------------|------------------------------------|--|---|
| 24 | 4 | GIO Components | Short Circuit to Ground at GIO-A1 | ECU has detected a short circuit of the GIO-A1 to battery. | <ul style="list-style-type: none"> - Verify connectors are correctly seated and have no signs of moisture or corrosion. - Check for signs of damage to the cable or connectors. - Verify good continuity for the GIO circuit. - Verify the GIO circuit is not shorted to ground. |
| 24 | 5 | GIO Components | Cable Break at GIO-A1 | ECU has detected an open circuit of the GIO-A1. | <ul style="list-style-type: none"> - Verify connectors are correctly seated and have no signs of moisture or corrosion. - Check for signs of damage to the cable or connectors. - Verify good continuity for the GIO circuit. - Verify the GIO circuit is not open. |
| 24 | 12 | GIO Components | GIO Channel 6 Logic Failure | ECU has detected a failure of the GIO logic. | <ul style="list-style-type: none"> - Verify the ABS ECU power connector is seated correctly and has no signs of moisture or corrosion. - Verify correct power, ground at the main ABS ECU power connector and load test the power and ground circuit. - Verify correct GIO setup, TIO parameter file, device and cables. |
| 25 | 3 | GIO Components | Short Circuit to Battery at GIO-A2 | ECU has detected a short circuit of the GIO-A2 to battery. | <ul style="list-style-type: none"> - Verify connectors are correctly seated and have no signs of moisture or corrosion. - Check for signs of damage to the cable or connectors. - Verify good continuity for the GIO circuit. - Verify the GIO circuit is not shorted to voltage. |
| 25 | 4 | GIO Components | Short Circuit to Ground at GIO-A2 | ECU has detected a short circuit of the GIO-A2 to battery. | <ul style="list-style-type: none"> - Verify connectors are correctly seated and have no signs of moisture or corrosion. - Check for signs of damage to the cable or connectors. - Verify good continuity for the GIO circuit. - Verify the GIO circuit is not shorted to ground. |
| 25 | 5 | GIO Components | Cable Break at GIO-A2 | ECU has detected an open circuit of the GIO-A2. | <ul style="list-style-type: none"> - Verify connectors are correctly seated and have no signs of moisture or corrosion. - Check for signs of damage to the cable or connectors. - Verify good continuity for the GIO circuit. - Verify the GIO circuit is not open. |
| 25 | 12 | GIO Components | GIO Channel 7 Logic Failure | ECU has detected a failure of the GIO logic. | <ul style="list-style-type: none"> - Verify the ABS ECU power connector is seated correctly and has no signs of moisture or corrosion. - Verify correct power, ground at the main ABS ECU power connector and load test the power and ground circuit. - Verify correct GIO setup, TIO parameter file, device and cables. |
| 26 | 3 | GIO Components | Sensor Power Supply Error | ECU has detected a GIO sensor power error. | <ul style="list-style-type: none"> - Verify connectors are correctly seated and have no signs of moisture or corrosion. - Check for signs of damage to the cable or connectors. - Verify good continuity for the GIO circuit. |
| 26 | 4 | GIO Components | Sensor Power Supply No Power | ECU has detected a GIO sensor power error (no power). | <ul style="list-style-type: none"> - Verify connectors are correctly seated and have no signs of moisture or corrosion. - Check for signs of damage to the cable or connectors. - Verify good continuity for the GIO circuit. |

Diagnostics

| SID | FMI | Suspect Component and Location | Fault Description | Cause | Repair Information |
|-----|-----|--------------------------------|---|--|---|
| 26 | 12 | GIO Components | GIO Channel 8 Logic Failure | ECU has detected a failure of the GIO logic. | <ul style="list-style-type: none"> - Verify the ABS ECU power connector is seated correctly and has no signs of moisture or corrosion. - Verify correct power, ground at the main ABS ECU power connector and load test the power and ground circuit. - Verify correct GIO setup, TIO parameter file, device and cables. |
| 27 | 2 | ABS ECU/Power Supply | J2497 Broadcast Breakdown | ECU cannot communicate on the J2497 data bus. | <ul style="list-style-type: none"> - Verify the ABS ECU power connector is seated correctly and has no signs of moisture or corrosion. - Verify correct power, ground at the main ABS ECU power connector and load test the power and ground circuit. |
| 27 | 15 | ABS ECU/Power Supply | J2497 Failure | ECU cannot communicate on the J2497 data bus. | <ul style="list-style-type: none"> - Verify the ABS ECU power connector is seated correctly and has no signs of moisture or corrosion. - Verify correct power, ground at the main ABS ECU power connector and load test the power and ground circuit. |
| 58 | 15 | ABS ECU/Power Supply | J1708 Failure | ECU cannot communicate on the J1708 data bus. | <ul style="list-style-type: none"> - Verify the ABS ECU power connector is seated correctly and has no signs of moisture or corrosion. - Verify correct power, ground at the main ABS ECU power connector and load test the power and ground circuit. - Verify diagnostic cable is correctly seated, no sign of moisture or corrosion. - Verify diagnostic cable has good continuity end to end, for Enhanced Easy Stop system check pins 7 to B and pins 8 to A. For Easy Stop systems check pins 1 to A and 2 to B, also verify wires are not shorted to ground, voltage or each other. |
| 59 | 1 | ABS ECU/Power Supply | Low Voltage Warning | ABS ECU has detected an under-voltage condition. | <ul style="list-style-type: none"> - Verify the ABS ECU power connector is seated correctly and has no signs of moisture or corrosion. - Verify correct power, ground at the main ABS ECU power connector and load test the power and ground circuit. - Verify output of towing vehicle voltage regulator. |
| 59 | 3 | ABS ECU/Power Supply | High Voltage | ABS ECU has detected an over-voltage condition. | <ul style="list-style-type: none"> - Verify the ABS ECU power connector is seated correctly and has no signs of moisture or corrosion. - Verify correct power, ground at the main ABS ECU power connector and load test the power and ground circuit. - Verify output of towing vehicle voltage regulator. |
| 59 | 4 | ABS ECU/Power Supply | Low Voltage | ABS ECU has detected an under-voltage condition. | <ul style="list-style-type: none"> - Verify the ABS ECU power connector is seated correctly and has no signs of moisture or corrosion. - Verify output of towing vehicle voltage regulator. |
| 59 | 8 | ABS ECU/Power Supply | Intermittent Contact at Stop Light Power Supply | ABS ECU has detected an under-voltage condition. | <ul style="list-style-type: none"> - Verify the ABS ECU power connector is seated correctly and has no signs of moisture or corrosion. - Verify correct constant power, stop light power and ground at the main ABS ECU power connector and load test the power and ground circuit. - Verify towing vehicle output through the stop light circuit. |

Diagnostics

| SID | FMI | Suspect Component and Location | Fault Description | Cause | Repair Information |
|-----|-----|--------------------------------|---|--|---|
| 59 | 9 | ABS ECU/Power Supply | CPU Internal Error | ABS ECU has detected an internal error. | <ul style="list-style-type: none"> - Verify the ABS ECU power connector is seated correctly and has no signs of moisture or corrosion. - Verify correct power, ground at the main ABS ECU power connector and load test the power and ground circuit. |
| 59 | 10 | ABS ECU/Power Supply | Intermittent Contact at Constant Power Supply | ABS ECU has detected an under-voltage condition. | <ul style="list-style-type: none"> - Verify the ABS ECU power connector is seated correctly and has no signs of moisture or corrosion. - Verify correct power, ground at the main ABS ECU power connector and load test the power and ground circuit. - Verify output of towing vehicle voltage regulator. |
| 59 | 12 | ABS ECU/Power Supply | CPU Internal Error | ABS ECU has detected an internal error. | <ul style="list-style-type: none"> - Verify the ABS ECU power connector is seated correctly and has no signs of moisture or corrosion. - Verify correct power, ground at the main ABS ECU power connector and load test the power and ground circuit. |
| 59 | 14 | ABS ECU/Power Supply | Power Supply Impedance Failure | ABS ECU has detected an internal error. | <ul style="list-style-type: none"> - Verify the ABS ECU power connector is seated correctly and has no signs of moisture or corrosion. |
| 61 | 2 | ABS ECU/Power Supply | Parameter Failure | ECU parameter error. | <ul style="list-style-type: none"> - Verify ABS ECU has correct configuration based on how many ABS sensors and modulator valves it is equipped with. - Reconfigure to correct system configuration using the WABCO TOOLBOX™ Software based on how many ABS sensors and modulators are used. |
| 61 | 12 | ABS ECU/Power Supply | Checksum/EEPROM Failure | ECU parameter error detected. | <ul style="list-style-type: none"> - Verify the ABS ECU power connector is seated correctly and has no signs of moisture or corrosion. - Verify correct power, ground at the main ABS ECU power connector and load test the power and ground circuit. |
| 61 | 13 | ABS ECU/Power Supply | GIO D4/D5 Parameter Failure | Internal error. | <ul style="list-style-type: none"> - Verify correct power, ground at the main ABS ECU power connector and load test the power and ground circuit. - Check communication between TOOLBOX and the ECU. - Verify correct GIO setup. |
| 61 | 14 | ABS ECU/Power Supply | Customer EOL Test Invalid | ECU parameter error detected. | <ul style="list-style-type: none"> - Verify correct power, ground at the main ABS ECU power connector and load test the power and ground circuit. - Check communication between TOOLBOX and the ECU. |
| 62 | 2 | ABS ECU/Power Supply | CPU Internal Error | ABS ECU has detected an internal error. | <ul style="list-style-type: none"> - Verify the ABS ECU power connector is seated correctly and has no signs of moisture or corrosion. - Verify correct power, ground at the main ABS ECU power connector and load test the power and ground circuit. |
| 62 | 12 | ABS ECU/Power Supply | Checksum Failure ROM | ABS ECU has detected an internal error. | <ul style="list-style-type: none"> - Verify the ABS ECU power connector is seated correctly and has no signs of moisture or corrosion. - Verify correct power, ground at the main ABS ECU power connector and load test the power and ground circuit. |

Diagnostics

| SID | FMI | Suspect Component and Location | Fault Description | Cause | Repair Information |
|-----|-----|--------------------------------|------------------------------------|--|---|
| 62 | 15 | ABS ECU/Power Supply | CPU Internal Error | Internal short to controller. | <ul style="list-style-type: none"> - Verify the ABS ECU power connector is seated correctly and has no signs of moisture or corrosion. - Verify correct power, ground at the main ABS ECU power connector and load test the power and ground circuit. |
| 211 | 3 | GIO Components | Short Circuit to Battery at GIO-D1 | ECU has detected a short circuit of the GIO-D1 to battery. | <ul style="list-style-type: none"> - Verify connectors are correctly seated and have no signs of moisture or corrosion. - Check for signs of damage to the cable or connectors. - Verify good continuity for the GIO circuit. - Verify the GIO circuit is not shorted to voltage. |
| 211 | 4 | GIO Components | Short Circuit to Ground at GIO-D1 | ECU has detected a short circuit of the GIO-D1 to battery. | <ul style="list-style-type: none"> - Verify connectors are correctly seated and have no signs of moisture or corrosion. - Check for signs of damage to the cable or connectors. - Verify good continuity for the GIO circuit. - Verify the GIO circuit is not shorted to ground. |
| 211 | 5 | GIO Components | Cable Break at GIO-D1 | ECU has detected an open circuit of the GIO-D1. | <ul style="list-style-type: none"> - Verify connectors are correctly seated and have no signs of moisture or corrosion. - Check for signs of damage to the cable or connectors. - Verify good continuity for the GIO circuit. - Verify the GIO circuit is not open. |
| 211 | 12 | GIO Components | GIO-D1 Logic Failure | ECU has detected a failure of the GIO logic. | <ul style="list-style-type: none"> - Verify the ABS ECU power connector is seated correctly and has no signs of moisture or corrosion. - Verify correct power, ground at the main ABS ECU power connector and load test the power and ground circuit. - Verify correct GIO setup. |
| 212 | 3 | GIO Components | Short Circuit to Battery at GIO-D2 | ECU has detected a short circuit of the GIO-D2 to battery. | <ul style="list-style-type: none"> - Verify connectors are correctly seated and have no signs of moisture or corrosion. - Check for signs of damage to the cable or connectors. - Verify good continuity for the GIO circuit. - Verify the GIO circuit is not shorted to voltage. |
| 212 | 4 | GIO Components | Short Circuit to Ground at GIO-D2 | ECU has detected a short circuit of the GIO-D2 to battery. | <ul style="list-style-type: none"> - Verify connectors are correctly seated and have no signs of moisture or corrosion. - Check for signs of damage to the cable or connectors. - Verify good continuity for the GIO circuit. - Verify the GIO circuit is not shorted to ground. |
| 212 | 5 | GIO Components | Cable Break at GIO-D2 | ECU has detected an open circuit of the GIO-D2. | <ul style="list-style-type: none"> - Verify connectors are correctly seated and have no signs of moisture or corrosion. - Check for signs of damage to the cable or connectors. - Verify good continuity for the GIO circuit. - Verify the GIO circuit is not open. |
| 212 | 12 | GIO Components | GIO-D2 Logic Failure | ECU has detected a failure of the GIO logic. | <ul style="list-style-type: none"> - Verify the ABS ECU power connector is seated correctly and has no signs of moisture or corrosion. - Verify correct power, ground at the main ABS ECU power connector and load test the power and ground circuit. - Verify correct GIO setup. |

Diagnostics

| SID | FMI | Suspect Component and Location | Fault Description | Cause | Repair Information |
|-----|-----|--------------------------------|------------------------------------|--|---|
| 213 | 3 | GIO Components | Short Circuit to Battery at GIO-D3 | ECU has detected a short circuit of the GIO-D3 to battery. | <ul style="list-style-type: none"> - Verify connectors are correctly seated and have no signs of moisture or corrosion. - Check for signs of damage to the cable or connectors. - Verify good continuity for the GIO circuit. - Verify the GIO circuit is not shorted to voltage. |
| 213 | 4 | GIO Components | Short Circuit to Ground at GIO-D3 | ECU has detected a short circuit of the GIO-D3 to battery. | <ul style="list-style-type: none"> - Verify connectors are correctly seated and have no signs of moisture or corrosion. - Check for signs of damage to the cable or connectors. - Verify good continuity for the GIO circuit. - Verify the GIO circuit is not shorted to ground. |
| 213 | 5 | GIO Components | Cable Break at GIO-D3 | ECU has detected an open circuit of the GIO-D3. | <ul style="list-style-type: none"> - Verify connectors are correctly seated and have no signs of moisture or corrosion. - Check for signs of damage to the cable or connectors. - Verify good continuity for the GIO circuit. - Verify the GIO circuit is not open. |
| 213 | 12 | GIO Components | GIO-D3 Logic Failure | ECU has detected a failure of the GIO logic. | <ul style="list-style-type: none"> - Verify the ABS ECU power connector is seated correctly and has no signs of moisture or corrosion. - Verify correct power, ground at the main ABS ECU power connector and load test the power and ground circuit. - Verify correct GIO setup. |
| 214 | 3 | GIO Components | Short Circuit to Battery at GIO-D4 | ECU has detected a short circuit of the GIO-D4 to battery. | <ul style="list-style-type: none"> - Verify connectors are correctly seated and have no signs of moisture or corrosion. - Check for signs of damage to the cable or connectors. - Verify good continuity for the GIO circuit. - Verify the GIO circuit is not shorted to voltage. |
| 214 | 4 | GIO Components | Short Circuit to Ground at GIO-D4 | ECU has detected a short circuit of the GIO-D4 to battery. | <ul style="list-style-type: none"> - Verify connectors are correctly seated and have no signs of moisture or corrosion. - Check for signs of damage to the cable or connectors. - Verify good continuity for the GIO circuit. - Verify the GIO circuit is not shorted to ground. |
| 214 | 5 | GIO Components | Cable Break at GIO-D4 | ECU has detected an open circuit of the GIO-D4. | <ul style="list-style-type: none"> - Verify connectors are correctly seated and have no signs of moisture or corrosion. - Check for signs of damage to the cable or connectors. - Verify good continuity for the GIO circuit. - Verify the GIO circuit is not open. |
| 214 | 12 | GIO Components | GIO-D4 Logic Failure | ECU has detected a failure of the GIO logic. | <ul style="list-style-type: none"> - Verify the ABS ECU power connector is seated correctly and has no signs of moisture or corrosion. - Verify correct power, ground at the main ABS ECU power connector and load test the power and ground circuit. - Verify correct GIO setup. |
| 215 | 3 | GIO Components | Short Circuit to Battery at GIO-D5 | ECU has detected a short circuit of the GIO-D5 to battery. | <ul style="list-style-type: none"> - Verify connectors are correctly seated and have no signs of moisture or corrosion. - Check for signs of damage to the cable or connectors. - Verify good continuity for the GIO circuit. - Verify the GIO circuit is not shorted to voltage. |

Diagnostics

| SID | FMI | Suspect Component and Location | Fault Description | Cause | Repair Information |
|-----|-----|--------------------------------|------------------------------------|--|---|
| 215 | 4 | GIO Components | Short Circuit to Ground at GIO-D5 | ECU has detected a short circuit of the GIO-D5 to battery. | <ul style="list-style-type: none"> - Verify connectors are correctly seated and have no signs of moisture or corrosion. - Check for signs of damage to the cable or connectors. - Verify good continuity for the GIO circuit. - Verify the GIO circuit is not shorted to ground. |
| 215 | 5 | GIO Components | Cable Break at GIO-D5 | ECU has detected an open circuit of the GIO-D5. | <ul style="list-style-type: none"> - Verify connectors are correctly seated and have no signs of moisture or corrosion. - Check for signs of damage to the cable or connectors. - Verify good continuity for the GIO circuit. - Verify the GIO circuit is not open. |
| 215 | 12 | GIO Components | GIO-D5 Logic Failure | ECU has detected a failure of the GIO logic. | <ul style="list-style-type: none"> - Verify the ABS ECU power connector is seated correctly and has no signs of moisture or corrosion. - Verify correct power, ground at the main ABS ECU power connector and load test the power and ground circuit. - Verify correct GIO setup. |
| 216 | 3 | GIO Components | Short Circuit to Battery at GIO-A1 | ECU has detected a short circuit of the GIO-A1 to battery. | <ul style="list-style-type: none"> - Verify connectors are correctly seated and have no signs of moisture or corrosion. - Check for signs of damage to the cable or connectors. - Verify good continuity for the GIO circuit. - Verify the GIO circuit is not shorted to voltage. |
| 216 | 4 | GIO Components | Short Circuit to Ground at GIO-A1 | ECU has detected a short circuit of the GIO-A1 to battery. | <ul style="list-style-type: none"> - Verify connectors are correctly seated and have no signs of moisture or corrosion. - Check for signs of damage to the cable or connectors. - Verify good continuity for the GIO circuit. - Verify the GIO circuit is not shorted to ground. |
| 216 | 5 | GIO Components | Cable Break at GIO-A1 | ECU has detected an open circuit of the GIO-A1. | <ul style="list-style-type: none"> - Verify connectors are correctly seated and have no signs of moisture or corrosion. - Check for signs of damage to the cable or connectors. - Verify good continuity for the GIO circuit. - Verify the GIO circuit is not open. |
| 216 | 12 | GIO Components | GIO-A1 Logic Failure | ECU has detected a failure of the GIO logic. | <ul style="list-style-type: none"> - Verify the ABS ECU power connector is seated correctly and has no signs of moisture or corrosion. - Verify correct power, ground at the main ABS ECU power connector and load test the power and ground circuit. - Verify correct GIO setup. |
| 217 | 3 | GIO Components | Short Circuit to Battery at GIO-A2 | ECU has detected a short circuit of the GIO-A2 to battery. | <ul style="list-style-type: none"> - Verify connectors are correctly seated and have no signs of moisture or corrosion. - Check for signs of damage to the cable or connectors. - Verify good continuity for the GIO circuit. - Verify the GIO circuit is not shorted to voltage. |
| 217 | 4 | GIO Components | Short Circuit to Ground at GIO-A2 | ECU has detected a short circuit of the GIO-A2 to battery. | <ul style="list-style-type: none"> - Verify connectors are correctly seated and have no signs of moisture or corrosion. - Check for signs of damage to the cable or connectors. - Verify good continuity for the GIO circuit. - Verify the GIO circuit is not shorted to ground. |

Diagnostics

| SID | FMI | Suspect Component and Location | Fault Description | Cause | Repair Information |
|-----|-----|--------------------------------|----------------------------------|---|---|
| 217 | 5 | GIO Components | Cable Break at GIO-A2 | ECU has detected an open circuit of the GIO-A2. | <ul style="list-style-type: none"> - Verify connectors are correctly seated and have no signs of moisture or corrosion. - Verify good continuity for the GIO circuit. - Verify the GIO circuit is not open. |
| 217 | 12 | GIO Components | GIO-A2 Logic Failure | ECU has detected a failure of the GIO logic. | <ul style="list-style-type: none"> - Verify the ABS ECU power connector is seated correctly and has no signs of moisture or corrosion. - Verify correct power, ground at the main ABS ECU power connector and load test the power and ground circuit. - Verify correct GIO setup. |
| 218 | 3 | GIO Components | Sensor Power Supply Out of Range | ECU has detected a GIO sensor power error. | <ul style="list-style-type: none"> - Verify connectors are correctly seated and have no signs of moisture or corrosion. - Check for signs of damage to the cable or connectors. - Verify good continuity for the GIO circuit. |
| 218 | 4 | GIO Components | Sensor Power Supply No Power | ECU has detected a GIO sensor power error (no power). | <ul style="list-style-type: none"> - Verify connectors are correctly seated and have no signs of moisture or corrosion. - Check for signs of damage to the cable or connectors. - Verify good continuity for the GIO circuit. |
| 218 | 12 | GIO Components | GIO Sensor Power Logic Failure | ECU has detected a failure of the GIO logic. | <ul style="list-style-type: none"> - Verify the ABS ECU power connector is seated correctly and has no signs of moisture or corrosion. - Verify correct power, ground at the main ABS ECU power connector and load test the power and ground circuit. |
| 219 | 2 | ABS ECU/Power Supply | J2497 Broadcast Breakdown | ECU cannot communicate on the J2497 PLC data bus. | <ul style="list-style-type: none"> - Verify the ABS ECU power connector is seated correctly and has no signs of moisture or corrosion. - Verify correct power, ground at the main ABS ECU power connector and load test the power and ground circuit. |
| 219 | 15 | ABS ECU/Power Supply | J2497 Failure | ECU cannot communicate on the J2497 PLC data bus. | <ul style="list-style-type: none"> - Verify the ABS ECU power connector is seated correctly and has no signs of moisture or corrosion. - Verify correct power, ground at the main ABS ECU power connector and load test the power and ground circuit. |
| 250 | 15 | ABS ECU/Power Supply | J1708 Failure | ECU cannot communicate on the J1708 data bus. | <ul style="list-style-type: none"> - Verify the ABS ECU power connector is seated correctly and has no signs of moisture or corrosion. - Verify correct power, ground at the main ABS ECU power connector and load test the power and ground circuit. |
| 251 | 1 | ABS ECU/Power Supply | Low Voltage Warning | ABS ECU has detected an under-voltage condition. | <ul style="list-style-type: none"> - Verify the ABS ECU power connector is seated correctly and has no signs of moisture or corrosion. - Verify correct power, ground at the main ABS ECU power connector and load test the power and ground circuit. - Verify output of towing vehicle voltage regulator. |

Diagnostics

| SID | FMI | Suspect Component and Location | Fault Description | Cause | Repair Information |
|-----|-----|--------------------------------|---|--|---|
| 251 | 3 | ABS ECU/Power Supply | High Voltage | ABS ECU has detected an over-voltage condition. | <ul style="list-style-type: none"> - Verify the ABS ECU power connector is seated correctly and has no signs of moisture or corrosion. - Verify correct power, ground at the main ABS ECU power connector and load test the power and ground circuit. - Verify output of towing vehicle voltage regulator. |
| 251 | 4 | ABS ECU/Power Supply | Low Voltage | ABS ECU has detected an under-voltage condition. | <ul style="list-style-type: none"> - Verify the ABS ECU power connector is seated correctly and has no signs of moisture or corrosion. - Verify correct power, ground at the main ABS ECU power connector and load test the power and ground circuit. - Verify output of towing vehicle voltage regulator. |
| 251 | 8 | ABS ECU/Power Supply | Intermittent Contact at Stop Light Power Supply | ABS ECU has detected an under-voltage condition. | <ul style="list-style-type: none"> - Verify the ABS ECU power connector is seated correctly and has no signs of moisture or corrosion. - Verify correct constant power, stop light power and ground at the main ABS ECU power connector and load test the power and ground circuit. |
| 251 | 10 | ABS ECU/Power Supply | Intermittent Contact at Constant Power Supply | ABS ECU has detected an under-voltage condition. | <ul style="list-style-type: none"> - Verify the ABS ECU power connector is seated correctly and has no signs of moisture or corrosion. - Verify correct power, ground at the main ABS ECU power connector and load test the power and ground circuit. - Verify output of towing vehicle voltage regulator. |
| 251 | 14 | ABS ECU/Power Supply | Power Supply Impedance Failure | ABS ECU has detected an internal error. | <ul style="list-style-type: none"> - Verify the ABS ECU power connector is seated correctly and has no signs of moisture or corrosion. - Verify correct power, ground at the main ABS ECU power connector and load test the power and ground circuit. |
| 253 | 2 | ABS ECU/Power Supply | Parameter Failure | ECU parameter error. | <ul style="list-style-type: none"> - Verify ABS ECU has correct configuration based on how many ABS sensors and modulator valves it is equipped with. - Reconfigure to correct system configuration using the WABCO TOOLBOX™ Software based on how many ABS sensors and modulators are used. |
| 253 | 12 | ABS ECU/Power Supply | Checksum/EEPROM Failure | ECU parameter error detected. | <ul style="list-style-type: none"> - Verify the ABS ECU power connector is seated correctly and has no signs of moisture or corrosion. - Verify correct power, ground at the main ABS ECU power connector and load test the power and ground circuit. |
| 253 | 13 | ABS ECU/Power Supply | GIO D4/D5 Parameter Failure | Internal error. | <ul style="list-style-type: none"> - Verify correct power, ground at the main ABS ECU power connector and load test the power and ground circuit. - Check communication between TOOLBOX and the ECU. - Verify correct GIO setup. |
| 253 | 14 | ABS ECU/Power Supply | Customer EOL Test Invalid | ECU parameter error detected. | <ul style="list-style-type: none"> - Verify correct power, ground at the main ABS ECU power connector and load test the power and ground circuit. - Check communication between TOOLBOX and the ECU. |

Diagnostics

| SID | FMI | Suspect Component and Location | Fault Description | Cause | Repair Information |
|-----|-----|--------------------------------|--------------------|---|---|
| 254 | 2 | ABS ECU/Power Supply | CPU Internal Error | ABS ECU has detected an internal error. | <ul style="list-style-type: none"> - Verify the ABS ECU power connector is seated correctly and has no signs of moisture or corrosion. - Verify correct power, ground at the main ABS ECU power connector and load test the power and ground circuit. |
| 254 | 12 | ABS ECU/Power Supply | CPU Hardware Error | ABS ECU has detected an internal error. | <ul style="list-style-type: none"> - Verify the ABS ECU power connector is seated correctly and has no signs of moisture or corrosion. - Verify correct power, ground at the main ABS ECU power connector and load test the power and ground circuit. |
| 254 | 15 | ABS ECU/Power Supply | CPU Internal Error | Internal short to controller. | <ul style="list-style-type: none"> - Verify the ABS ECU power connector is seated correctly and has no signs of moisture or corrosion. - Verify correct power, ground at the main ABS ECU power connector and load test the power and ground circuit. |

7 Component Replacement

Hazard Alert Messages

Read and observe all Warning and Caution hazard alert messages in this publication. They provide information that can help prevent serious personal injury, damage to components, or both.

WARNING

To prevent serious eye injury, always wear safe eye protection when you perform vehicle maintenance or service.

WARNING

Park the vehicle on a level surface. Block the wheels to prevent the vehicle from moving. Support the vehicle with safety stands. Do not work under a vehicle supported only by jacks. Jacks can slip and fall over. Serious personal injury can result.

WARNING

The ABS is an electrical system. When you work on the ABS, take the same precautions that you must take with any electrical system to avoid serious personal injury. As with any electrical system, the danger of electrical shock or sparks exists that can ignite flammable substances. You must always disconnect the battery ground cable before working on the electrical system.



Disconnect power from the ECU/Valve Assembly before you remove any components. Failure to disconnect power from the ECU can cause faults to be recorded and stored in ECU memory.

CAUTION

When welding on an ABS-equipped vehicle is necessary, disconnect the power connector from the ECU to avoid damage to the electrical system and ABS components. Description of a possible situation which may result in irreversible injury if the warning is ignored.

CAUTION

High voltages can damage the electronic control unit (ECU). Disconnect all connectors from the ECU before you perform any welding, electrostatic painting, or any other activity that applies high voltage to the vehicle frame. Install blind plugs into the ECU to protect the connector openings. Ground the welding or painting equipment to the part you are working on. If you are working on a moving or insulated component such as an axle, make sure it is correctly grounded through the frame. Refer to the equipment manufacturer's recommended instructions for correct procedures.

Component Replacement

7.1 Wheel Speed Sensor

7.1.1 How to Remove a Sensor

1. Follow the vehicle manufacturer's instructions to back off the slack adjuster and remove the tire, wheel and drum.
2. Hold the sensor, not the cable, and use a twisting motion to pull the sensor out of its mounting block.
3. Remove the spring clip from the mounting block.
4. Remove any fasteners that hold the sensor cable to other components.
5. Disconnect the sensor cable from the extension cable.

7.1.2 How to Install a Sensor

Sensor locations vary according to suspension types. Typically, a spring suspension has sensors on the forward axle, and an air suspension has sensors on the rear axle.

1. Apply a mineral oil-based grease that contains molydisulfide to the sensor spring clip and to the body of the sensor. The grease must be anti-corrosive and contain adhesive properties that will continuously endure temperatures from -40° to 300°F (-40° to 150°C).
2. Push the spring clip into the sensor holder from the inboard side, until the spring clip tabs are against the sensor holder. Push the sensor into the spring clip as far as possible.

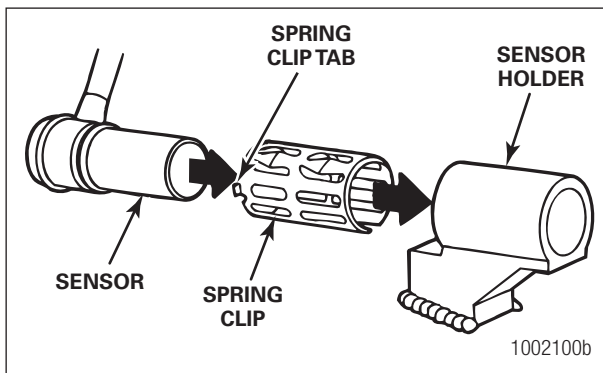

3. Route the sensor cable toward the brake chamber, over the brake spider, and behind the axle. Secure the cable to the axle between the brake spider and the suspension brackets. Continue to route the sensor cable behind the spring seats. Secure the cable to the axle 3 inches from the molded sensor plug.

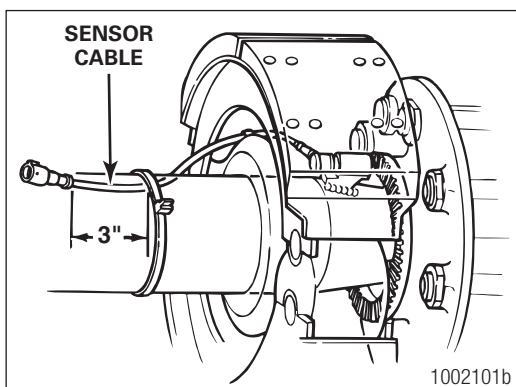

Component Replacement

4. Install the wheel hub carefully, so that the sensor pushes against the tooth wheel as you adjust the wheel bearings. After installation there should be no gap between the sensor and the tooth wheel. During normal operation a gap of 0.040-inch is allowable.
5. **Sensor Output Voltage Test:** Use a volt/ohm meter to check the AC output voltage of the sensors while rotating the wheel at approximately one-half revolution per second. Minimum output must be greater than 0.2 volts AC. If minimum output is less than 0.2 volts AC, push the sensor toward the tooth wheel. Recheck the sensor output.

7.2 ABS Relay Valve

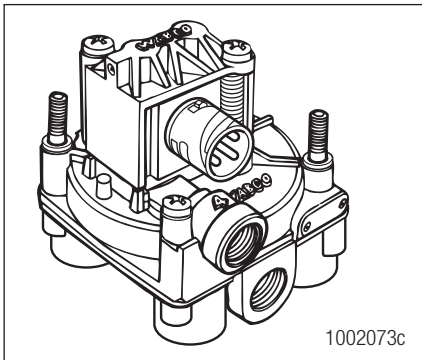

WARNING

Release all pressure from the air system before you disconnect any components. Pressurized air can cause serious personal injury.

7.2.1 How to Remove a Standard ABS Relay Valve

1. Release all pressure from the air system.
2. Disconnect the cable from the valve.
3. Attach labels to identify all of the air lines.
4. Disconnect the air lines from the valve.
5. Remove the mounting fasteners if the valve is not nipple-mounted directly to the air tank.
6. Remove the valve.

7.2.2 How to Install a Standard ABS Relay Valve

WARNING

You must use Schedule 80 pipe nipple (3/4-inch NPTF) to nipple-mount the ABS relay valve securely to the reinforced air tank to avoid possible serious personal injury and damage to components when tank mounting the ECU valve.

1. Install the valve with two lock nuts and washers as required. Tighten the hex nuts to a torque of 18 lb-ft (24 N•m) or nipple-mount the valve directly to the air tank with Schedule 80 pipe nipple (3/4-inch NPTF).
2. Connect the air lines to the ports according to the labels installed when the air lines were disconnected.

Component Replacement

3. Connect the cable to the valve.
4. Pressurize the brake system. Apply the brakes and verify there are no air leaks.

7.3 ECU/Valve Assembly

WARNING

Release all pressure from the air system before you disconnect any components. Pressurized air can cause serious personal injury.

7.3.1 How to Remove the ECU/Valve Assembly

1. Release all pressure from the air system.
2. Attach labels to identify all air lines.
3. Disconnect the air lines from the ECU/Valve Assembly.
4. Disconnect the power (or power/diagnostic) cable, additional relay valve cable (if used), and all sensor cables from the ECU/Valve Assembly.
5. Remove the ECU/Valve Assembly from its mounting location:
 - A. **Bracket-mounted:** Loosen and remove the two mounting bolts and lock nuts that hold the assembly to the cross member. Remove the assembly.
 - B. **Nipple-mounted to Air Tank:** Unscrew the assembly from the air tank.
6. If the assembly being replaced is under warranty, please return it to the trailer OEM for replacement.

7.3.2 How to Install the ECU/Valve Assembly

 The ECU/Valve Assembly is supplied with black protective caps on each sensor connector.

 When a sensor cable is not plugged into a sensor connector, the black cap must remain on the connector to protect it from dirt and contamination.

Component Replacement

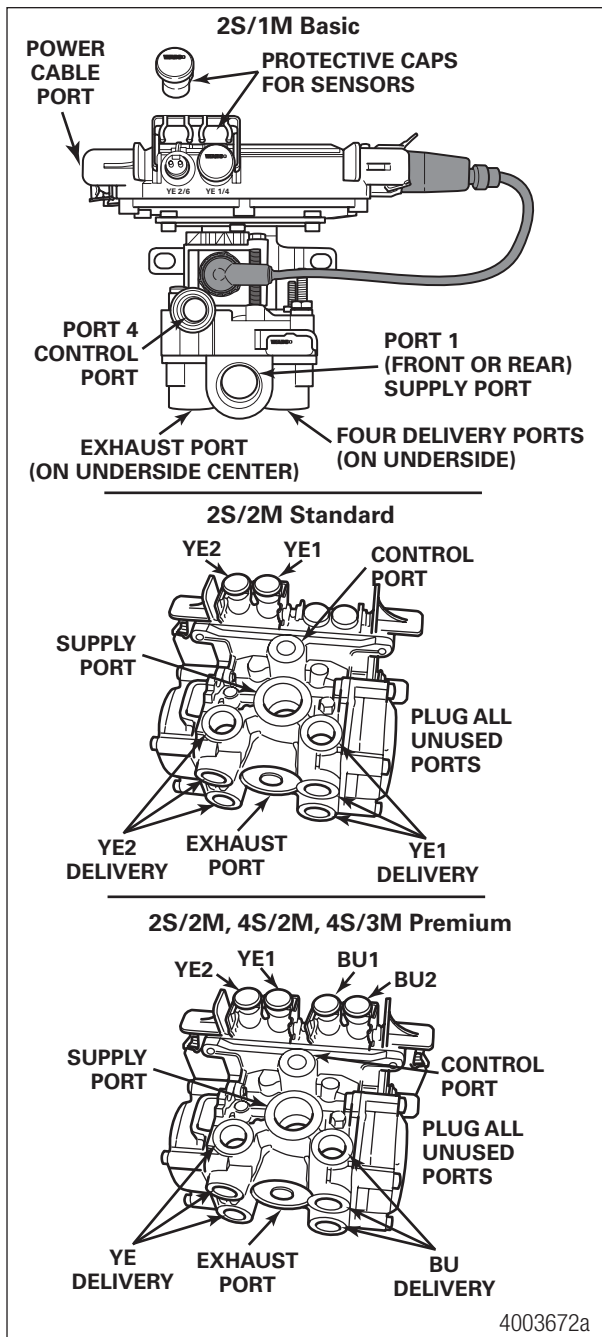

⚠ WARNING

You must use Schedule 80 pipe nipple (3/4-inch NPTF) to nipple mount the ECU/Valve Assembly securely to the air tank to avoid possible serious personal injury and damage to components.

Component Replacement

7.3.2.1 Tank-Mounted

⚠ WARNING

You must use Schedule 80 pipe nipple (3/4-inch NPTF) to mount the ECU/single modulator valve securely to the air tank to avoid possible serious personal injury and damage to the components.

1. Use a 3/4-inch Schedule 80 hex nipple to attach ECU/single modulator valve assembly to a reinforced air tank. Do not overtighten.



WABCO does not recommend use of a vise when installing the hex nipple. Use of a vise may cause overclamping. Overclamping may damage the internal components of the ECU/single modulator valve assembly.

2. Use a 3/4-inch pipe plug to plug unused supply port (Port 1). Apply SAE-standard, DOT-approved Teflon tape or paste-type thread sealant to all pipe threads beyond the first two threads. Pipes with pre-applied thread sealant may also be used.
3. Rotate and tighten the ECU/single modulator valve assembly until the exhaust port faces down and the connection is secure. Use a torque wrench or ratchet with extension at the 3/4-inch pipe plug installed on the front supply port (Port 1).

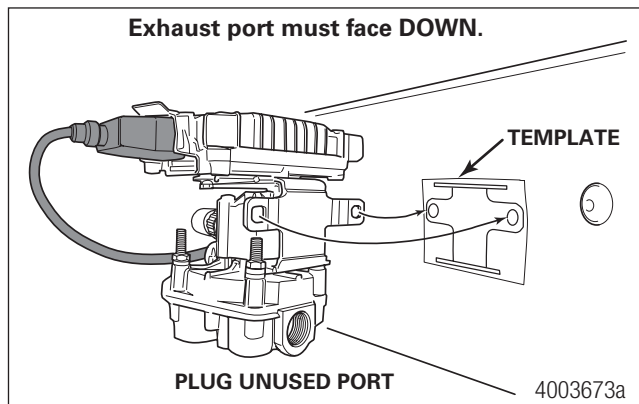

7.3.2.2 Bracket-Mounted to Cross Member of Vehicle (2S/1M Basic)

⚠ CAUTION

A barrier of plastic or mylar should be placed between the ECU/modulator valve and the surface it will be mounted on. This will help inhibit potential corrosion between dissimilar metals. Galvanic corrosion can result in damage to the ECU/modulator valve assembly.

1. Install a 3/4-inch NPTF fitting in supply port (Port 1). Use a 3/4-inch pipe plug to plug unused supply port (Port 1).
 - Use a 3/4-inch pipe plug to plug unused supply port (Port 1). Apply SAE-standard, DOT-approved Teflon tape or paste-type thread sealant to all pipe threads beyond the first two threads. Pipes with pre-applied thread sealant may also be used.
2. Attach mounting bracket to vehicle cross member midway between the side rails, close to the brake chambers the valve serves.
3. Use two 3/8-inch Grade 8 bolts with prevailing torque nuts and washers to attach assembly to the vehicle cross member. Tighten bolts to 18 lb-ft (24 N•m).

Component Replacement

7.3.2.3 Mounted to Cross Member of Vehicle — Standard and Premium Mounting Bracket Not Supplied

i When mounting the ECU/dual modulator valve assembly to the trailer cross member, refer to SAE specification J447, Prevention of Corrosion of Motor Vehicle Body and Chassis Components. Follow all recommendations and procedures. Your supervisor should have a copy of this specification.

⚠ CAUTION
A barrier of plastic or mylar should be placed between the ECU/modulator valve and the surface it will be mounted on. This will help inhibit potential corrosion between dissimilar metals. Galvanic corrosion can result in damage to the ECU/modulator valve assembly.

1. Install a 3/4-inch NPTF fitting in supply port. Use a 3/4-inch pipe plug to plug unused supply port (Port 1).
 - Apply SAE-standard, DOT-approved Teflon tape or paste-type thread sealant to all pipe plugs beyond the first two threads. Pipes with pre-applied thread sealant may also be used.

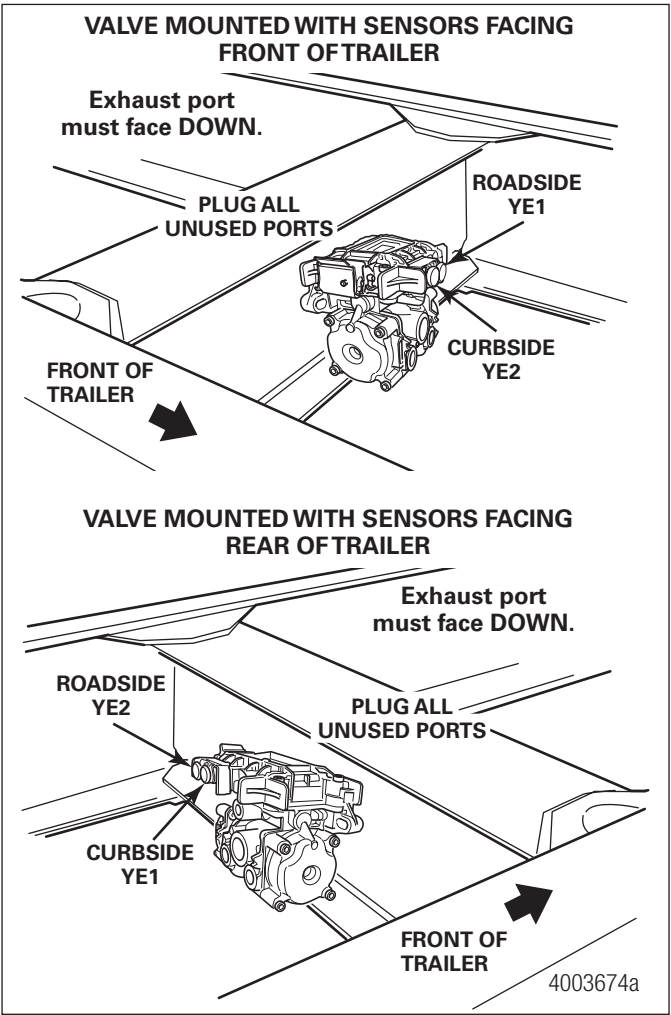

Component Replacement

2. Use two 3/8-inch Grade 8 bolts with prevailing torque nuts to attach assembly. Tighten bolts to 18 lb-ft (24 N•m).
3. Connect the air lines to the ports. Follow the label markers installed when the air lines were disconnected.
4. Connect the sensor cables, external relay valve cable (if used), and power or power/diagnostic cable to the ECU/Valve Assembly. Use the black protective connector caps included with the replacement assembly to cover unused cable connectors.
5. Perform End of Line Check before returning the trailer to service.

7.3.3 Replacing the ECU or Modulator Valve

With Enhanced Easy-Stop, the ECU and modulator valve may be replaced individually. To do this, follow the instructions for removing the complete assembly, then remove the valve from the ECU.



For 2S/1M installations where the valve is readily accessible, it may not be necessary to remove the entire assembly to replace the valve.



For 2S/1M bracket-mounted installations, the bracket does not need to be removed to replace the ECU or valve.

7.3.3.1 2S/1M Basic Only

To separate the ECU from the bracket, loosen and remove the three hex bolts from the underside of the bracket. These three hex bolts hold the assembly together.

Component Replacement

To separate the bracket from the valve, remove the three hex bolts.

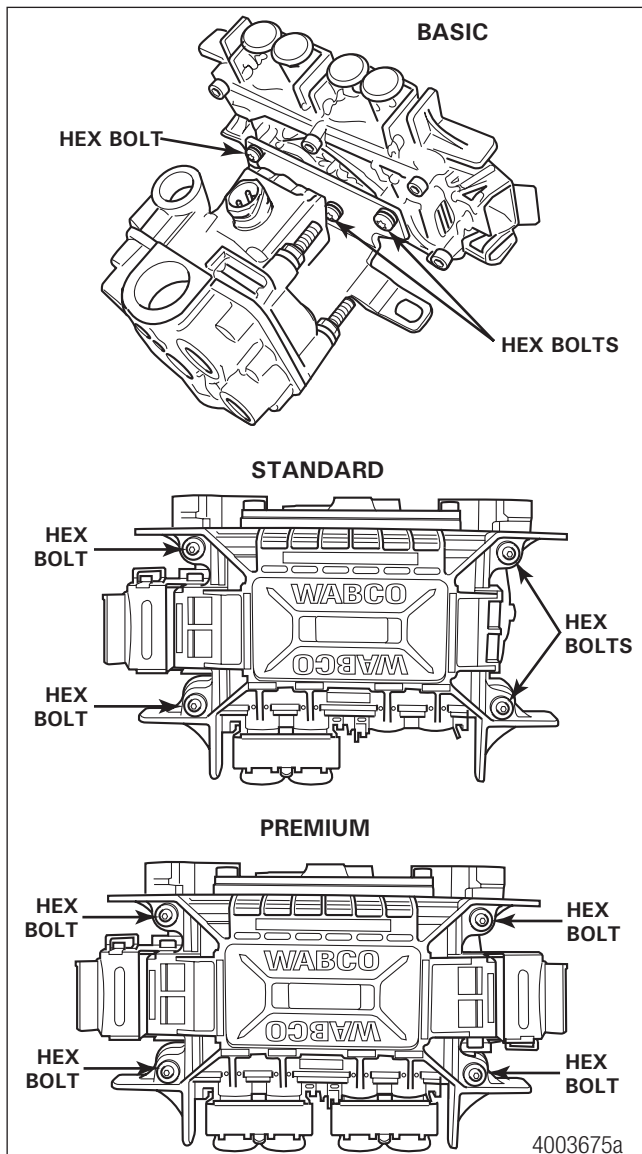

To attach the ECU to the bracket, tighten the three hex bolts to 6 lb-ft (8 N•m).

To attach the valve to the bracket, tighten the three hex bolts to 12 lb-ft (16 N•m).

7.3.3.2 All Standard and Premium Installations

Loosen and remove the four hex bolts holding the assembly together.

To attach the valve to the ECU, tighten the four hex bolts to 5 lb-ft (6 N•m).

Sensor Adjustment and Component Testing

8 Sensor Adjustment and Component Testing

8.1 How to Test Wheel Speed Sensors



At initial installation, no gap must exist between the sensor and the tooth wheel.



After you install a hub, always check that the sensor is adjusted correctly.

Operating the trailer can cause a gap to develop between the sensor and the tooth wheel. If the gap exceeds 0.040-inch, the system may not function correctly.

To adjust the sensor, twist and push the sensor through the sensor bracket as far as possible or until the sensor touches the tooth wheel.

8.1.1 Sensor Test Procedure

1. Disconnect power to the ECU/Valve Assembly.
2. Disconnect the sensor electrical connector from the ECU/Valve Assembly.
3. Connect the volt/ohm meter leads to the two wire component terminals inside the disconnected connector.
4. When checking the resistance, the meter must read 900-2000 ohms.
5. Check and replace the sensor and cables as required.
6. Repeat Steps 1-5 for each sensor in the system.

8.1.2 Sensor Output Voltage Test

1. Disconnect power from the ECU/Valve Assembly.
2. Connect the AC volt/ohm meter leads to the sensor terminals inside the connector.
3. Rotate the corresponding wheel at a constant speed of one-half revolution per second.
4. The output voltage must be greater than 0.2 volts AC.
5. When there is no reading:
 - a. Trace the cable to verify that the cable connects to the wheel you turned.
 - b. Check that you turned the correct wheel.
 - c. Check that the system is wired correctly.
 - d. Check that the sensor touches the tooth wheel.
5. If the volt/ohm meter still indicates no reading or a low reading after following the above procedures, check and replace the component and cables as required.
6. Repeat Steps 1-5 for each sensor in the system.

Sensor Adjustment and Component Testing

8.2 Check ABS Functions

- WABCO recommends that you test a vehicle's ABS after a new installation and after you diagnose, repair and erase faults in the ABS.
- Perform end of line check using TOOLBOX PLUS™ Software or the Pro-Link 9000.

8.3 ABS External Modulator Valve

Measure resistance across each valve solenoid coil terminal and ground on the ABS valve to ensure 4.0 to 8.0 ohms. Valve and cable pinouts are illustrated.

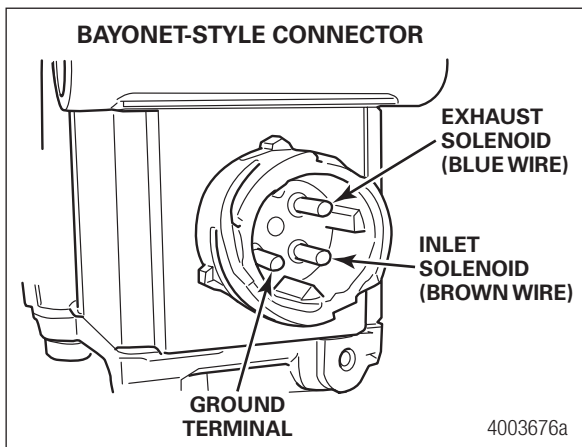

- To check the cable and the ABS valve as one unit, measure resistance across pins 5 and 6 and 5 and 7 on the ECU connector of the harness. Resistance should be between 4.0 and 8.0 ohms for each measurement.

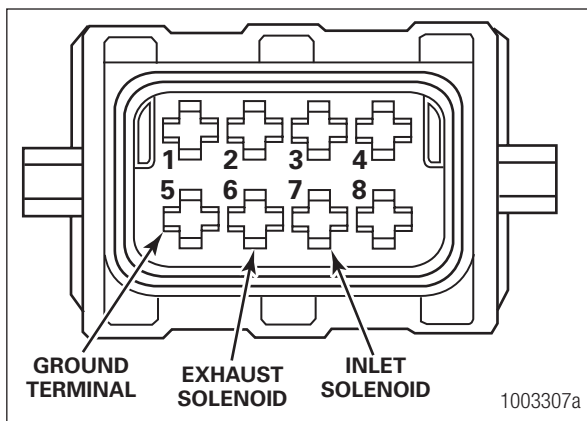

- If the resistance is greater than 8.0 ohms, clean the electrical contacts. Check the resistance again.

8.4 End of Line Testing

End of line testing is required on all Enhanced Easy-Stop installations. To run these tests, WABCO recommends you use TOOLBOX PLUS™ Software.

TOOLBOX PLUS™ Software and general test procedures are included in this manual. If you are using a Pro-Link, refer to the operating manual for test instructions.

Sensor Adjustment and Component Testing

8.4.1 End of Line Testing Procedure Using TOOLBOX PLUS™ Software (All Installations)

i If you are testing an installation that has a power only cable, temporarily install a WABCO combination power/diagnostics “Y” style cable or use the PLC/J1708 Adapter.

1. Connect the diagnostic connector on the cable to the PC serial port/SAE diagnostic interface (J1587/J1708 to RS232 interface).

i Refer to the Software Owner's Manual, TP99102, for instructions for running TOOLBOX PLUS™ Software.

2. Display the Trailer ABS Main Screen.
3. Verify power supply:
 - Apply 12 volts DC to the blue wire (constant). Check the screen for correct voltage (9.5 to 14 volts). Constant power voltage is displayed in the **Primary** field.
 - Apply 12 volts DC to the red wire (stoplight power). Check the screen for correct voltage (9.5 to 14 volts). Stoplight power voltage is displayed in the **Secondary** field.

i The internal field is not applicable to this test.

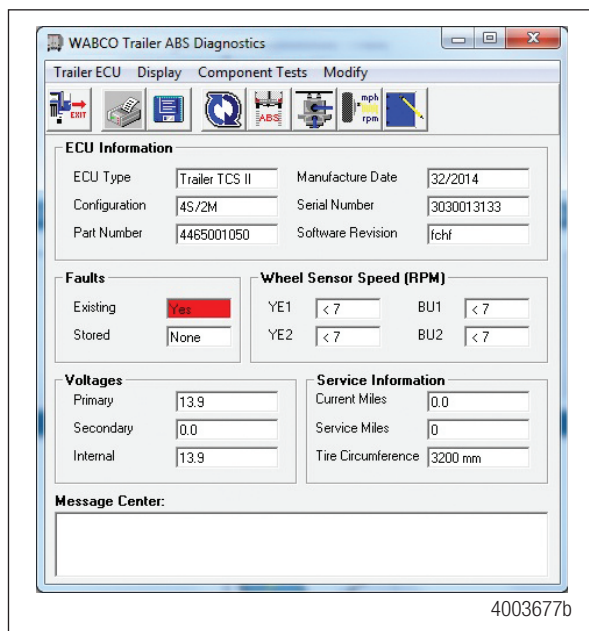

Sensor Adjustment and Component Testing

4. Check the Faults field on the Main Screen:
NONE = No faults present, proceed with end of line test.
YES = Faults present, double-click on “YES” to bring up the fault information screen.
Use the information in the **Repair Instructions** field to make the necessary repairs.

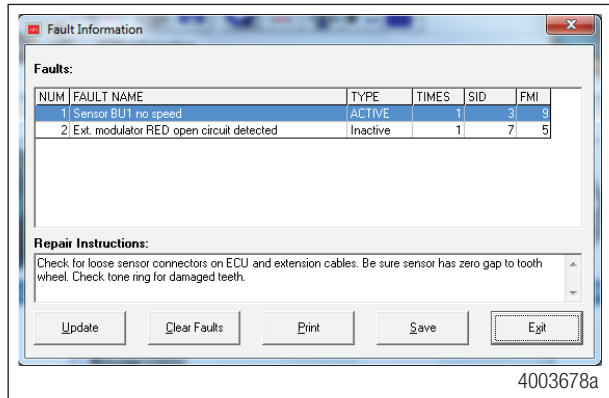

8.4.2 Verify Correct Valve and Lamp Installation (2S/1M Basic)

To verify valve and lamp installations with TOOLBOX PLUS™ Software:

1. At the Trailer Main Screen click on **Component Test**, then select **Valves/Lamp** to display the Valve Activation Screen.



2. The Red valve indicator will be selected. Click on the **Activate** button and listen for the valve to click, indicating a good installation. The Test Status box at the bottom of the menu will also display the status of this test.
3. Click on the **Test** button to activate the ABS indicator lamp — this is the lamp that is mounted on the side of the trailer. The lamp will flash eight times, indicating lamp installation is OK. The Test Status box at the bottom of the menu will also display the status of this test.
4. Click on **Close** to exit.

Sensor Adjustment and Component Testing

8.4.3 2S/2M, 4S/2M, 4S/3M (Standard and Premium)

To verify valve and lamp installations with TOOLBOX PLUS™ Software:

1. Apply 12 volts DC to the ABS.
2. Apply air to the emergency line to fill the air tanks and release the spring brakes.
3. Apply air to the control line.
4. At the Trailer Main Screen click on **Component Test**, then select **Valves/Lamp** to display the Valve Activation Screen. The Yellow valve indicator will be highlighted.



Selecting "All Valves" will sequence all of the valves beginning with the Yellow valve.



5. Click on the **Activate** button.
6. Check for correct air line installation. To do this, observe the slack adjusters:
 - If the ECU faces **the front of the trailer**, the slack adjusters will move in and out as the **curbside** portion of the dual modulator valve cycles. If this does not happen, the air lines are not correctly connected. Make the necessary repairs.
 - If the ECU faces **the rear of the trailer**, the slack adjusters will move in and out as the **roadside** portion of the dual modulator valve cycles. If this does not happen, the air lines are not correctly connected. Make the necessary repairs.



The Test Status box at the bottom of the menu will display the status of this test.

Sensor Adjustment and Component Testing

7. Repeat this test for the Blue valve.
 - A. Repeat Steps 1-3.
 - B. Select the Blue valve from the valve activation screen.
 - C. Click on the activate button to verify correct valve installation (Blue).
 - D. Check for correct air line installation. To do this, observe the slack adjusters.
 - If the ECU faces **the front of the trailer**, the slack adjusters will move in and out as the **roadside** portion of the dual modulator valve cycles. If this does not happen, the air lines are not correctly connected. Make the necessary repairs.
 - If the ECU faces **the rear of the trailer**, the slack adjusters will move in and out as the **curbside** portion of the dual modulator valve cycles. If this does not happen, the air lines are not correctly connected. Make the necessary repairs.
8. For 4S/3M installations: Repeat this test for the red valve.

Red: The external relay valve designated RED (RD) is an axle control valve. It controls brake chambers on one or two axles. It is important that delivery lines from port #2 are plumbed as shown on the installation drawings. The 4S/3M system is designed to be used with a variety of trailer configurations. Contact the WABCO Customer Care Center at 855-228-3203 for additional information.
9. Click on the **Test** button to activate the ABS indicator lamp — this is the lamp that is mounted on the side of the trailer. The lamp will flash eight times, indicating lamp installation is OK. The Test Status box at the bottom of the menu will display the status of this test.



10. Click on **Close** to exit.

8.4.4 Sensor Installation Test (All Installations)

To test the sensor installation:

1. Raise all sensed wheel ends off of the ground.
2. Apply air to the emergency line to fill the air tanks and release the spring brakes so that the wheels can be rotated.

Sensor Adjustment and Component Testing

3. Apply 12 volts DC to the ABS.
4. Apply 12 volts DC to the ABS.
5. At the Trailer Main Menu, click on **Component Test**, then select **Sensor Test** to display the Sensor Test screen.
6. Click on the **Start** button to start the test.
7. Rotate the sensed wheel ends at a rate of 1/2 revolution per second. This rate equals a wheel speed of approximately 4 mph (7 kph).
8. Check the screen for sensor output.

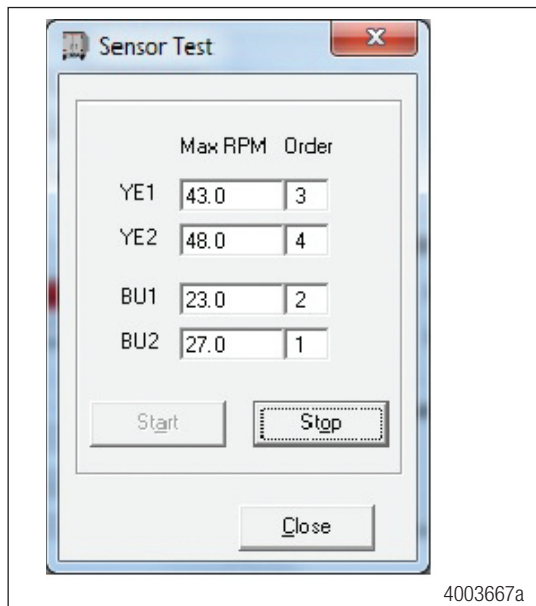

- Make sure there is sensor output. If sensor output is displayed, sensor test is complete.
 - If there is no sensor output, verify that a tone ring has been installed and that the sensor is pushed all the way in against the tone ring. Make the necessary repairs and repeat the sensor test. If the problem persists, contact the WABCO Customer Care Center.
9. Check **Order** fields to verify sensors were installed in the right location based on orientation of the valves.



Refer to the sensor locations in this section.

8.4.5 Sensor Orientation Test

This test is not for use on 4S/3M installations.

For **4S/3M installations**, use the standard Sensor Test. To run the standard test, select Sensor Test from the Components Test Menu.

The sensor orientation test must be performed as part of the end of line testing procedure.

Sensor Adjustment and Component Testing

8.4.5.1 Sensor Orientation Test Screen

Before beginning this test, look at the ECU to see if the sensors face the front or rear of the trailer. TOOLBOX PLUS™ 12.2 or higher will ask for this information to start the test (Step 5). To perform the sensor orientation test:

1. Raise the sensed wheel ends off the ground.
2. Apply air to the emergency line to fill the air tanks and release the spring brakes so that the wheels can be rotated.
3. Apply 12 volts DC to the ABS.
4. At the Trailer Main Menu, click on **Component Test**, then select **Sensor Orientation Test** to display the Sensor Orientation Test screen.

When the Sensor Orientation Test screen first appears, the Sensors Facing field will display the default — Front. This will occur regardless of the actual sensor orientation of the installation being tested.

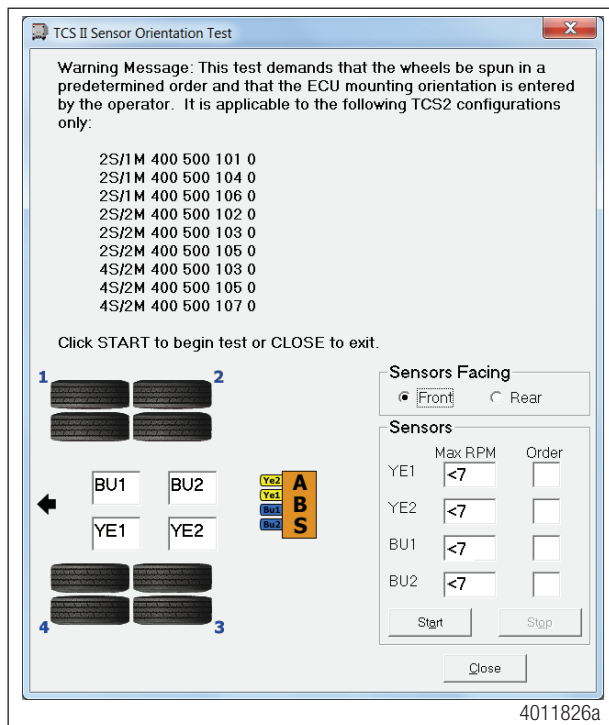

5. Click on **Front** or **Rear** in the Sensors Facing field to select the mounting orientation of the ECU/dual modulator valve assembly.

Sensor Adjustment and Component Testing

Refer to the illustrations of the ECU mounted with sensors facing forward and rear. The correct mounting orientation must be selected prior to starting the test (Step 6).

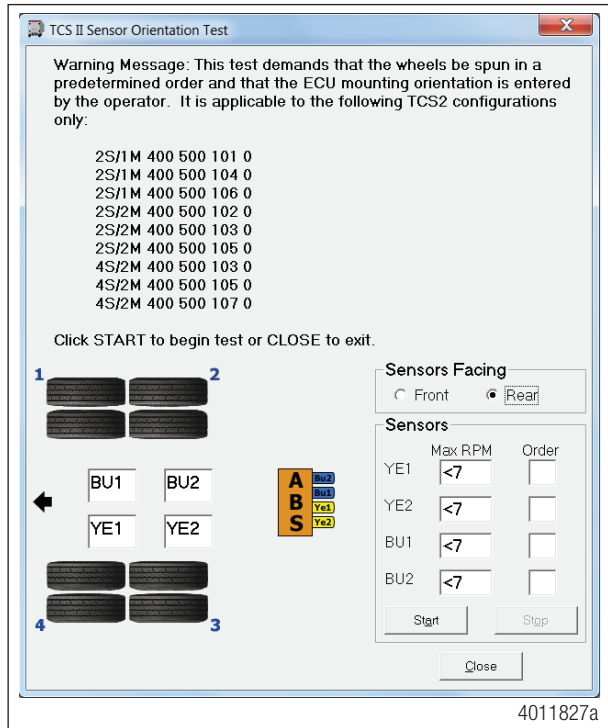

2S/2M installations use YE1 and BU1 locations.

6. Click on **Start** to begin the test.

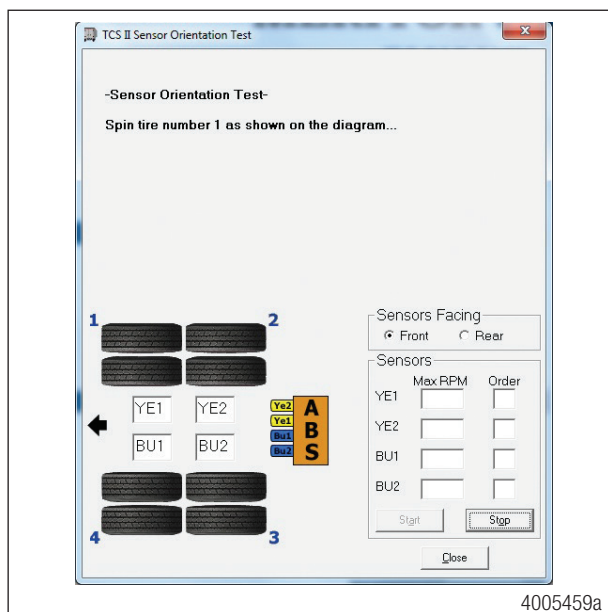

Sensor Adjustment and Component Testing

7. Follow the screen prompts, starting with wheel end 1, rotate each sensed wheel end at a rate of 1/2 revolution per second. This rate equals a wheel speed of approximately 4 mph (7 kph). As each sensed wheel is rotated, check the color of the sensor identification block on the screen for results. Sensor identification boxes are located in the bottom left portion of the Sensor Orientation Test screen.

Green background: Correct sensor location. Spin the next sensed wheel as indicated by the screen prompt.

Red background: Incorrect sensor location. If you get a red background, you must stop the test (click on stop), make the necessary corrections and repeat Steps 3 through 6.

8. To finish the Sensor Orientation Test, click on **Stop**, then on **Close**.



If there is no sensor output, verify that a tone ring has been installed and that the sensor is pushed all the way in against the tone ring. Perform the necessary repairs and repeat the test. If the problem persists, contact the WABCO Customer Care Center at 855-228-3203. Sensor output appears in the Sensors field located in the bottom right portion of the Sensor Orientation Test screen

If the problem persists, contact the WABCO Customer Care Center at 855-228-3203.

8.5 End of Line Testing without TOOLBOX PLUS™ Software 12.2 or Higher

8.5.1 2S/1M Basic

1. Apply 12 volts DC power to the ABS.
2. The ECU/single modulator valve assembly should click two times.
3. If the indicator lamp **comes on** for three seconds and **goes out**:
 - This indicates a correct installation. The end of line test is complete.
 - If the ABS indicator lamp **comes on** and **stays on**, check the sensor installation:
 - A. Remove the power from the ABS and raise the sensed wheels so they may be rotated.
 - B. Repeat Step 1 and Step 2.
 - C. Rotate each sensed wheel — one at a time — at a rate **less than 25 rpm**. The ABS indicator lamp should now go out and stay out indicating a correct installation. The end of line test is complete.
4. If the ABS lamp does not go out, there is a sensor gap problem or hardware fault. Adjust the sensor and, if necessary, perform a fault code check.

Sensor Adjustment and Component Testing

8.6 Inspect the Sensor and Air Line Installation (2S/2M Standard)

8.6.1 Sensor Installation

1. Look at the YE2 and YE1 sensor connectors on the ECU/dual modulator valve assembly. Make sure the connectors are routed to the correct wheel end location, as follows:
 - If the ECU/dual modulator valve assembly is mounted with sensors facing the front of the trailer:
 - Sensor YE2 must be routed to the curbside wheel end location
 - Sensor YE1 must be routed to the roadside wheel end location
 - If the ECU/dual modulator valve assembly is mounted with sensors facing the rear of the trailer:
 - Sensor YE2 must be routed to the roadside wheel end location
 - Sensor YE1 must be routed to the curbside wheel end location
2. If sensors are not correctly installed, make the necessary repairs.

8.6.2 Air Line Installation

1. Make sure all unused air ports are plugged and that the exhaust port is facing DOWN.
2. Look at the air line installation to make sure all air lines are correctly installed.
 - If the ECU/dual modulator valve assembly is mounted with the sensors facing the front of the trailer, the air lines for the three delivery ports located under the YE2 sensor connector must be routed to **curbside**; the air lines for the three delivery ports on the opposite side of the valve must be routed to roadside.

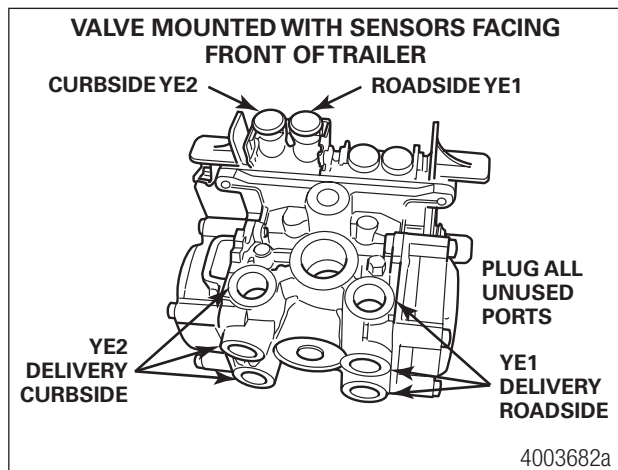

Sensor Adjustment and Component Testing

- If the ECU/dual modulator valve assembly is mounted with the sensors facing the rear of the trailer, the air lines for the three delivery ports located under the YE2 sensor connector must be routed to **roadside**; the air lines for the three delivery ports on the opposite side of the valve must be routed to curbside.

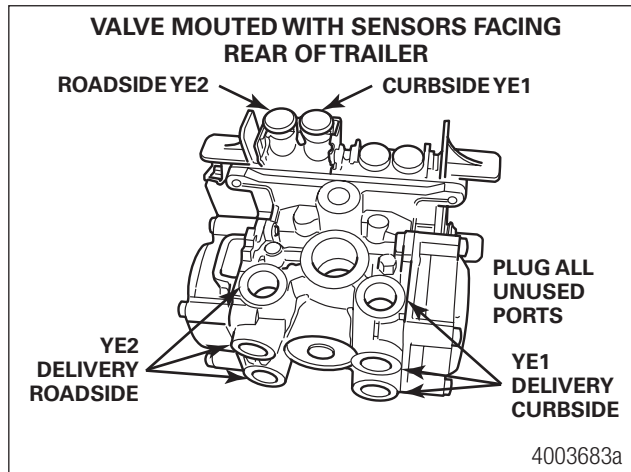

3. If air lines are not correctly routed, make the necessary repairs.

8.6.3 Inspect the Sensor and Air Line Installation (2S/2M, 4S/2M and 4S/3M Premium)

8.6.3.1 Sensor Installation

1. Look at the sensor connectors on the ECU/dual modulator valve assembly. Make sure the connectors are routed to the correct wheel end location, as follows:

ECU/Dual Modulator Valve Assembly Mounted with Sensors Facing Front of Trailer

- 2S/2M
 - Connect curbside sensor at YE1.
 - Connect roadside sensor at BU1.
- *4S/2M
 - Connect curbside front sensor at YE1.
 - Connect curbside rear sensor at YE2.
 - Connect roadside front sensor at BU1.
 - Connect roadside rear sensor at BU2.
- *4S/3M — Sensor locations vary by type of installation. Refer to diagrams for specific sensor locations
 - Connect curbside sensor at YE1.
 - Connect curbside sensor at YE2.
 - Connect roadside sensor at BU1.
 - Connect roadside sensor at BU2.

Sensor Adjustment and Component Testing

ECU/Dual Modulator Valve Assembly Mounted with Sensors Facing Rear of Trailer

- 2S/2M
 - Connect curbside sensor at BU1.
 - *4S/2M
 - Connect curbside front sensor at BU1.
 - Connect curbside rear sensor at BU2.
 - Connect roadside front sensor at YE1.
 - Connect roadside rear sensor at YE2.
 - *4S/3M — Sensor locations vary by type of installation. Refer to diagrams for specific sensor locations.
 - Connect curbside sensor at BU1.
 - Connect curbside sensor at BU2.
 - Connect roadside sensor at YE1.
 - Connect roadside sensor at YE2.
- * If the lift axle is sensed in 4S/2M and 4S/3M installations: Sensors YE2 and BU2 must always be used on the lift axle to avoid an unwanted ABS indicator lamp illumination.
2. If sensors are not correctly installed, make the necessary repairs.

8.6.3.2 Air Line Installation

1. Make sure all unused air ports are plugged and that the exhaust port is facing DOWN.
2. Look at the air line installation to make sure all air lines are correctly installed.
 - If the ECU/dual modulator valve assembly is mounted with the sensors facing the **front** of the trailer, the air lines for the three delivery ports located under the YE sensor connectors must be routed to **curbside**; the air lines for the three delivery ports on the opposite side of the valve must be routed to roadside.

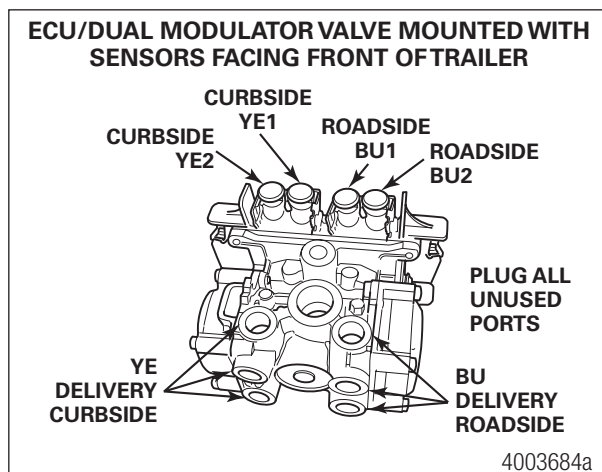

Sensor Adjustment and Component Testing

- If the ECU/dual modulator valve assembly is mounted with the sensors facing the **rear** of the trailer, the air lines for the three delivery ports located under the YE sensor connectors must be routed to **roadside**; the air lines for the three delivery ports on the opposite side of the valve must be routed to curbside.

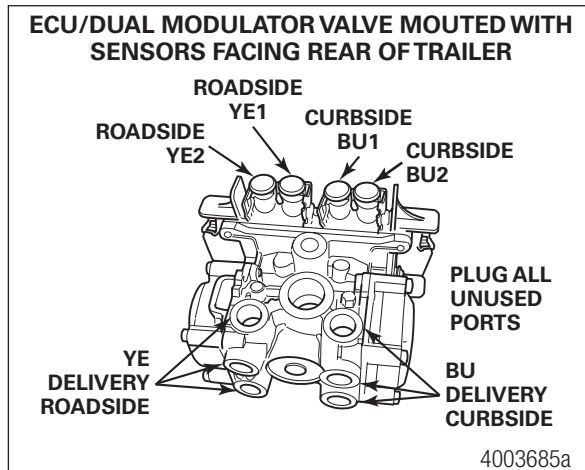

3. **For 4S/3M installations:** Repeat this test for the red valve.
 - Red: The external relay valve designated RED (RD) is an axle control valve. It controls brake chambers on one or two axles. It is important that delivery lines from port #2 are plumbed as shown on the installation drawings. (Refer to Figs. 5.8, 5.9 and 5.10.) The 4S/3M system is designed to be used with a variety of trailer configurations. Call the WABCO Customer Care Center at 855-228-3203 for additional information.
4. If air lines are not correctly routed, make the necessary repairs.

8.6.4 Perform End of Line Test (Standard and Premium Installations)

1. Apply 12 volts DC power to the ABS.
2. The ECU/dual modulator valve assembly should click four times (six times for a 4S/3M).
3. If the indicator lamp **comes on** for three seconds then **goes out**, this indicates a correct installation. The end of line test is complete.

If the ABS indicator lamp **comes on** and **stays on**, check the sensor installation:

- a. Remove the power from the ABS and raise the sensed wheels so they may be rotated.
 - b. Apply emergency air to fill the air tanks and release the spring brakes so that the wheels may be rotated.
 - c. Repeat Step 1 and Step 2.
 - d. Rotate each sensed wheel — one at a time — at a rate of **less than 25 rpm**. The ABS indicator lamp should now go out and stay out indicating a correct installation.
 - e. The end of line test is complete.
4. If the ABS lamp does not go out, there is a sensor gap problem or hardware fault. Adjust the sensor and, if necessary, perform a fault code check.

Sensor Adjustment and Component Testing

8.6.4.1 Sensor Gap Adjustment (All Installations)

Push sensor into its holder until it contacts the tooth wheel. At installation, there must be no gap between the sensor and the tooth wheel.

Measure the AC voltage output. Value should be 0.2 volt AC when wheel is rotated at a rate of 1/2 revolution per second.

8.6.4.2 Fault Code Check (All Installations)

Use constant power activation to perform the fault code check, as follows:

1. Apply constant power to the ECU/dual modulator valve assembly **for more than one, but less than five seconds**.
2. Remove power.
3. Reapply power.
4. Check the trailer ABS indicator lamp on the side of the trailer. The fault code will be displayed three times.
5. Find the fault on the table and make the necessary repairs.
6. After making the necessary corrections, repeat the end of line test.

Blink Code Table

| Blink Code | Problem Area | Action |
|------------|--|---|
| 3 | Sensor BU1 | Determine sensor location. Check sensor installation. Make necessary repairs. |
| 4 | Sensor YE1 | Determine sensor location. Check sensor installation. Perform necessary repairs. |
| 5 | Sensor BU2 | Determine sensor location. Check sensor installation. Make necessary repairs. |
| 6 | Sensor YE2 | Determine sensor location. Check sensor installation. Perform necessary repairs. |
| 7 | External ABS modulator valve | Verify correct electrical installation. Check power supply. Make necessary corrections. |
| 8 | Service interval notification | Indication that designated service mileage has elapsed. |
| 9 | Internal modulator failure, inlet valve #2 | Verify correct installation. If code continues, contact WABCO for assistance. |
| 10 | Internal modulator failure, inlet valve #1 | Verify correct installation. If code continues, contact WABCO for assistance. |
| 11 | Internal modulator failure, outlet valve | Verify correct installation. If code continues, contact WABCO for assistance. |
| 14 | Power Supply | Verify correct electrical installation. Check power supply. Make necessary corrections. |
| 15 | ECU Failure | Verify correct installation. If code continues, contact WABCO for assistance. |
| 16 | SAE J1708 Failure | Internal failure, contact WABCO. |

Sensor Adjustment and Component Testing

| Blink Code | Problem Area | Action |
|------------|-------------------------|---|
| 17 | SAE J2497 (PLC) Failure | Internal failure, contact WABCO. |
| 18 | Generic I/O Failure | Verify correct electrical installation. Check power supply. Make necessary corrections. |

8.7 Trailer Identification

An Enhanced Easy-Stop Trailer ABS warning label is generally affixed to the trailer near the ABS trailer indicator lamp.

If this label is not on the trailer, let your supervisor know. Labels are available from WABCO. Ask for Part Number TP95172.

For additional assistance, contact the WABCO Customer Care Center at 855-228-3203.

Before calling the WABCO Customer Care Center, be prepared to provide the following information about the trailer you are working on:

1. Trailer make and model year.
2. What is the symptom/complaint? What is the component doing or not doing?
3. What is the ABS blink code, MPSI Pro-Link 9000 reading or SID/FMI code?
4. Have any resistance and/or voltage measurements been taken?
5. What is the result of visual inspection of connectors, harness and components?
6. When does the symptom occur (vehicle moving, compressor unloading, etc.)?
7. Does the trailer have any unusual characteristics (for example, mismatched tires or larger than normal air consumption)?
8. Were maintenance manuals available? If so, which ones were used?
9. What is the part number of the ECU/Valve Assembly? What is the system configuration?

By having the above information ready when you call, your customer service technician will be better equipped to assist you.

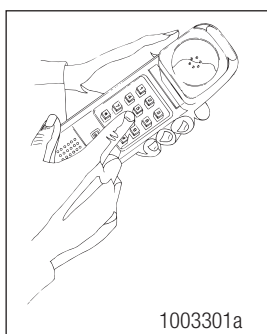

WABCO Customer Care Center, 855-228-3203

Troubleshooting

9 Troubleshooting

Hazard Alert Messages

Read and observe all Warning and Caution hazard alert messages in this publication. They provide information that can help prevent serious personal injury, damage to components, or both.

WARNING

To prevent serious eye injury, always wear safe eye protection when you perform vehicle maintenance or service.

WARNING

Remove all pressure from the air system before you disconnect any component. Pressurized air can cause serious personal injury.

WARNING

Park the vehicle on a level surface. Block the wheels to prevent the vehicle from moving. Support the vehicle with safety stands. Do not work under a vehicle supported only by jacks. Jacks can slip and fall over. Serious personal injury and damage to components can result.

WARNING

Ensure the trailer has correct electrical grounding; refer to SAE Specification J1908.

WARNING

When you work on an electrical system, the possibility of electrical shock exists, and sparks can ignite flammable substances. You must always disconnect the battery ground cable before you work on an electrical system to prevent serious personal injury and damage to components.

9.1 Lift Axle Troubleshooting

ECUs 400 500 105 0 and 400 500 106 0 are the only trailer ABS valves that have automatic lift axle functionality.

The first step taken when troubleshooting the Lift Axle system is to ensure that the system is pneumatically plumbed and electrically connected correctly. Refer to Figures 9.9, 9.10, 9.11, 9.12, 9.15 and 9.16 in this section for the correct schematic, depending upon the configuration

For additional information, refer to TP08103, Lift Axle Installation Manual, available at zf.com/cvliterature.

When testing the Lift Axle system, ensure the trailer is supplied with a minimum of 100 psi air pressure to the supply air and 12 volts DC power rated at a minimum of 10 amps to the trailer's constant power circuit.

Use of a volt-ohm meter may be required. A lift axle test rig may be built by the maintenance shop to facilitate the testing of the lift axle system. See Figure 9.12.

The ability to raise the trailer's fixed axles in order to conduct an end of line test may be required.

TIO files enable additional functionality, such as automatic lift axle, for the InfoLink capable ECUs. If a TIO file needs to be removed or replaced, contact the WABCO Customer Care Center at 855-228-3203.

This troubleshooting section is based on the use of TOOLBOX PLUS™ Software version 12.2 or higher. If you have an earlier version of software, visit <https://wabco.snapon.com/> or contact your Snap-On dealer.

Troubleshooting

| Condition Experienced | Action to Take | Troubleshooting Details |
|--|---|---|
| Lift Axle Function Unavailable in TOOLBOX PLUS™ Software | Inspect ABS ECU. | Ensure that GIO-capable WABCO iABS is installed. Only 400 500 350 0 and 400 500 430 0 have Axle Load Monitoring functionality. |
| | Verify the TOOLBOX PLUS™ Software version. | Ensure TOOLBOX PLUS™ software version 12.2 or higher is installed. |
| Lift Axle Will Not Raise or Lower | Recycle trailer power. | The ECU valve should audibly click during its power-up self-test. If the ECU fails to click, ensure that the sensor extension cables are securely attached to the ECU and ensure that 12 volts is present at pin A-3 on the ECU power connector. Refer to Fig. 9.1. |
| | Retrieve diagnostic information via TOOLBOX PLUS™ Software version 12.2 or higher. | When the trailer power is cycled, the trailer-mounted ABS warning light will illuminate and extinguish as a light test. If warning light remains on, begin diagnostics with TOOLBOX PLUS™ Software. Repair and clear all faults found. |
| | Check the Notebook feature in TOOLBOX PLUS™ Software to determine if lift axle function has been enabled. | Service information will display raise and lower pressures if the lift axle function is active. |
| | Verify the lift axle function is activated in TOOLBOX PLUS™ Software. | From the main TOOLBOX screen, select the Modify pull-down. Select Lift Axle Raise/Lower Pressures and active settings will be displayed. Input values if needed and save to ECU. |
| | Inspect lift axle control valve (LACV) cable 449 518 030 0. | Ensure the LACV cable 449 518 030 0 is securely fastened to the LACV and to the “D2” lead of the multiple I/O cable 449 442 010 0. |
| | Inspect multiple I/O cable 449 442 010 0. | Ensure the multiple I/O cable 449 442 010 0 is securely fastened to the ECU and that the “D2” lead is connected to the LACV cable 449 518 050 0. |
| | Check lift axle control valve cable integrity. | Using a volt/ohm meter, check for shorted or open circuits on LACV cable 449 518 030 0. Refer to Fig. 9.2. |
| | Check multiple I/O cable integrity. | Using a volt/ohm meter, check for shorted or open circuits on lead “D2” of the multiple I/O cable 449 442 010 0. Refer to Fig. 9.3. |
| | Inspect the lift axle control valve 463 084 050 0. | Ensure the LACV cable is securely fastened to the valve. |
| | Check the coil of the lift axle control valve. | Using an ohm meter, check the resistance between pins 1 and 4 and pins 1 and 2. The resistance should be 19 ohms (+/- 2 ohms at room temperature). Resistance between pins 2 and 4 should be less than 1 ohm. Refer to Fig. 9.4. |

Troubleshooting

| Condition Experienced | Action to Take | Troubleshooting Details |
|--|---|--|
| | Test the pressure switch 431 700 002 0. | Refer to Fig. 9.5 for the connector diagram of Pressure Switch 431 700 002 0. Use regulated shop air and an ohm meter to check the functionality of the switch. With greater than 70 psi (but less than 120 psi) applied to the switch, pins 1 and 2 resistance reading should show infinity. With less than 70 psi applied to the switch, pins 1 and 2 resistance reading should show less than 1 ohm. |
| | Test the pressure sensor 441 044 106 0. | Refer to Fig. 9.15 for the construction of a Lift Axle Test Rig. Attach regulated shop air to the pneumatic connector of pressure switch 441 044 106 0. Increase pressure so that it exceeds the parameterized lower axle threshold and the axle should deploy. Decrease pressure so that it drops below the parameterized threshold to raise the axle and the axle should rise. Replace the Pressure Sensor if axle fails to rise or lower. |
| | Check “Y” cable integrity (if applicable). | Using a volt/ohm meter, check for a shorted or open circuit on the lift axle “Y” cable 894 601 100 0. Refer to Fig. 9.8. |
| Lift Axle with Automatic Override Will Not Lower When Trailer is Parked; Trailer Has Power and Air Applied | Using TOOLBOX PLUS™ Software, ensure there are no active faults. | Repair and clear all active faults. Cycle the ECU power. |
| | Inspect pressure switch 431 700 002 0 installation. | Ensure pressure switch is plumbed into the delivery line to the spring brake. Refer to Figs. 9.9 through 9.14. |
| | Inspect the connection of pressure switch 431 700 002 0. | Ensure the pressure switch is correctly connected to the “A1” lead of the multiple I/O cable 449 442 010 0. |
| | Test the pressure switch 431 700 002 0. | Refer to Fig. 9.5 for the connector diagram of pressure switch 431 700 002 0. Use regulated shop air and an ohm meter to check the functionality of the switch. With greater than 70 psi applied to the switch, pins 1 and 2 resistance reading should show infinity. With less than 70 psi applied to the switch, pins 1 and 2 resistance reading should show less than 1 ohm. |
| | Check “Y” cable integrity (if applicable). | Using a volt/ohm meter, check for shorted or open circuits on ABS “Y” cable 894 601 100 0. Refer to Fig. 9.8. |
| | Check multiple I/O cable integrity. | Using a volt/ohm meter, check for a shorted or open circuit on the “A1” lead of multiple I/O cable 449 442 010 0. Refer to Fig. 9.3. |
| Lift Axle Will Not Lower When Trailer Is Unpowered | Inspect the pneumatic connections at the lift axle control valve 463 084 050 0. | Refer to Figs. 9.9 through 9.14 for the plumbing schematics, depending on system configuration. |
| Lift Axle Raises When Trailer is Moving | ECU was programmed with an out-of-date version of TOOLBOX PLUS™ Software. | Reprogram ECU with TOOLBOX PLUS™ Software version 12.2 or higher. |

Troubleshooting

| Condition Experienced | Action to Take | Troubleshooting Details |
|---|--|--|
| Lift Axle Lowers Only When Tractor Brakes are Applied | Verify power to the ECU. | Ensure the trailer has blue center pin power at the J560 connector at the front of the trailer. Inspect the towing vehicle's power output to the J560. Ensure the J560 is wired correctly to the trailer OEM's specifications. Refer to Fig. 9.16. |
| | Check power cable throughput. | Ensure 12 volts DC power is present at pin A-3 on power cable 449 326 010 0. Refer to Fig. 9.1. |
| | Check power cable throughput. | Ensure 12 volts DC power is present to pin B-B at the power cable 449 326 010 0 from the ABS breakout of the trailer power cable. Refer to Fig. 9.1. |
| | Inspect trailer power/light cable. | Using a volt/ohm meter, check for shorted or open circuits on the trailer power/light cable from the J560 connector at the trailer nose to the ABS breakout pigtail. Continuity should be found between pin 7 on the J560 and the pin mating with pin B-B on the ABS power cable. Refer to Figs. 9.1 and 9.16. |
| Manual Override Switch Does Not Function | Inspect the manual override switch and 12v analog input cable 449 428 030 0. | Ensure the lift axle control valve is functional by disconnecting the LACV cable from the LACV. The axle should lower. |
| | Verify toggle switch operation. | Ensure the toggle switch is functional using an ohm meter. Switch output should show infinity ohms when the switch is in the OFF position and less than 1 ohm when the switch is in the ON position. |
| | Verify correct wiring of toggle switch. | Ensure that the yellow/green wire from the 12v analog input cable 449 428 030 0 is capped and unused. The blue and brown wires are attached to the toggle switch's contacts. Refer to Fig. 9.9 or 9.11. |
| | Check "Y" cable integrity (if applicable). | Using a volt/ohm meter, check for shorted or open circuits on ABS "Y" cable 894 601 100 0. Refer to Fig. 9.8. |
| | Check analog input cable integrity. | Using a volt/ohm meter, check for shorted or open circuits on 12v analog input cable 449 428 030 0. Refer to Fig. 9.6. |
| | Check multiple I/O cable integrity. | Using a volt/ohm meter, check for a shorted or open circuit on the "A1" lead of multiple I/O cable 449 442 010 0. Refer to Fig. 9.3. |
| Lift Axle Lowers When Powered Trailer Stops Moving | Verify override switch functionality. | Ensure the manual override toggle switch is not intermittently functional by checking with an ohm meter. Switch output should show infinity ohms when the switch is in the OFF position and less than 1 ohm when the switch is in the ON position. Induce vibration to the switch and switch wiring when checking switch activation. |
| | Inspect toggle switch installation. | Ensure wires connected to the switch are secure and not damaged. |

Troubleshooting

| Condition Experienced | Action to Take | Troubleshooting Details |
|---|---|---|
| | Inspect pneumatic component installation. | Ensure pressure switch 431 700 002 0 is plumbed correctly. Refer to Figs. 9.9 through 9.14 for the plumbing schematics, depending on system configuration. |
| | Inspect pneumatic component installation. | Ensure pressure sensor 441 044 106 0 is plumbed correctly. Refer to Figs. 9.9 through 9.14 for the plumbing schematics, depending on system configuration. |
| | Ensure correct ECU parameter file. | Reprogram ECU with TOOLBOX PLUS™ Software 12.2 or higher. |
| | Check multiple I/O cable integrity. | Using a volt/ohm meter, check for a shorted or open circuit on the “A1” lead of the multiple I/O cable 449 442 010 0. Refer to Fig. 9.3. |
| | Check analog input cable integrity. | Using a volt/ohm meter, check for a shorted or open circuit on the analog input cable 449 428 030 0. Refer to Fig. 9.6. |
| | Check “Y” cable integrity (if applicable). | Using a volt/ohm meter, check for a shorted or open circuit on the lift axle “Y” cable 894 601 100 0. Refer to Fig. 9.8. |
| Lift Axle Lowers and/or Raises at Values Inconsistent With Values in the ECU Parameter Settings | Inspect pressure sensor 441 044 106 0 installation. | Ensure that there are no air leaks in the air circuit where pressure sensor 441 044 106 0 is attached. |
| | Inspect lift axle control valve 463 084 050 0 installation. | Ensure that there are no air leaks in the air circuit where lift Axle control valve 463 084 050 0 is attached. |
| | Inspect system wiring. | Ensure the system is wired correctly. Refer to Figs. 9.9 through 9.14 depending on the system configuration. |
| | Ensure correct ECU parameter file. | Reprogram ECU with TOOLBOX PLUS™ Software version 12.2 or higher. |
| | Repair if no issues discovered from steps above. | Replace pressure sensor 441 044 106 0. |
| Optional Lift Axle Indicator Lamp Does Not Illuminate | Inspect LED lamp assembly. | Ensure the load-resistored LED or incandescent lamp is functional. |
| | Inspect LED lamp assembly. | Ensure load-resistored LED or incandescent lamp is wired correctly. Ensure the brown wire is connected to ground and the black wire is connected to power. |
| | Verify ECU voltage output. | A reading of 3 volts DC should be read across the two pins on “D3” of the light output cable 449 711 030 0 when the light is not illuminated (lift axle down). A reading of 12v DC should be read across the two pins on “D3” of the light output cable 449 711 030 0 when the light is illuminated (lift axle up). |

Troubleshooting

| Condition Experienced | Action to Take | Troubleshooting Details |
|--|---|---|
| Optional Lift Axle LED Indicator Lamp Stays on Faintly | Inspect indicator lamp and cable. | If damaged, replace the LED lamp with a load-resistored LED or incandescent lamp. |
| | Inspect indicator light wiring. | Ensure the load-resistored LED lamp is wired correctly. Make sure the brown wire is connected to ground and the black wire hooked to power. |
| | Inspect indicator light. | When using an LED lamp, ensure the LED assembly has a 1k ohm load resistor. When using an incandescent light, ensure that a 12v light is being used. |
| | Check light output cable integrity. | Using a volt/ohm meter, check for a shorted or open circuit on light output cable 449 711 030 0. Refer to Fig. 9.7. |
| Pressure Switch Test | Check pressure switch 431 700 002 0 functionality. | Refer to Fig. 9.5 for the connector diagram of pressure switch 431 700 002 0. Use regulated shop air and an ohm meter to check the functionality of the switch. With greater than 70 psi (and less than 100 psi) applied to the switch, pins 1 and 2 resistance reading should show infinity. With less than 70 psi applied to the switch, pins 1 and 2 resistance reading should show less than 1 ohm. |
| Pressure Sensor Test | Test the pressure sensor 441 044 106 0 functionality. | Refer to Fig. 9.13 for the construction of a Lift Axle Test Rig. Attach regulated shop air to the pneumatic connector of pressure switch 441 044 106 0. Increase pressure so that it exceeds the parameterized lower axle threshold and the axle should deploy. Decrease pressure so that it drops below the parameterized threshold to raise the axle and the axle should rise. |

Fig. 9.1

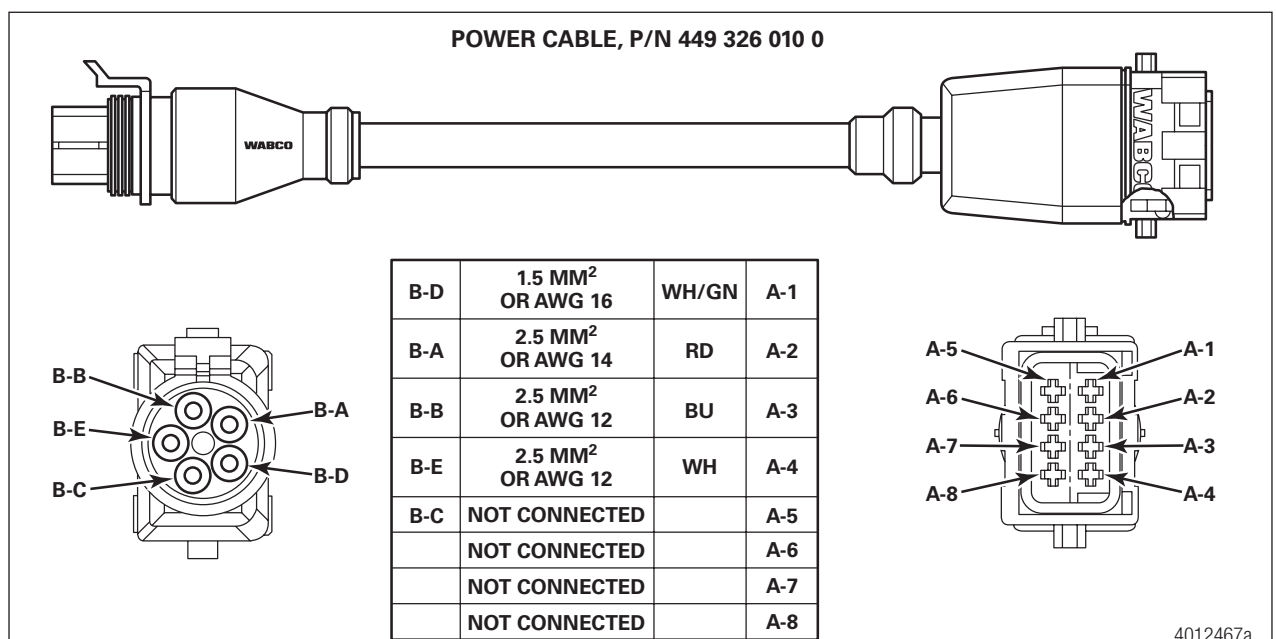

4012467a

Troubleshooting

Fig. 9.2

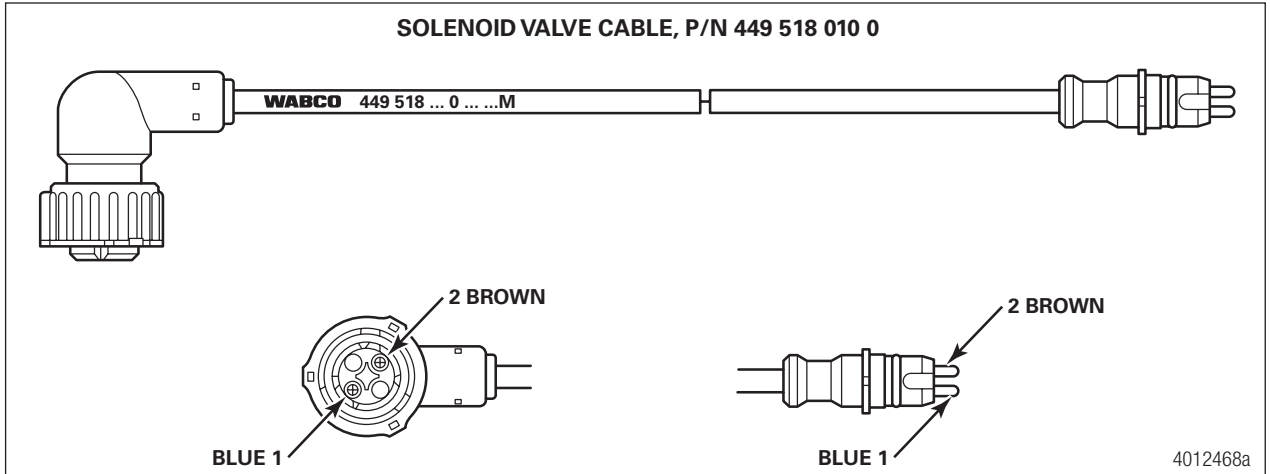
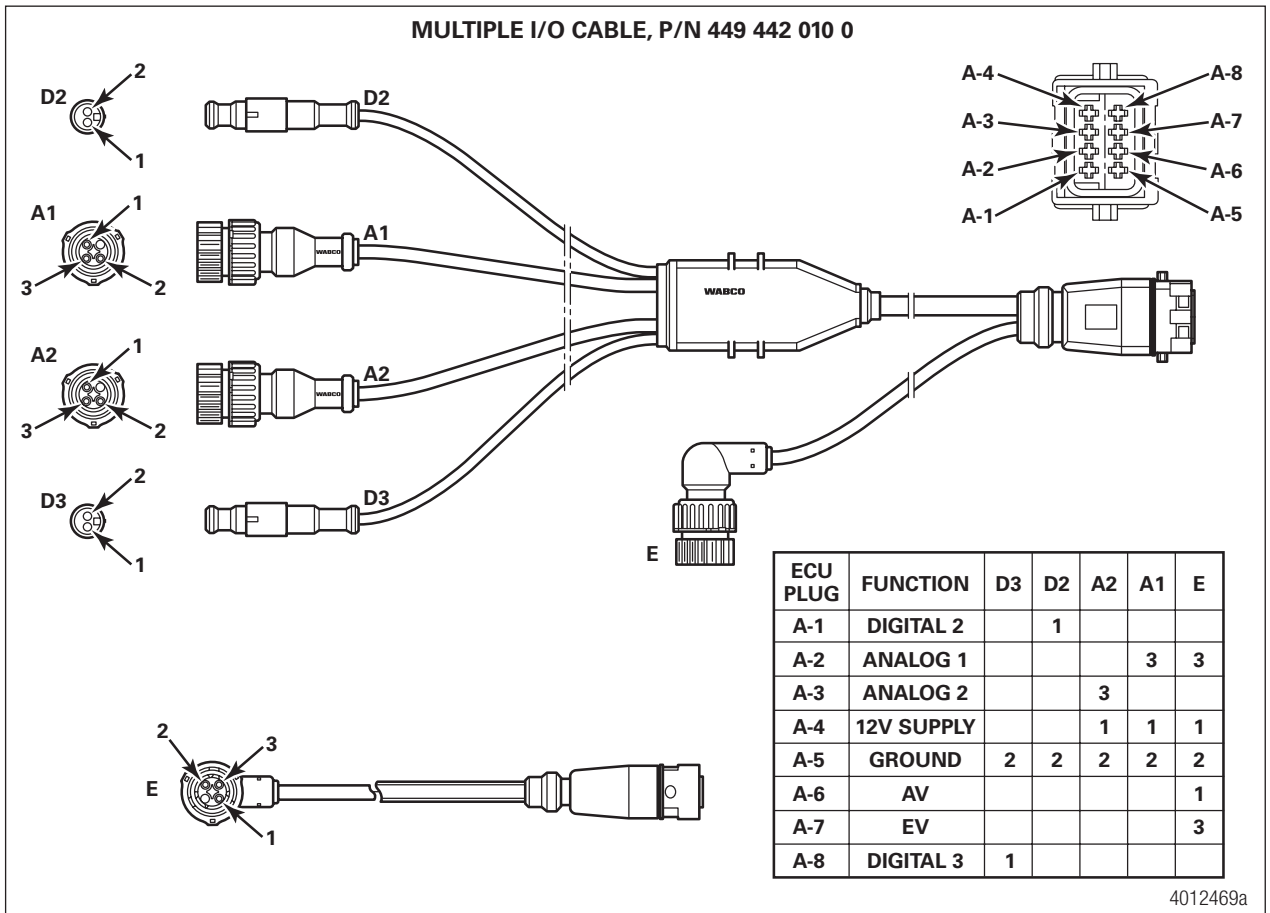

Fig. 9.3



Troubleshooting

Fig. 9.4

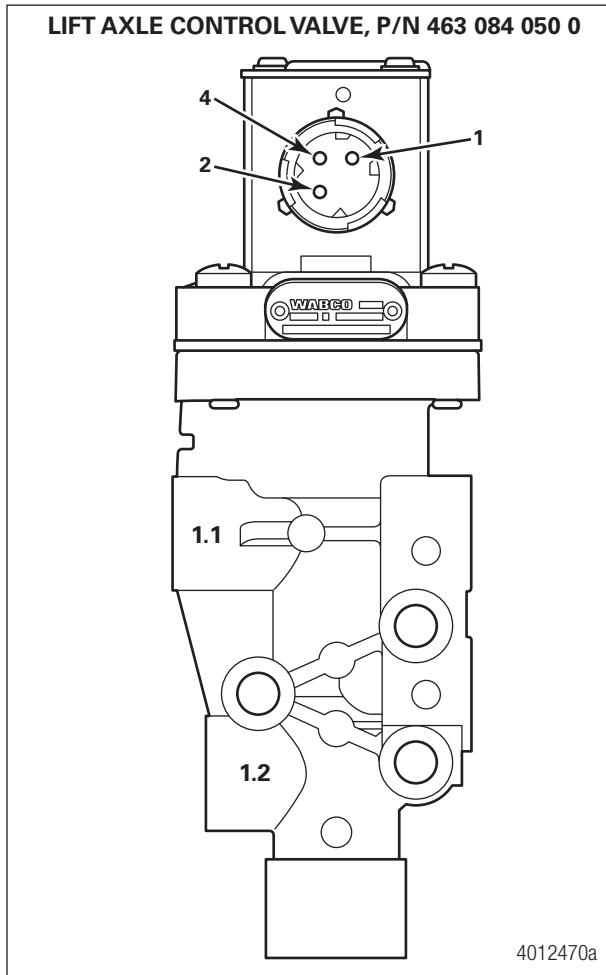
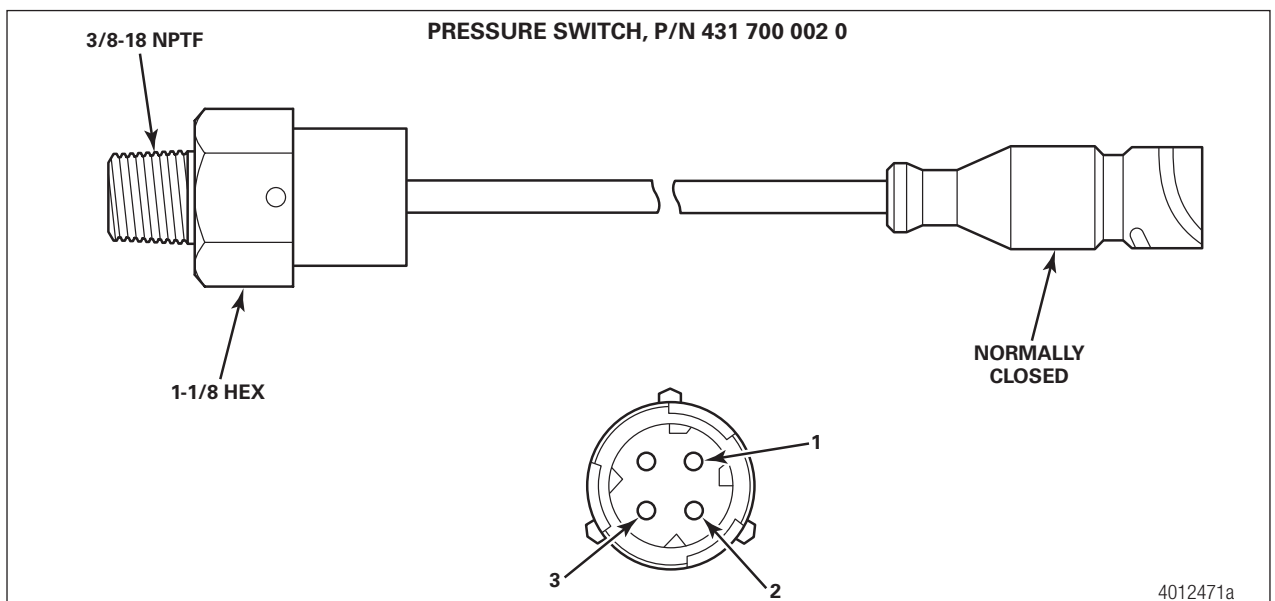

Fig. 9.5



Troubleshooting

Fig. 9.6

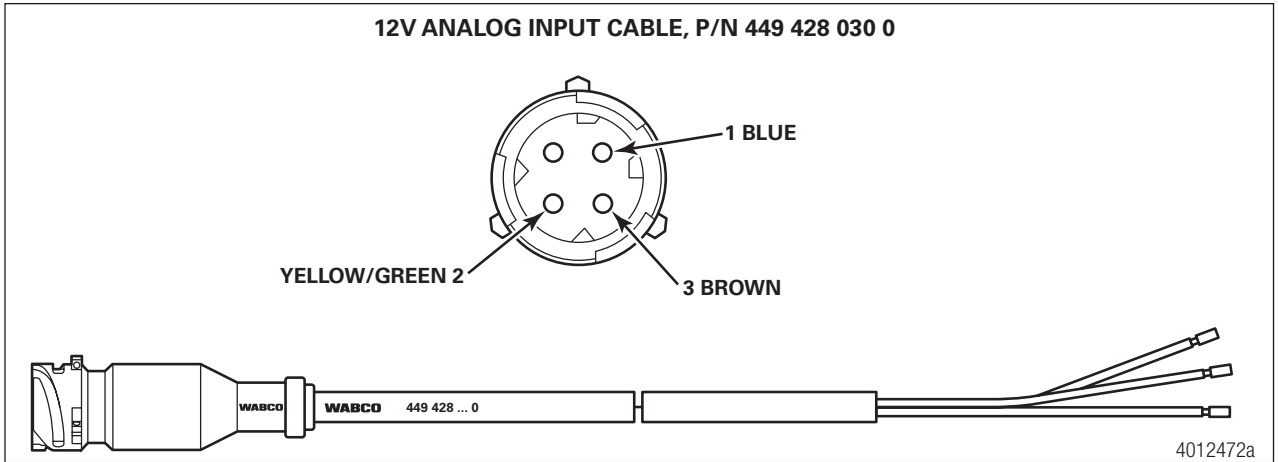

Fig. 9.7

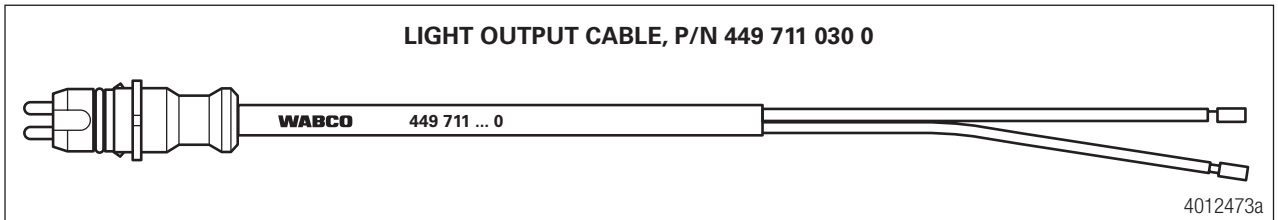
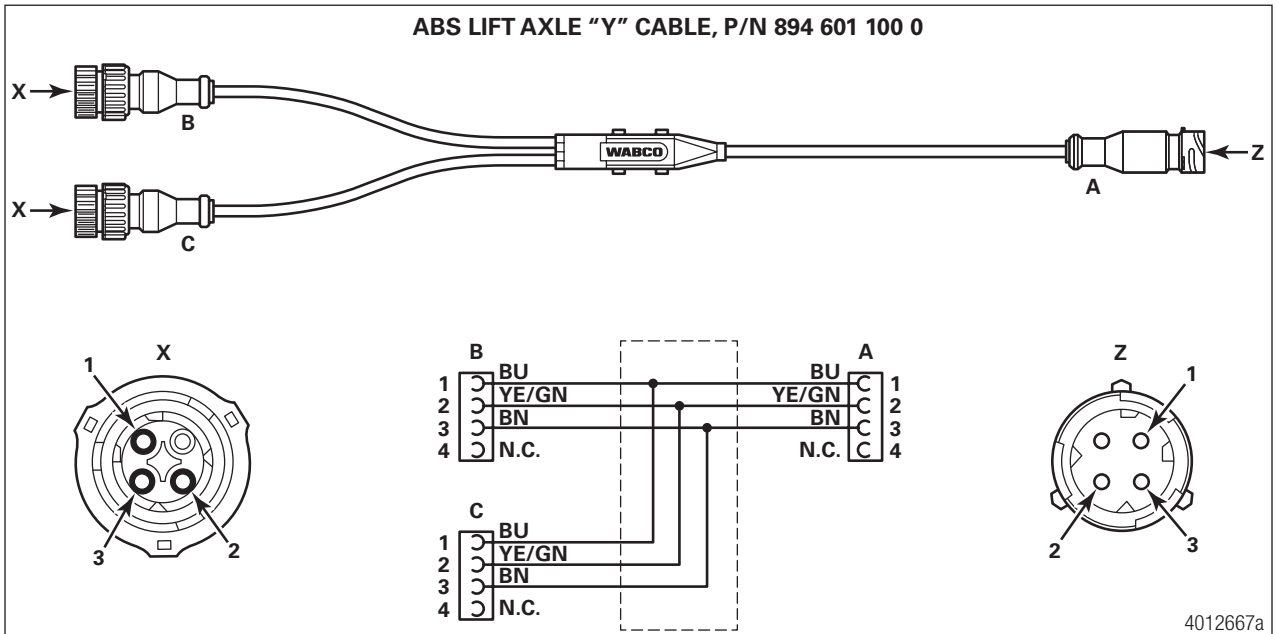
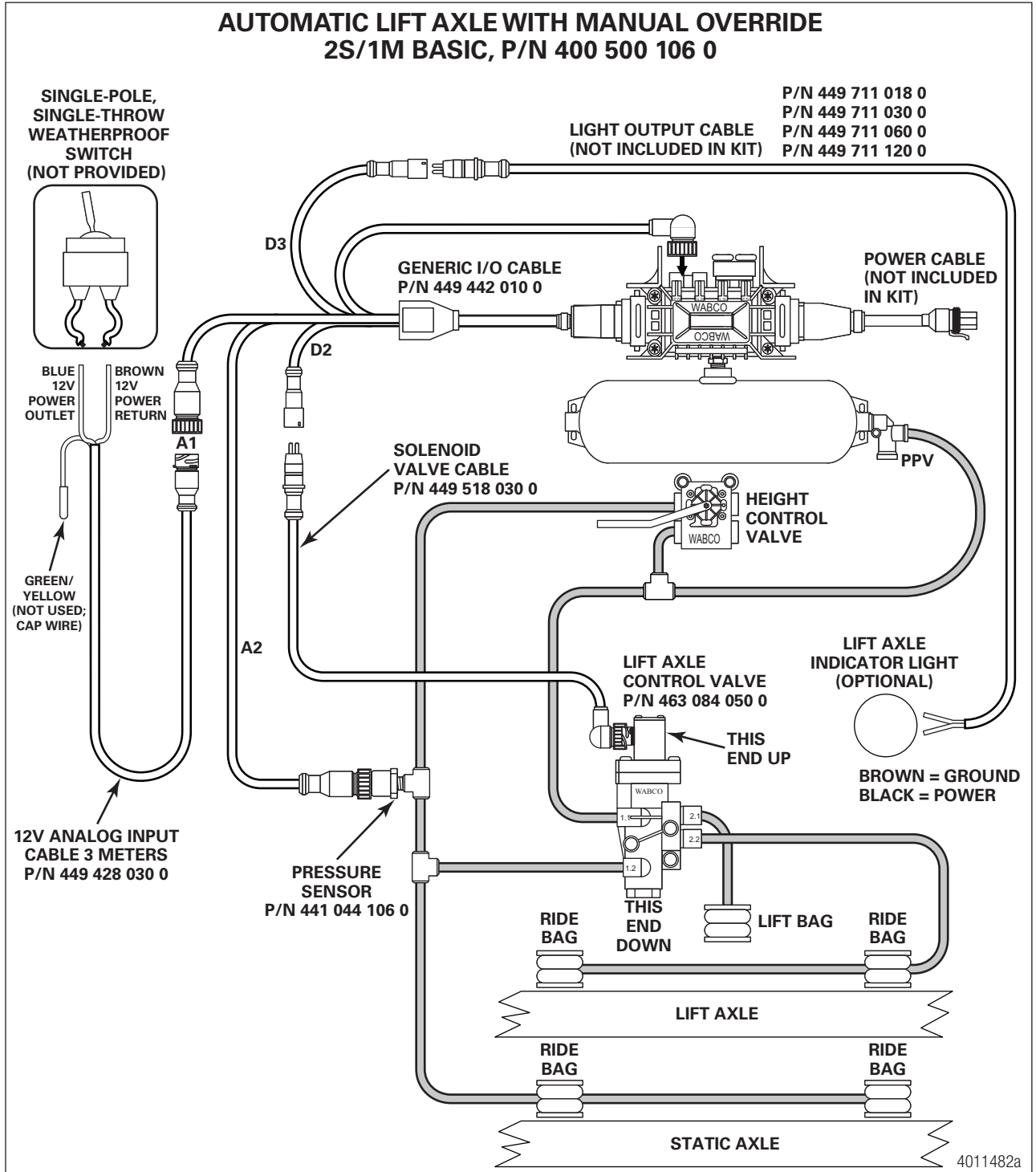

Fig. 9.8



Troubleshooting

Fig. 9.9



Troubleshooting

Fig. 9.10

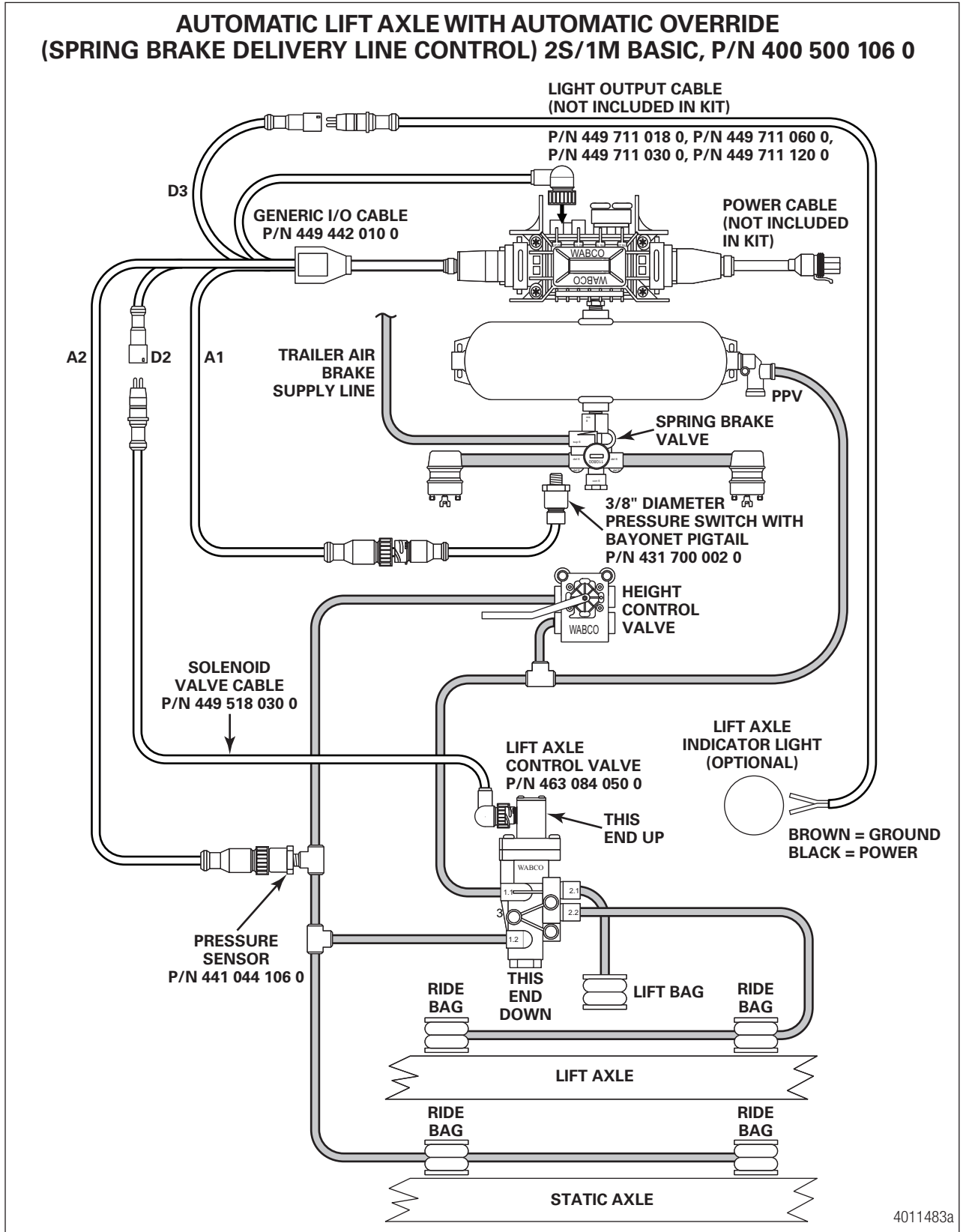

Troubleshooting

Fig. 9.11

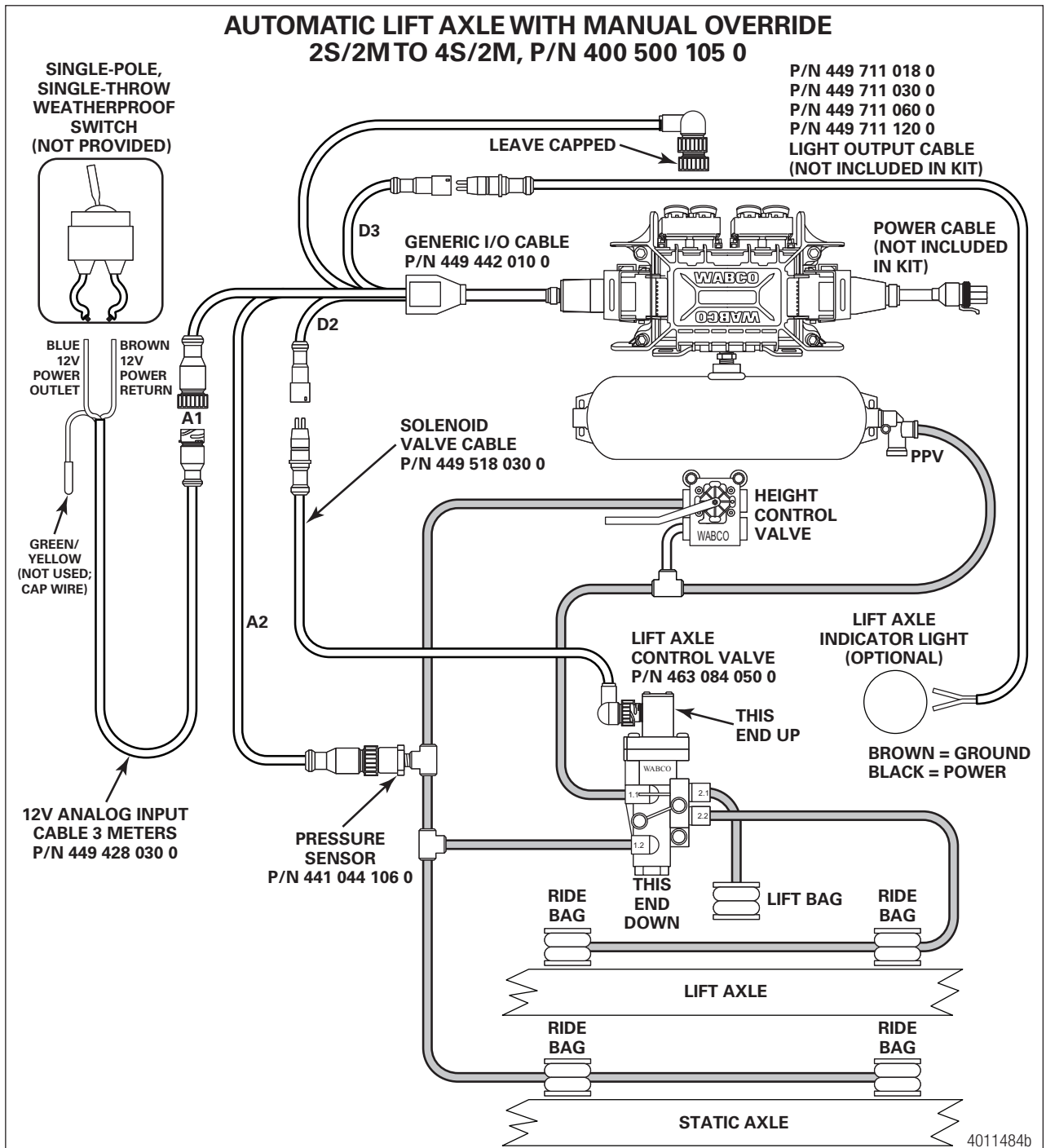

Troubleshooting

Fig. 9.12

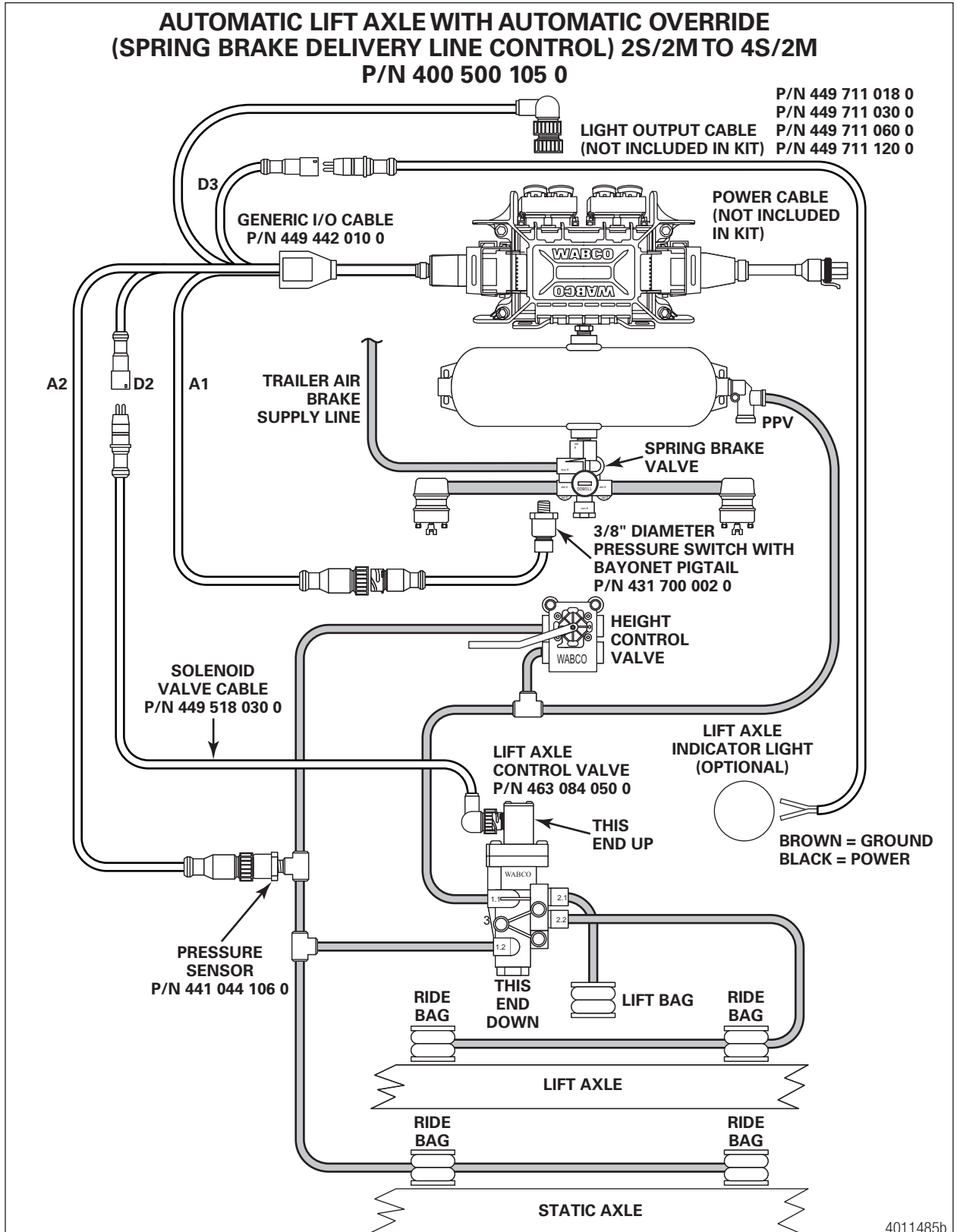

Troubleshooting

Fig. 9.13

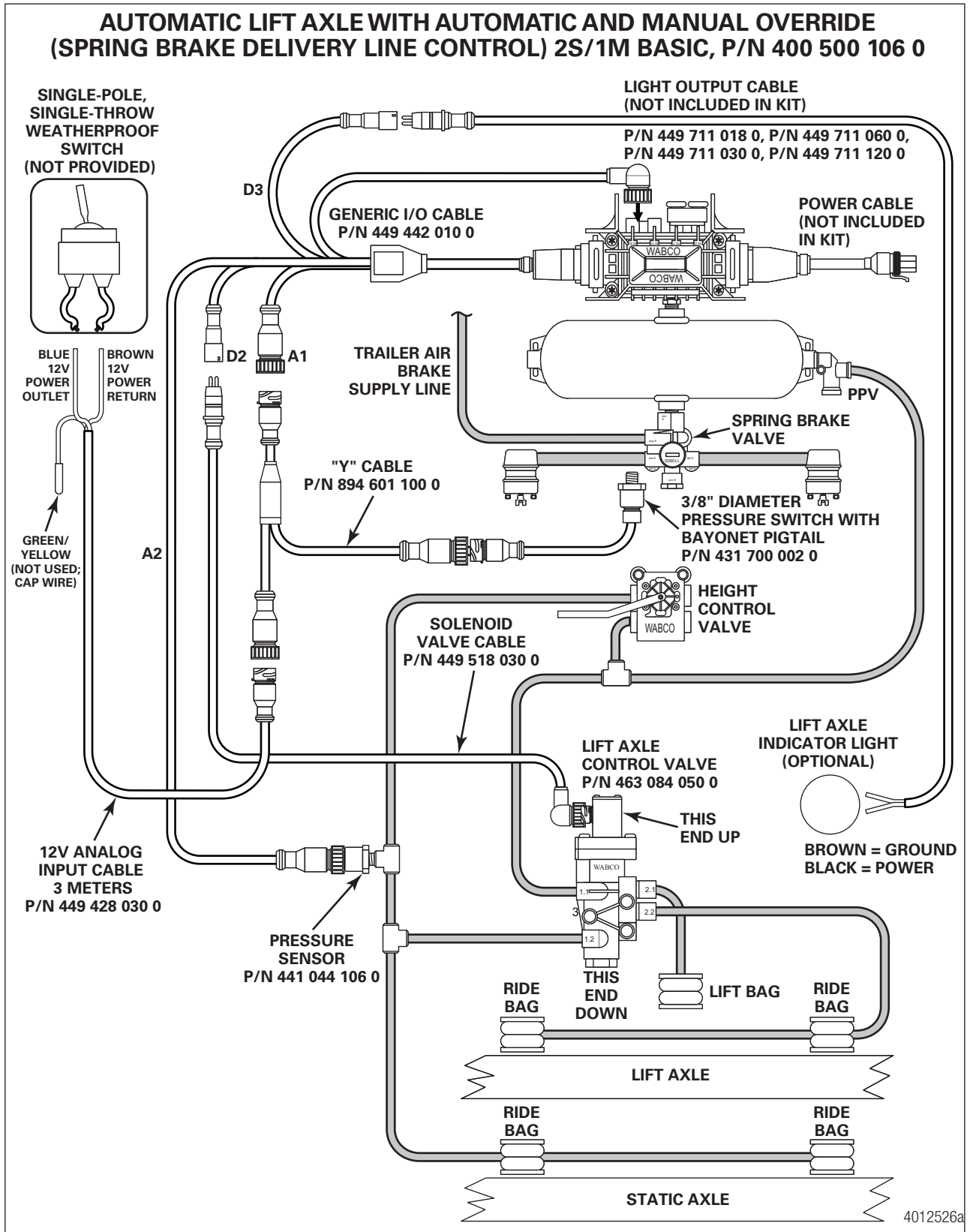

Troubleshooting

Fig. 9.14

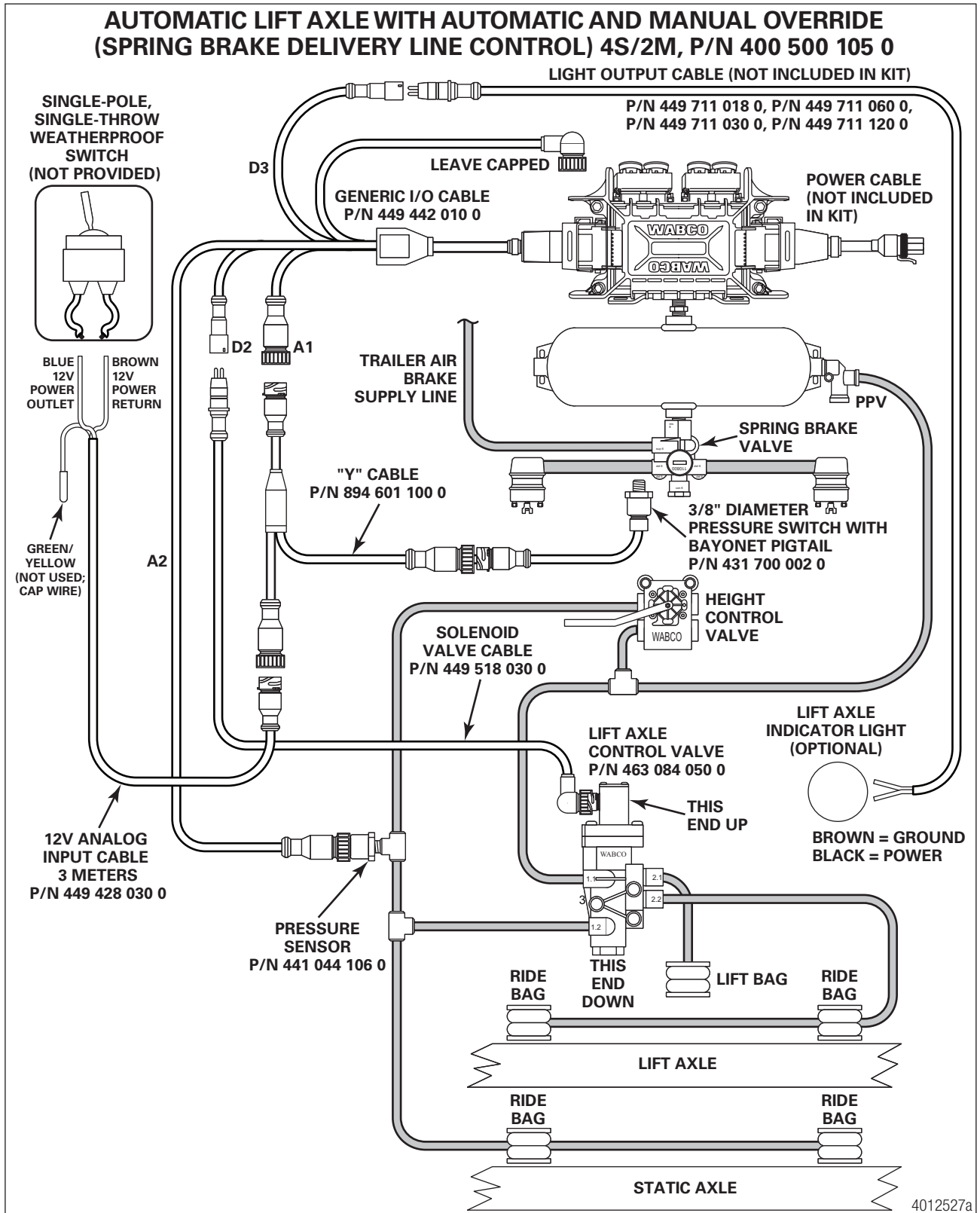

Troubleshooting

Fig. 9.15

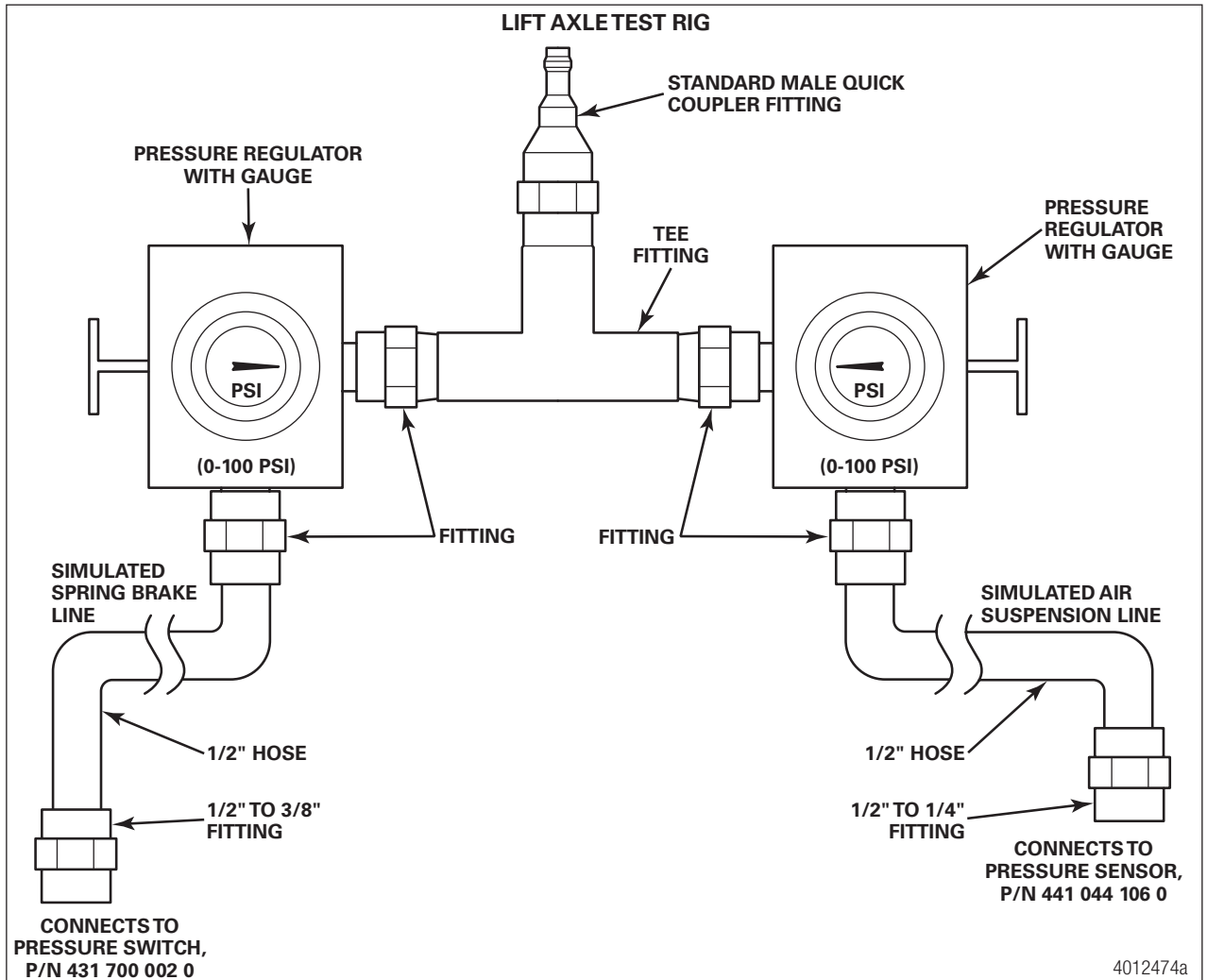
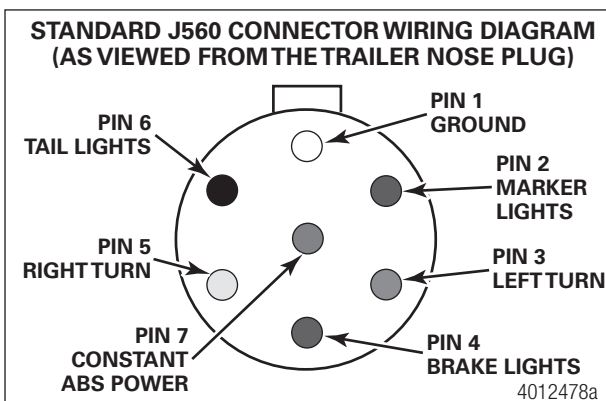

Fig. 9.16



Troubleshooting

9.2 Tag Axle Troubleshooting

ECUs 400 500 105 0 and 400 500 106 0 are the only trailer ABS valves that have Tag Axle functionality.

A tractor with a Tag Axle activation switch installed is required.

The first step taken when troubleshooting the Tag Axle system is to ensure that the system is pneumatically plumbed and electrically connected correctly. Refer to Figures 9.18, 9.19 and 9.24 in this section for the correct schematic, depending upon the configuration.

For additional information, refer to installation manual TP0886, Tag Axle Option Installation, available at zf.com/cvliterature.

When testing the Tag Axle system, ensure the trailer is supplied with 100-120 psi air pressure to the supply air and 12 volts DC power rated at a minimum of 10 amps to the trailer's constant power circuit.

Use of a volt-ohm meter may be required.

TIO files enable additional functionality, such as Tag Axle, for the InfoLink capable ECUs. If a TIO file needs to be removed or replaced, contact the WABCO Customer Care Center at 855-228-3203.

This troubleshooting section is based on the use of TOOLBOX PLUS™ Software version 12.2 or higher. If you have an earlier version of software, visit <https://wabco.snapon.com/> or contact your Snap-On dealer.

Troubleshooting

| Condition Experienced | Action to Take | Troubleshooting Details |
|-------------------------------------|---|---|
| Tag Axle Function Will Not Activate | Cycle trailer power. | ECU valve should audibly click during its power-up self-test. ABS warning light will illuminate and extinguish as a light test. If warning light remains on, begin diagnostics with TOOLBOX PLUS™ Software 12.2 or higher. If the ECU fails to click, ensure that the sensor extension cables are securely attached to the ECU and ensure that 12 volts is present at pin A-3 on the ECU power connector. Refer to Fig. 9.17. |
| | Retrieve diagnostic information via TOOLBOX PLUS™ Software. | If warning light is on, begin diagnostics with TOOLBOX PLUS™ Software 12.2 or higher. Repair and clear all faults found. |
| | Ensure no other TIO files have been loaded into the ECU. | In TOOLBOX PLUS™ Software 12.2 or higher under the Modify pull down, select the Notebook feature. Verify that only the tag axle TIO file has been activated or loaded. The tag axle TIO file is named "T_00102a.TIO". |
| | Ensure the tag axle system is plumbed correctly. | Refer to Figs. 9.18, 9.19 and 9.24. |
| | Inspect the cab-mounted tag axle toggle switch. | Using an ohm meter, verify the switch functionality. Switch should be a single-pole, single-throw toggle switch. Refer to the switch manufacturer's documentation for electrical contact information. 12v DC should be present when the switch is in the ON position and 0v DC when the switch is in the OFF position. |
| | Verify toggle switch installation. | The cab-mounted toggle switch is connected to 12v tractor power. The brown wire from the 12v analog input cable 449 428 030 0 is connected to the switch contact opposite the 12v tractor power. The green/yellow wire and the blue wire are unused and capped. Refer to Figs. 9.18 and 9.19. |
| | Verify switch output. | Turn the toggle switch to the "ON" position. 12v should be present at pin "A-4" on the ECU connector of generic I/O cable 449 442 010 0. Refer to Fig. 9.23. |

Troubleshooting

| Condition Experienced | Action to Take | Troubleshooting Details |
|-------------------------|--|---|
| | Verify 12v analog input cable is correctly connected to the generic I/O cable 449 442 010 0. | Ensure the 12v analog input cable 449 428 010 0 is securely fastened to the "A1" lead of the generic I/O cable 449 442 010 0. |
| | Verify the 12v analog input cable 449 428 030 0 integrity. | Using a volt/ohm meter, check for shorted or open circuits on the 12v analog input cable. Refer to Fig. 9.20. |
| | Inspect the lift axle control valve 463 084 050 0. | Using an ohm meter, the resistance across the two pins on the 3/2 solenoid valve show read (at room temperature) 9 ohms (+/- 2 ohms). Refer to Fig. 9.21. |
| | Verify the operation of the 3/2 solenoid valve 472 170 997 0. | Apply 12v DC power and ground to pins 1 and 2 in the 3/2 valve's bayonet connector. The solenoid should energize and dump the air on the tag axle. Removing the power and ground will cause the tag axle air bags to re-inflate. |
| | Check 3/2 solenoid valve cable 449 518 010 0 integrity. | Using a volt/ohm meter, check for shorted or open circuits on the solenoid valve cable. Refer to Fig. 9.22. |
| | Verify generic I/O cable 449 442 010 0 is correctly hooked up. | Refer to Figs. 9.18 and 9.19. Ensure that lead "A2" is unused and correctly capped. |
| | Check generic I/O cable 449 442 010 0 integrity. | Using a volt/ohm meter, check for shorted or open circuits on the multiple I/O cable 449 442 010 0. Refer to Fig. 9.23. |
| Tag Axle Will Not Reset | Using TOOLBOX PLUS™ Software, ensure there are no active faults. | Repair and clear all active faults. Cycle the ECU power. |
| | Ensure the tag axle system is plumbed correctly. | Refer to Figs. 9.18, 9.19 and 9.24. |
| | Verify ECU is reading wheel speed. | Using TOOLBOX PLUS™ Software 12.2 or higher, perform the Sensor Test from the Component Tests pull down. |
| | Inspect the cab-mounted tag axle toggle switch. | Using an ohm meter, verify the switch functionality. Switch should be a single-pole, single-throw toggle switch. Refer to the switch manufacturer's documentation for electrical contact information. |
| | Verify toggle switch installation. | The cab-mounted toggle switch is connected to 12v tractor power. The brown wire from the 12v analog input cable 449 428 030 0 is connected to the switch contact opposite the 12v tractor power. The green/yellow wire and the blue wire are unused and capped. Refer to Figs. 9.18 and 9.19. |
| | Verify switch output. | Turn the toggle switch to the "ON" position. 12v should be present at pin "A-4" on the ECU connector of generic I/O cable 449 442 010 0. |
| | Verify 12v analog input cable is correctly connected to the generic I/O cable 449 442 010 0. | Ensure the 12v analog input cable 449 428 010 0 is securely fastened to the "A1" lead of the generic I/O cable 449 442 010 0. |
| | Verify the 12v analog input cable 449 428 030 0 integrity. | Using a volt/ohm meter, check for shorted or open circuits on the 12v analog input cable. See Fig. 9.23. |

Troubleshooting

| Condition Experienced | Action to Take | Troubleshooting Details |
|---|--|--|
| | Verify the operation of the 3/2 solenoid valve 472 170 997 0. | Apply 12v DC power and ground to pins 1 and 2 in the 3/2 valve's bayonet connector. The solenoid should energize and dump the air on the tag axle. Removing the power and ground will cause the tag axle air bags to re-inflate. |
| Tag Axle Comes to Rest on Axle Bump Stops | Using TOOLBOX PLUS™ Software, ensure there are no active faults. | Repair and clear all active faults. Cycle the ECU power. |
| | Ensure tag axle system is plumbed correctly. | Refer to Figs. 9.18, 9.19 and 9.24. |
| | Verify the 3/2 solenoid valve has optional components installed. | Refer to Fig. 9.24. |
| | Check for air leaks. | Ensure no air leaks at the 1/4" to 3/8" adapter, the residual pressure valve and the check valve. Refer to Fig. 9.24. |
| Tag Axle is Intermittent | Using TOOLBOX PLUS™ Software, ensure there are no active faults. | Repair and clear all active faults. Cycle the ECU power. |
| | Verify tag axle system is plumbed correctly and check for air leaks. | Refer to Figs. 9.18, 9.19 and 9.24. |
| | Ensure that the air volume capacity of the trailer meets trailer OEM standards for operating a tag axle. | Verify the output of the towing vehicle's air compressor to the trailer. |
| Optional Tag Axle Indicator Light Does Not Function | Using TOOLBOX PLUS™ Software, ensure there are no active faults. | Repair and clear all active faults. Cycle the ECU power. |
| | Verify the type of tag axle 12 volt DC indicator lamp. | The lamp must be an incandescent lamp or a load-resistored LED lamp. |
| | Verify the lamp is correctly wired to the light output cable 449 711 120 0. | The black wire is hooked to power and the brown wire is hooked to ground. |
| | Verify the integrity of light output cable 449 711 150 0. | Using a volt/ohm meter, check for shorted or open circuits on the light output cable. Refer to Fig. 9.25. |
| | Verify the generic I/O cable 449 442 010 0 integrity. | Using a volt/ohm meter, check for shorted or open circuits on the "D3" lead of the generic I/O cable. Refer to Fig. 9.23. |
| Optional Tag Axle LED Indicator Lamp Stays on Faintly | Inspect the type of indicator lamp. | Replace generic LED lamp with a load-resistored LED or incandescent lamp. The black wire is hooked to power and the brown wire is hooked to ground. |

Troubleshooting

Fig. 9.17

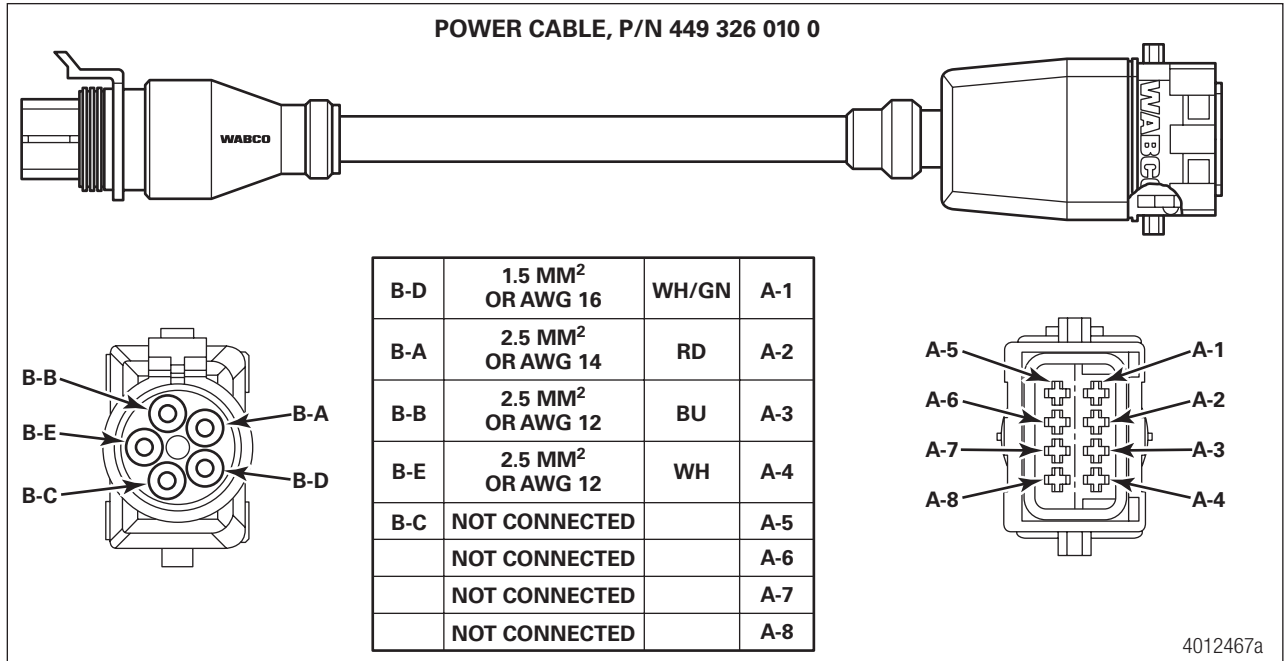

Troubleshooting

Fig. 9.18

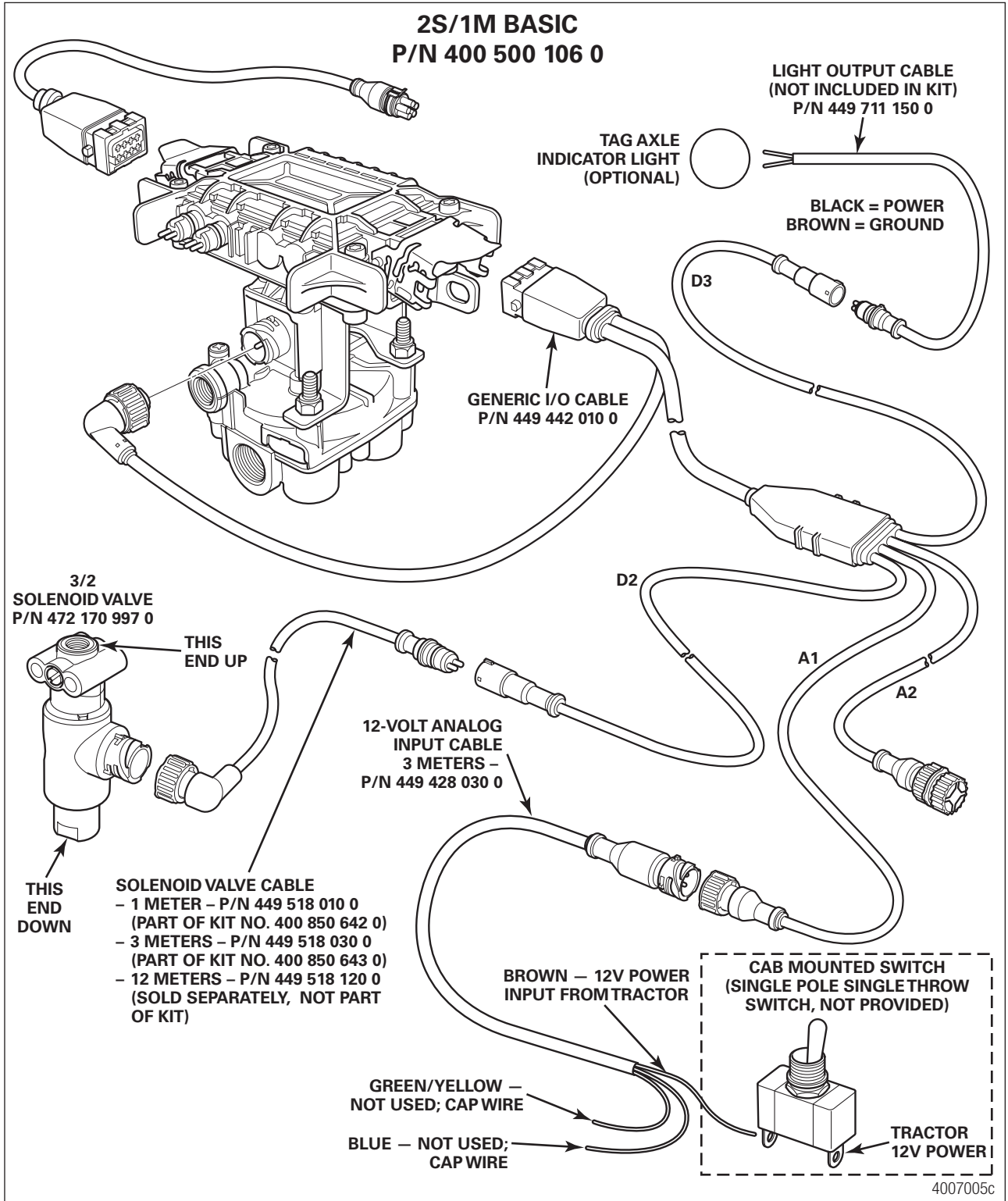

Troubleshooting

Fig. 9.19

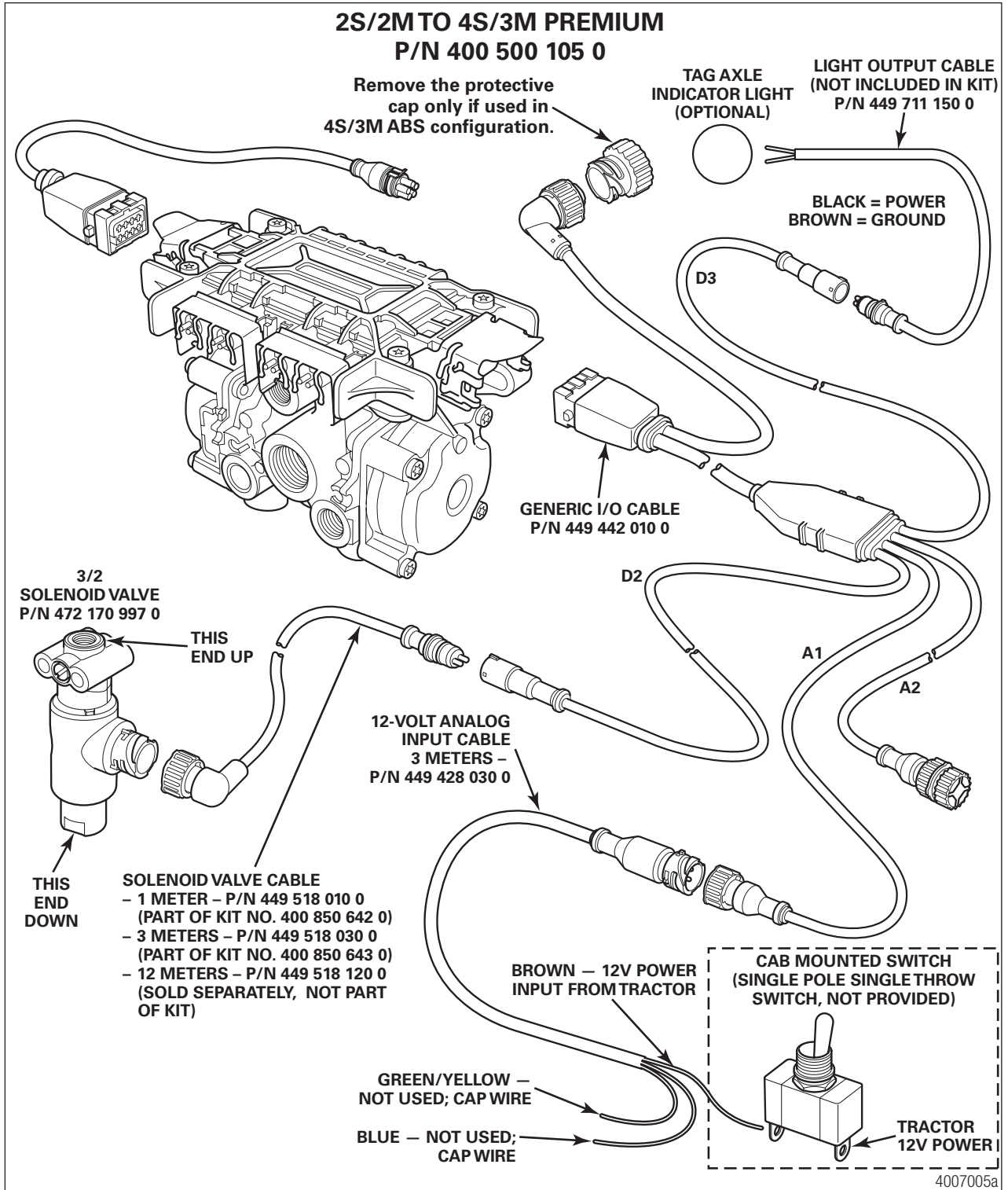

Troubleshooting

Fig. 9.20

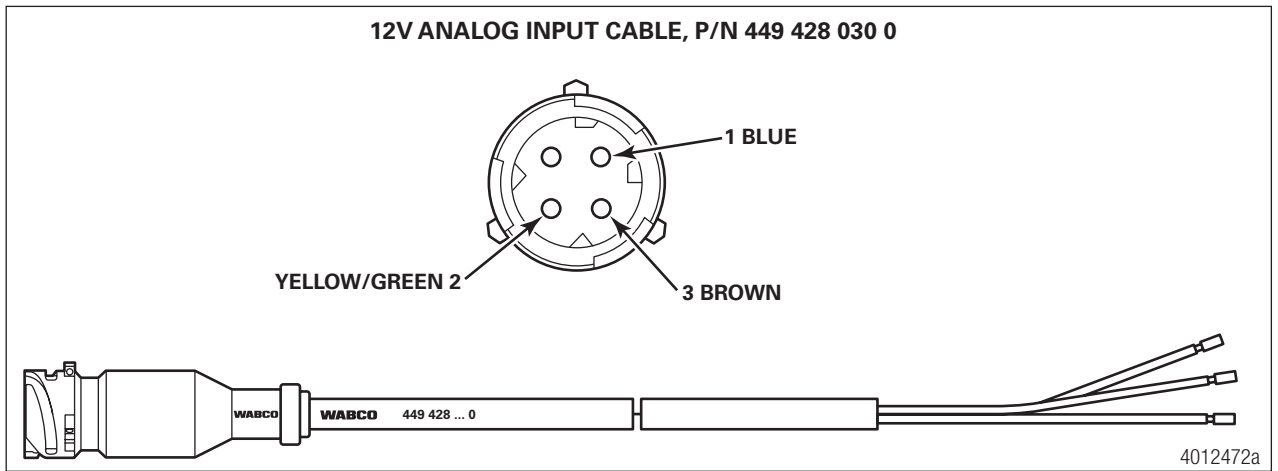
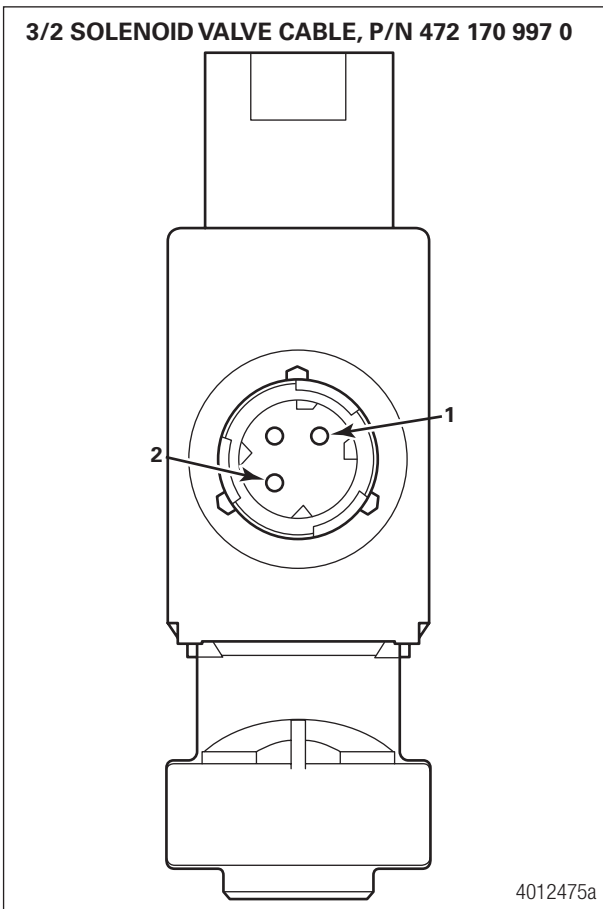

Fig. 9.21



Troubleshooting

Fig. 9.22

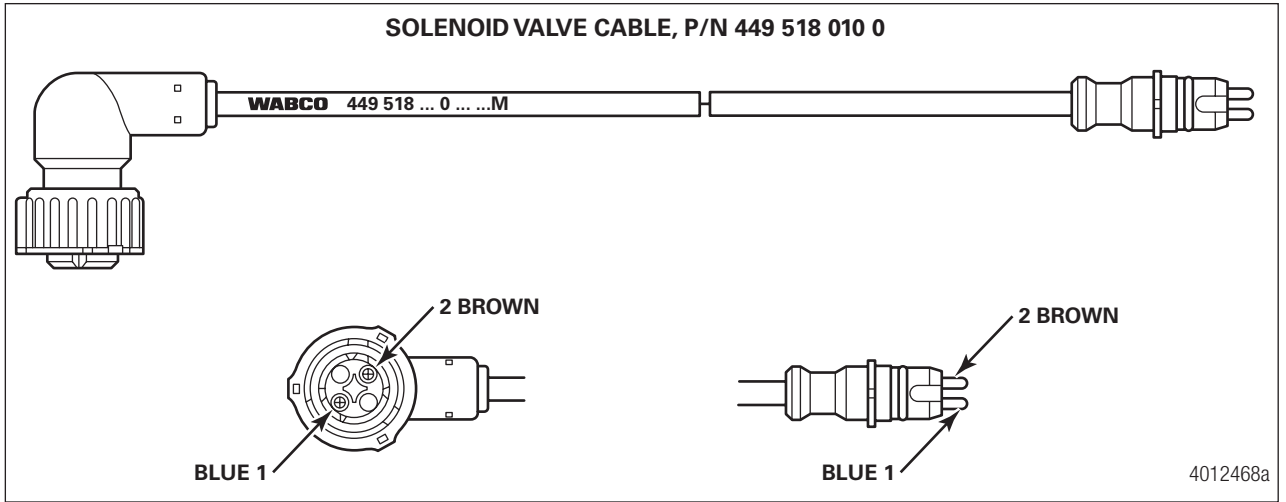
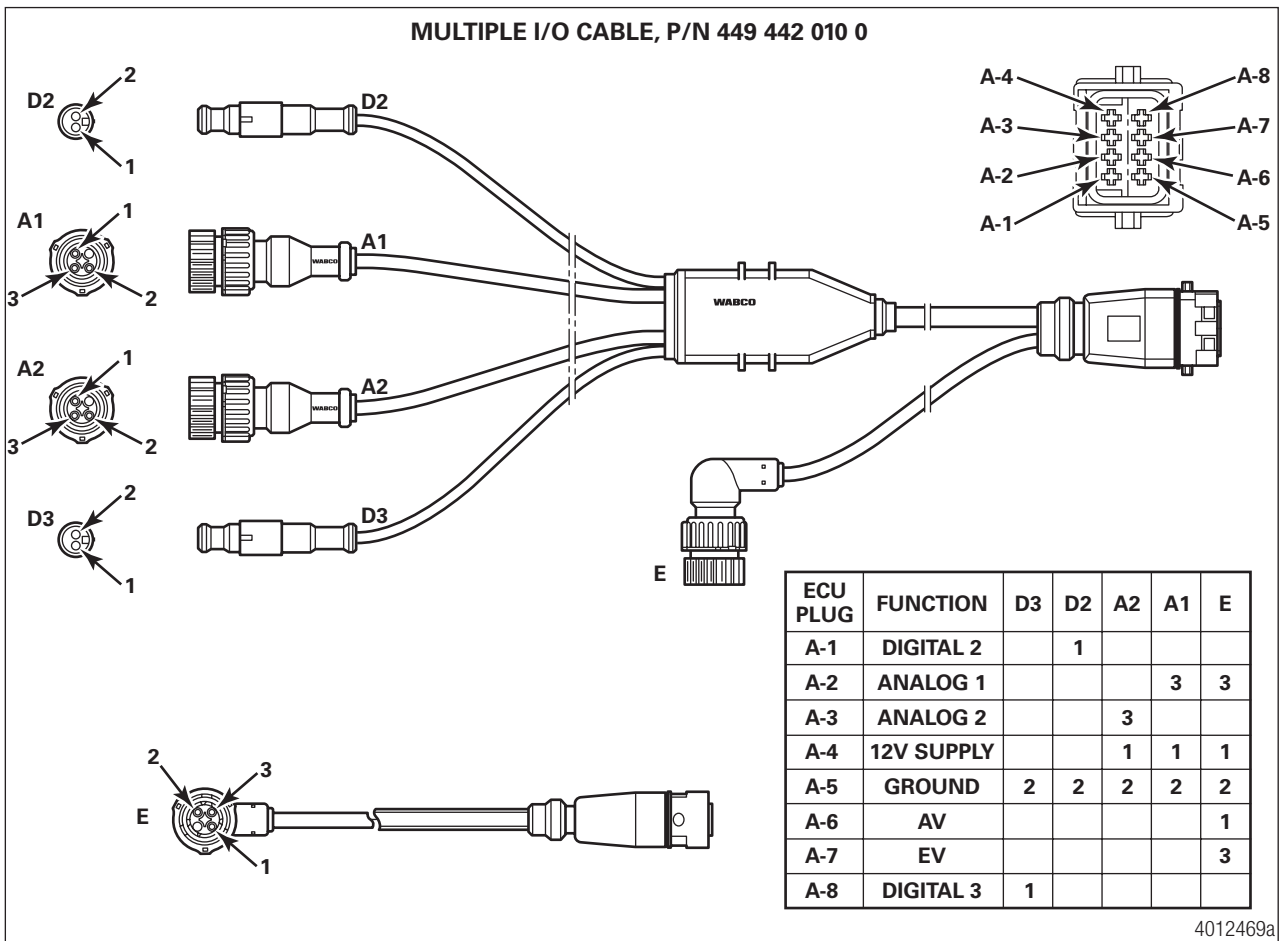

Fig. 9.23



Troubleshooting

Fig. 9.24

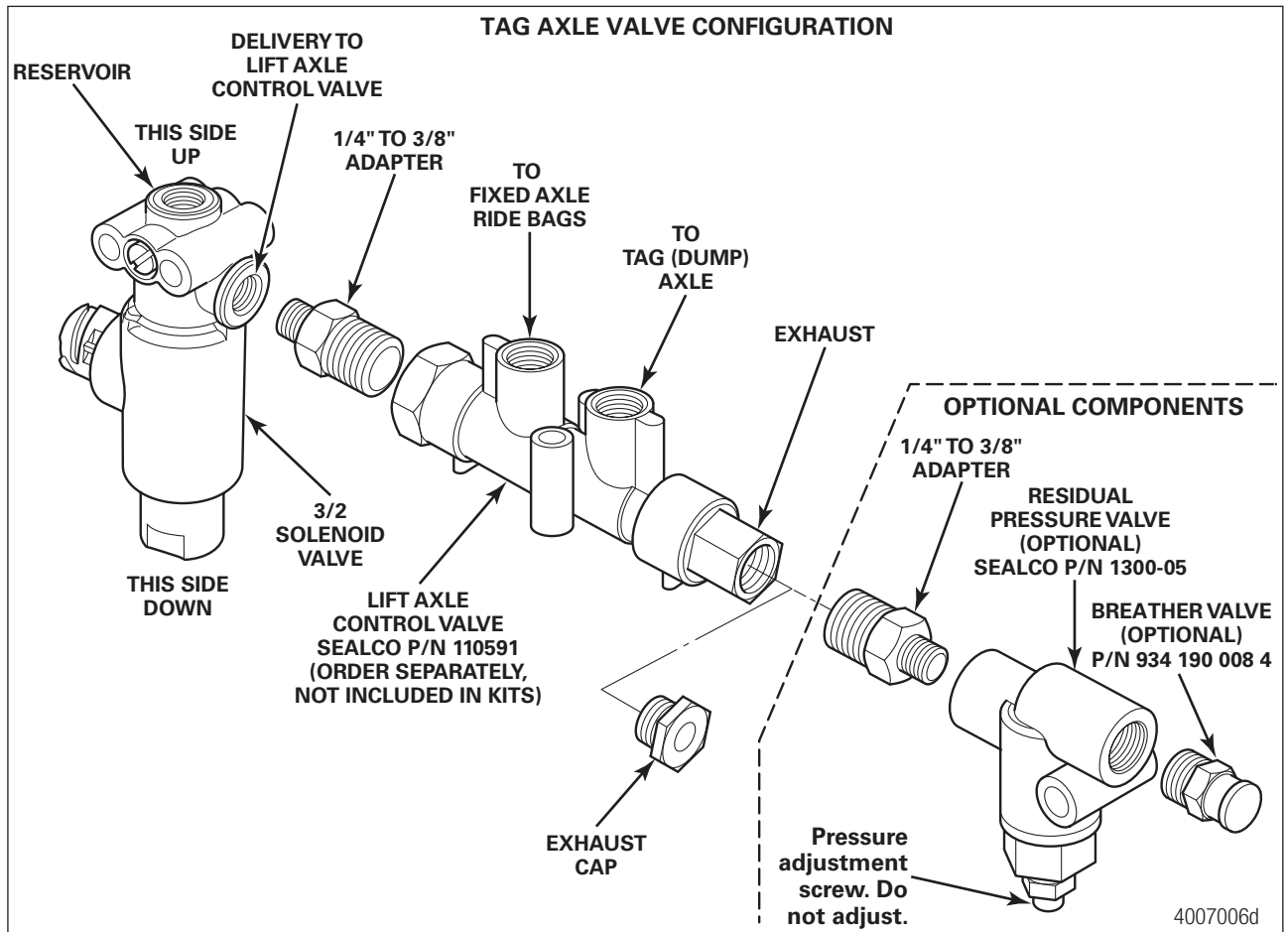
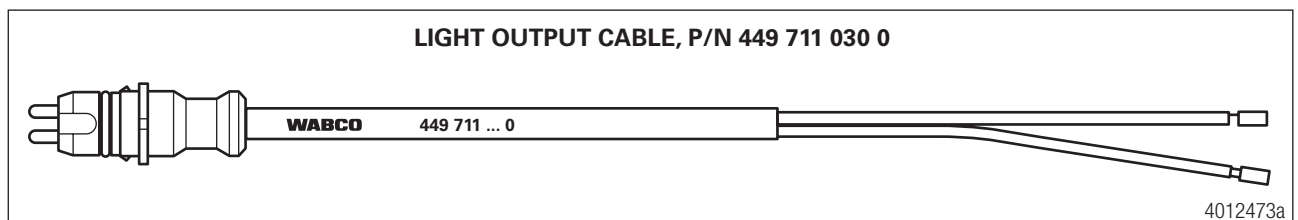

Fig. 9.25



Troubleshooting

9.3 Rear Aero Auto Deployment System (RAADS) Troubleshooting

ECUs 400 500 105 0 and 400 500 106 0 are the only trailer ABS valves that support RAADS functionality.

The first step taken when troubleshooting the RAADS is to ensure that the system has its electrical components connected correctly. Refer to Figure 9.26 for the system diagram and the system wiring 2S/1M and 4S/2M RAADS ECU cables.

For additional information, refer to technical publication TP16107, RAADS Installation Manual, available at zf.com/cvliterature. Also reference the TrailerTail™ Maintenance Manual ATD003047 at stemco.com.

When testing the system, ensure that 12-volts of DC power rated at a minimum of 10 amps is supplied to the trailer's constant power circuit.

Use of a volt-ohm meter may be required.

This troubleshooting section is based on the use of TOOLBOX PLUS™ Software version 12.2 or higher. If you have an earlier version of the software, visit <https://wabco.snapon.com/> or contact your Snap-On dealer.

| Condition Experienced | Action to Take | Troubleshooting Details |
|--|---|---|
| RAADS doors do not open once vehicle speed exceeds 35 mph. | Ensure trailer has constant power. | At ignition key-on, check to ensure that the ABS warning lamp performs a light check (illuminating for 2-5 seconds just after keyon). |
| | Inspect Rear Aero Auto Deployment cable for continuity. | Ensure actuator connectors B and C are correctly installed. Check for open or shorted circuits. Refer to Figs. 9.27, 9.28 and the Rear Aero Auto Deployment Cable Pin Out Table. |
| | Ensure correct ECU parameter file is loaded. | Re-program ECU with TOOLBOX PLUS™ Software 12.2 or higher. The system software configuration is included within these TOOLBOX PLUS™ Software releases. To check that the system has accepted the program or has previously been programmed with the software, access the Notebook section of the TOOLBOX PLUS™ Software for "GIO file = Rear Aero Auto Deployment.tio". |
| | Ensure correct wheel speed sensor installation. | Diagnose warning lamp using TOOLBOX PLUS™ Software 12.2 or higher. Diagnostic checks on the wheel speed sensors and wiring may be required based on the information provided by TOOLBOX PLUS™ Software. See the "Diagnostics" section of this manual for additional information. |
| | Ensure electrical latch actuators function correctly. | See STEMCO's maintenance manual. |
| | Inspect aerodynamic door for correct movement. | See STEMCO's maintenance manual. |
| RAADS doors open at a vehicle speed other than 35 mph. | Ensure wheel diameter and number of tone wheel teeth calibrations are accurate. | Re-program the ECU for the Rear Aero Auto Deployment system using TOOLBOX PLUS™ Software 12.2 or higher. See technical publication TP16107 for additional instructions. |

Troubleshooting

| Condition Experienced | Action to Take | Troubleshooting Details |
|----------------------------------|---|---|
| RAADS doors do not latch closed. | Ensure electrical latch actuators function correctly. | See STEMCO's maintenance manual. |
| | Inspect cable for short circuit. | Ensure that actuator pins B/C-2 and B/C-3 do not show full system voltage (battery voltage) while the system is parked. |

Fig. 9.26

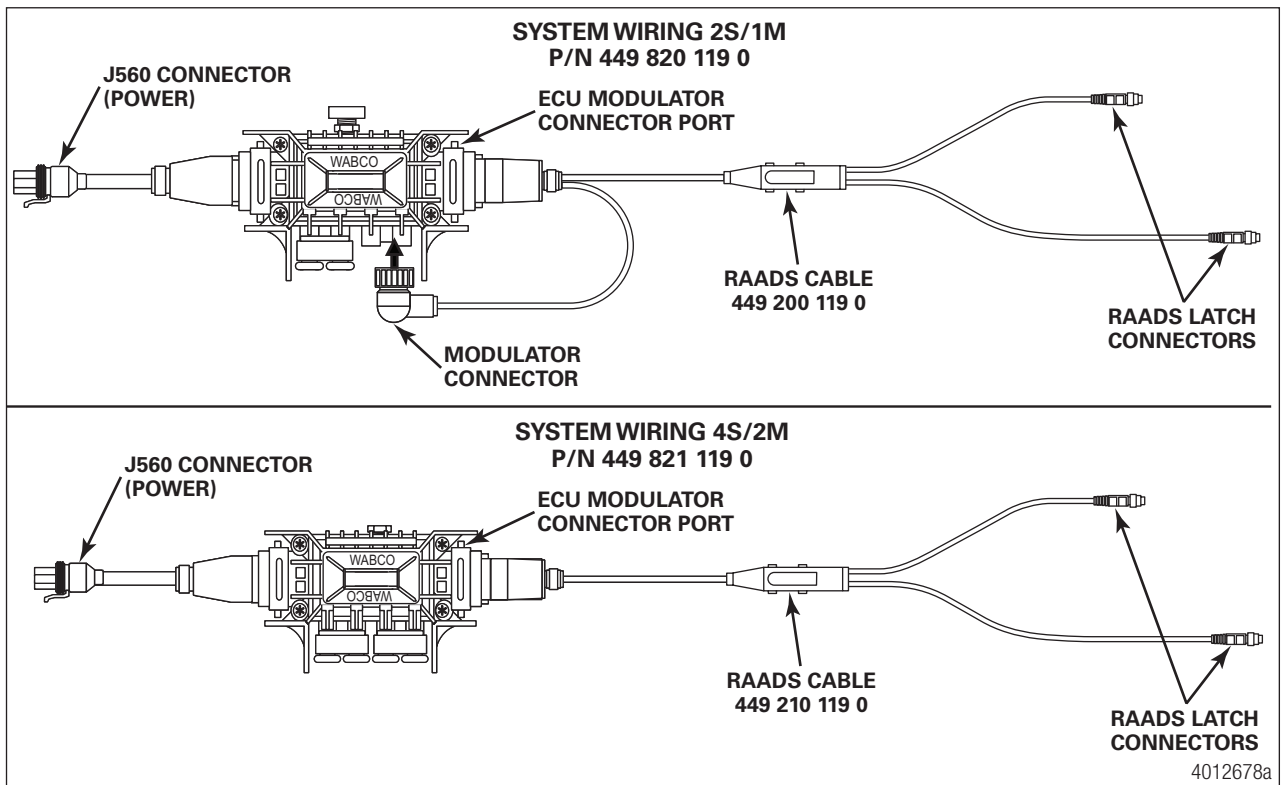

Troubleshooting

Fig. 9.27

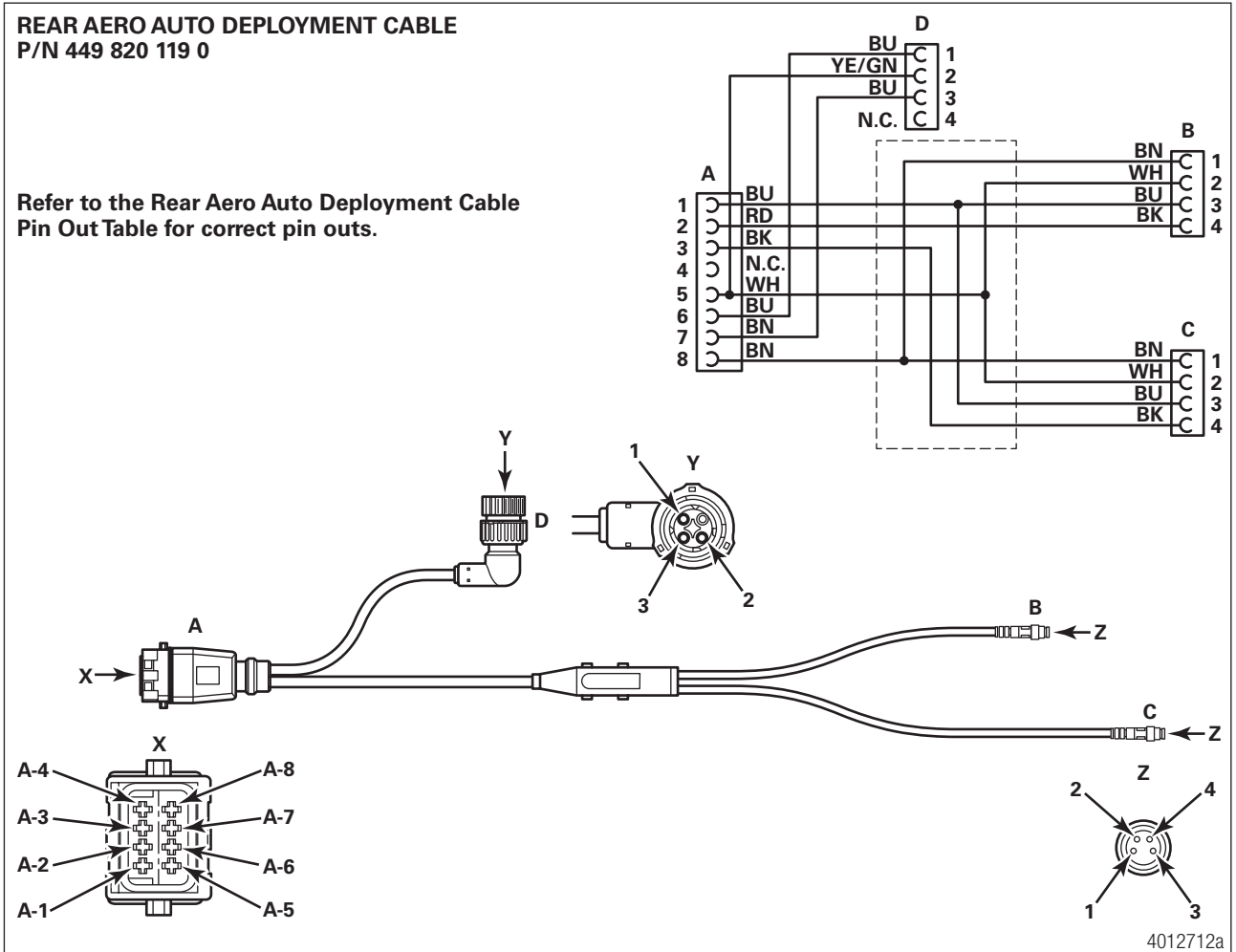

Troubleshooting

Fig. 9.28

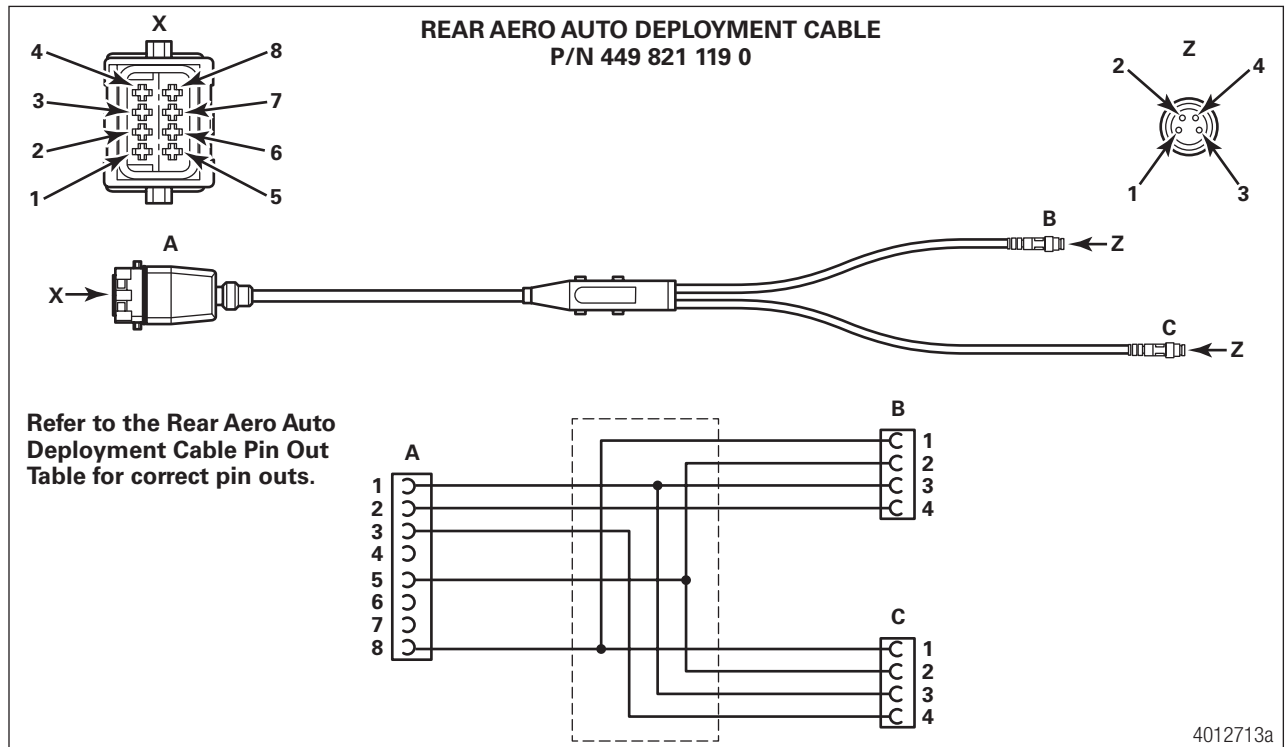

4012713a

REAR AERO AUTO DEPLOYMENT CABLE PIN OUT TABLE

| ECU-A | ACTUATOR-B | ACTUATOR-C | ACTUATOR-D | FUNCTION |
|-------|------------|------------|------------|-------------------|
| A-1 | B-3 | C-3 | | CONTROL FLAG |
| A-2 | B-4 | | | LATCH 1 FEEDBACK |
| A-3 | | C-4 | | LATCH 2 FEEDBACK |
| A-4 | | | | — |
| A-5 | B-2 | C-2 | D-2 | GROUND |
| A-6 | | | D-1 | MODULATOR EXHAUST |
| A-7 | | | D-3 | MODULATOR HOLD |
| A-8 | B-1 | C-1 | | LATCH POWER |

Troubleshooting

9.4 Tire Inflation Communication System Troubleshooting

Refer to TP0735, Tire Inflation Communication System Manual found at zf.com/cvliterature.

ECUs 400 500 105 0 and 400 500 106 0 are the only trailer ABS valves that have Tire Inflation Communication System functionality.

The first step taken when troubleshooting the Tire Inflation Communication System is to ensure that the system is electrically connected correctly. Refer to Figure 9.30.

For additional information, refer to TP0735, Tire Inflation Communication System, available at zf.com/cvliterature.



If the Tire Inflation system status lamp is not present or is not functioning, then the Tire Inflation Communication System will not function.

TIO files enable additional functionality such as tire monitoring, for the InfoLink capable ECUs. If a TIO needs to be replaced or removed, contact the WABCO Customer Care Center at 855-228-3203.

This troubleshooting section is based on the use of TOOLBOX PLUS™ Software version 12.2 or higher. If you have an earlier version of TOOLBOX PLUS™ Software, visit <https://wabco.snapon.com/> or contact your Snap-On dealer.

| Condition Experienced | Action to Take | Troubleshooting Details |
|--|--|---|
| MTIS LED Illuminates with a Dim Glow All the Time | Confirm the MTIS LED is an incandescent or WABCO LED with resistor part number 31263-20. | Replace light as necessary. Ensure light is correctly grounded. |
| WABCO Tire Inflation Communication System is not Broadcasting a “Low Tire Pressure” Message When There is a Fill Event and the MTIS Light is Illuminated | Correct installation needs to be verified. | Confirm WABCO MTIS Communication System is installed per Figs. 9.31 and 9.32. Make sure all electrical connections are fully seated. |
| | ECU valve should audibly click during its power-up self-test. | Ensure that 12 volts is present across pin A-3 and (Ground Pin) on the ECU power connector. |
| | Check continuity of the power/I/O cable. | Check continuity for the 449 324 XXX X D1 cable from the 8-pin connector (Pin 5) to the 2-pin sensor socket (C1). Refer to Fig. 9.29. Check diode on pre-installed MTIS cable pigtail. Place the volt/ ohm meter to “Diode”. Place red lead on single male pin. Place the black lead on the dual tab connector. Continuity should be observed on the volt/ ohm meter. Switching the leads in the opposite direction, an “Open” should be displayed on the volt/ ohm meter. Refer to Fig. 9.30. |
| | Confirm part number 400 500 105 0 or 400 500 106 0 is installed. | Connect TOOLBOX PLUS™ Software 12.2 or higher and part number can be viewed on the Trailer ABS main screen. |
| | Confirm T_0109b.tio has been installed to the ECU. | To access the Notebook section of the ECU, perform the following: 1. Select Modify on the top toolbar of the Trailer ABS TOOLBOX application. 2. Select Notebook to confirm T_0109b.tio can be viewed in the “Service Information” area. 3. If T_0109b.tio is not visible in the Notebook, go back to Loading TIO Files section of this manual. |

Troubleshooting

| Condition Experienced | Action to Take | Troubleshooting Details |
|---|--|---|
| “Low Tire Pressure” Message is Being Broadcasted All the Time | Correct installation needs to be verified. | Confirm WABCO MTIS communication system is installed per illustration Figs. 9.31 and 9.32. Make sure all electrical connections are fully seated. |
| | Confirm the MTIS LED is an incandescent or WABCO LED w/ resistor part number 31263-20. | Replace light as necessary. Ensure light is grounded. |
| PLC Display Does Not Flash a “Low Tire Pressure” Message When MTIS Has a Fill Event | Connect to InfoLink-equipped ECU using TOOLBOX PLUS™ Software 12.2 or higher. | Download T_0109b.tio parameter file to the InfoLink equipped ECU. Remove 12-volt power from the ECU. Apply 12-volt power to the ECU. Create fill event on the MTIS by opening the petcock to the MTIS control box. See Fig. 9.31. |
| MTIS LED Does Not Illuminate During a Fill Event | Correct installation needs to be verified. | Confirm MTIS system is installed per MM14P. Confirm MTIS LED is not burned out. Replace MTIS LED as required with WABCO part number 31263-20. |
| The Parameter File T_0109b.tio Has Been Successfully Downloaded to the ECU, but MTIS Message is Not Being Broadcasted | Confirm T_0109b.tio is visible in the “Notebook” section of TOOLBOX PLUS™ Software 12.2 or higher. | Call the WABCO Customer Care Center at 855-228-3203. |

Fig. 9.29

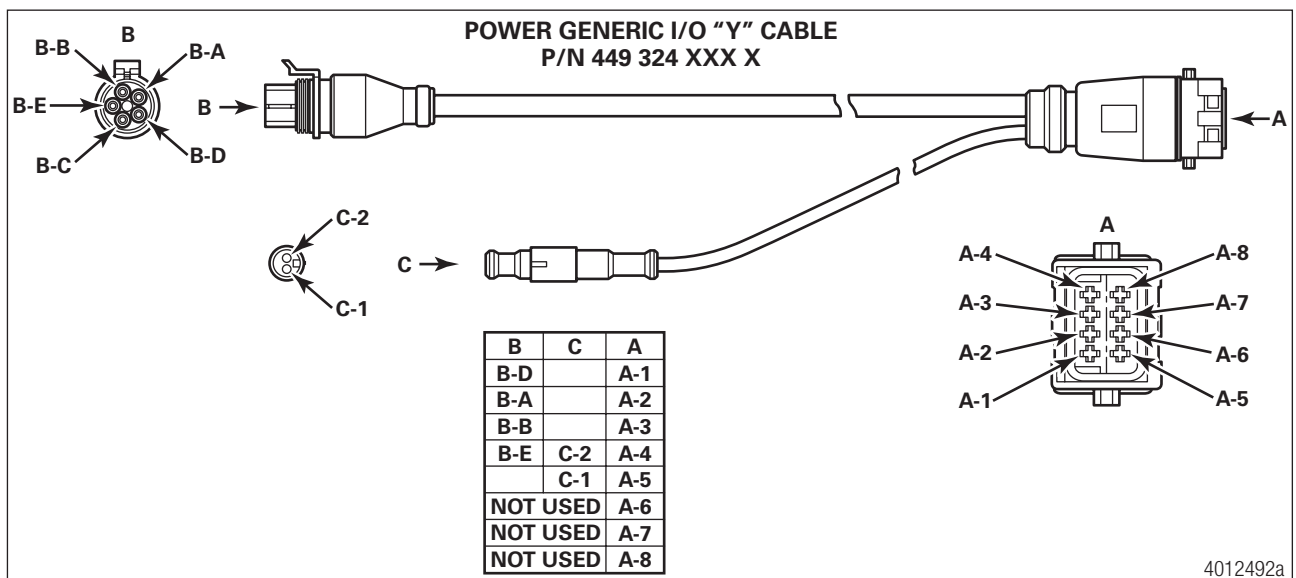

Troubleshooting

Fig. 9.30

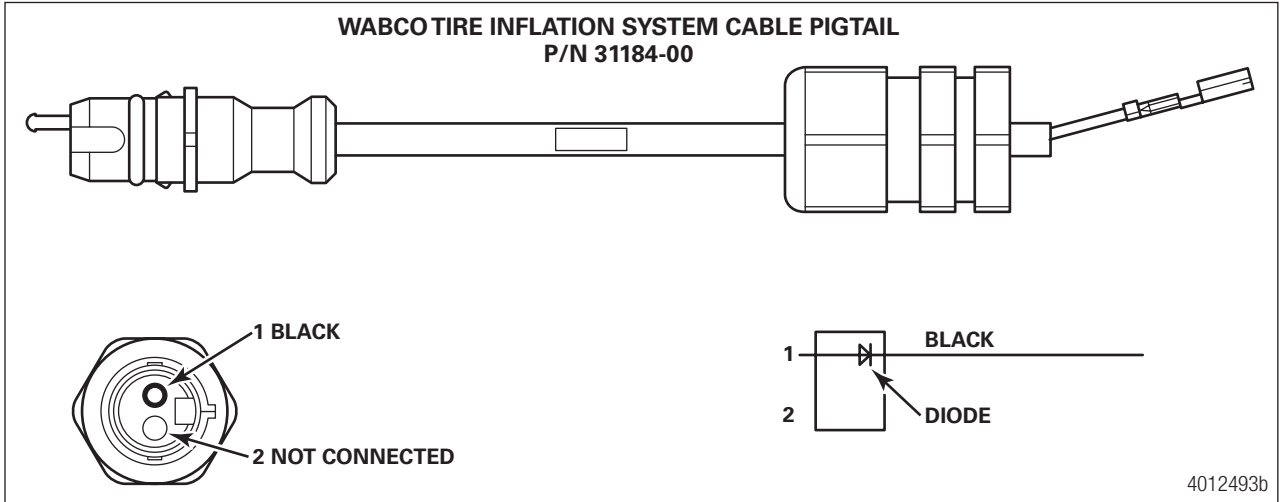
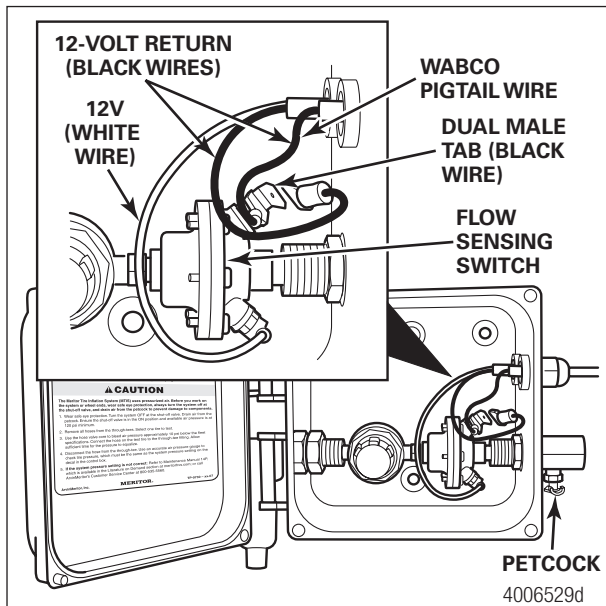
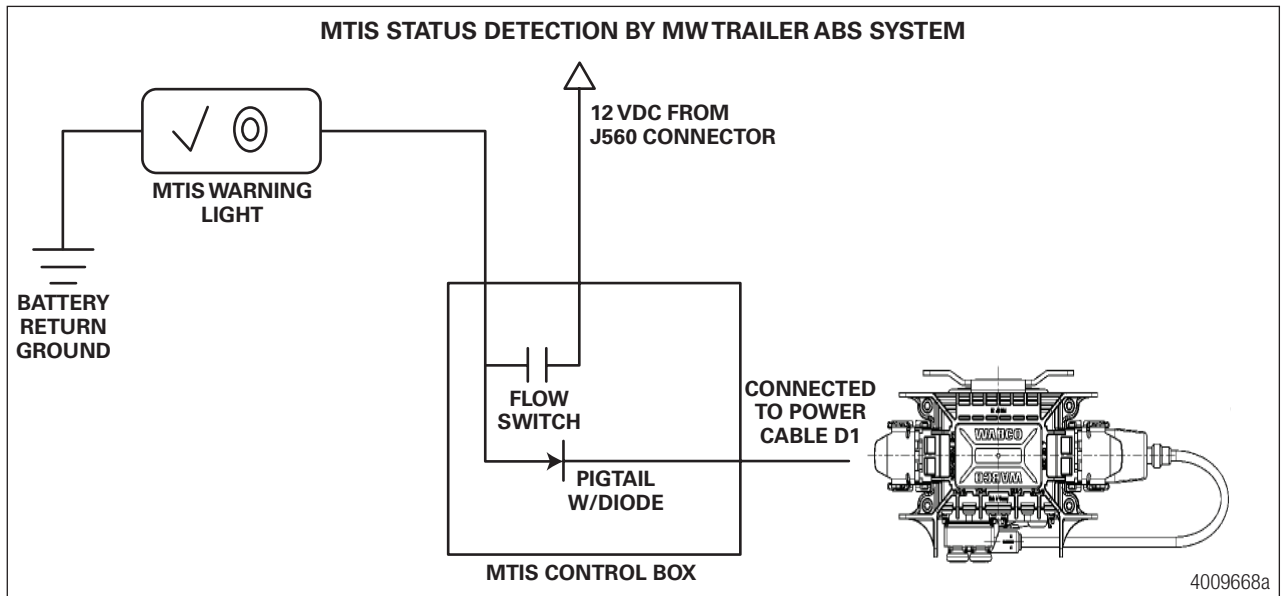

Fig. 9.31



Troubleshooting

Fig. 9.32



9.5 Door Ajar System Troubleshooting – Trailer ABS



ECU part numbers 480 500 105 0 and 400 500 106 0 are the only trailer ABS valve that has Door Ajar System functionality.

The first step taken when troubleshooting the Door Ajar System is to ensure that the system electrical cables are connected correctly. Refer to Figure 9.33 and Figure 9.34 in this section for parts and the correct schematic, depending upon the configuration.

For additional information, refer to TP17133, Installing and Configuring the WABCO Trailer ABS with Tire Inflation and Door Ajar Systems, found at zf.com/cvliterature.

This troubleshooting section is based on the use of TOOLBOX PLUS™ Software version 12.5 or higher. If you have an earlier version of TOOLBOX PLUS™ Software, visit <https://wabco.snapon.com/> or contact your Snap-On dealer.

Troubleshooting

| Condition Experienced | Action to Take | Troubleshooting Details |
|--|---|---|
| Door ajar system is not broadcasting a "Door Ajar" message when the trailer door is open | Correct installation needs to be verified | Confirm WABCO Door Ajar System is installed per Figs. 9.33, 9.34 and 9.35. Make sure all electrical connections are fully seated. |
| | ECU valve should audibly click during its power-up self-test. | Ensure that 12 volts is present across pin1 and pin 4 on the ECU power connector. |
| | Check continuity of the I/O cable. | Check continuity for the 449 442 XXX 0 generic I/O cable. |
| | Check proximity switch part number 446 147 XXX 4. | A volt/ohm meter must be used to check the proximity switch, part number 446 147 XXX 4. Make sure the ohm meter shows more than 1 M when magnets are actuated (access point is closed) and less than 1 when access point is open. Also the gap between the mating connector to enable correct NO NC contact should be less than 2.5 inches (64 mm). |
| | Confirm Door Ajar system has been activated in the ECU. | From the Trailer ABS portion of the TOOLBOX PLUS™ Software, select the System pull-down. Select Edit Parameters from ECU. Press the Next button. Ensure the box next to Door Ajar System is checked. Press Close and then exit the TOOLBOX PLUS™ Software. If the Door Ajar is not checked, proceed to Activating the Door Ajar System in this section. |
| "Door Ajar" message is being broadcasted all the time | Correct installation needs to be verified. | Confirm WABCO Door Ajar System is installed per Figs. 9.33, 9.34 and 9.35. Make sure all electrical connections are fully seated. |
| "Door Ajar" message is not broadcasted on the telematics display | Contact the telematics provider. | Since WABCO does not provide telematics unit, please contact the telematics provider. |
| The Parameter File "Tire inflation & Door ajar.tio" has been successfully downloaded to the ECU, but Door Ajar system message is not being broadcasted | Confirm „Tire inflation & Door Ajar.tio“ is visible in the "Notebook" section of TOOLBOX PLUS™ Software 12.2 or higher. | Call the WABCO Customer Care Center at 855-228-3203. |

Troubleshooting

Fig. 9.33

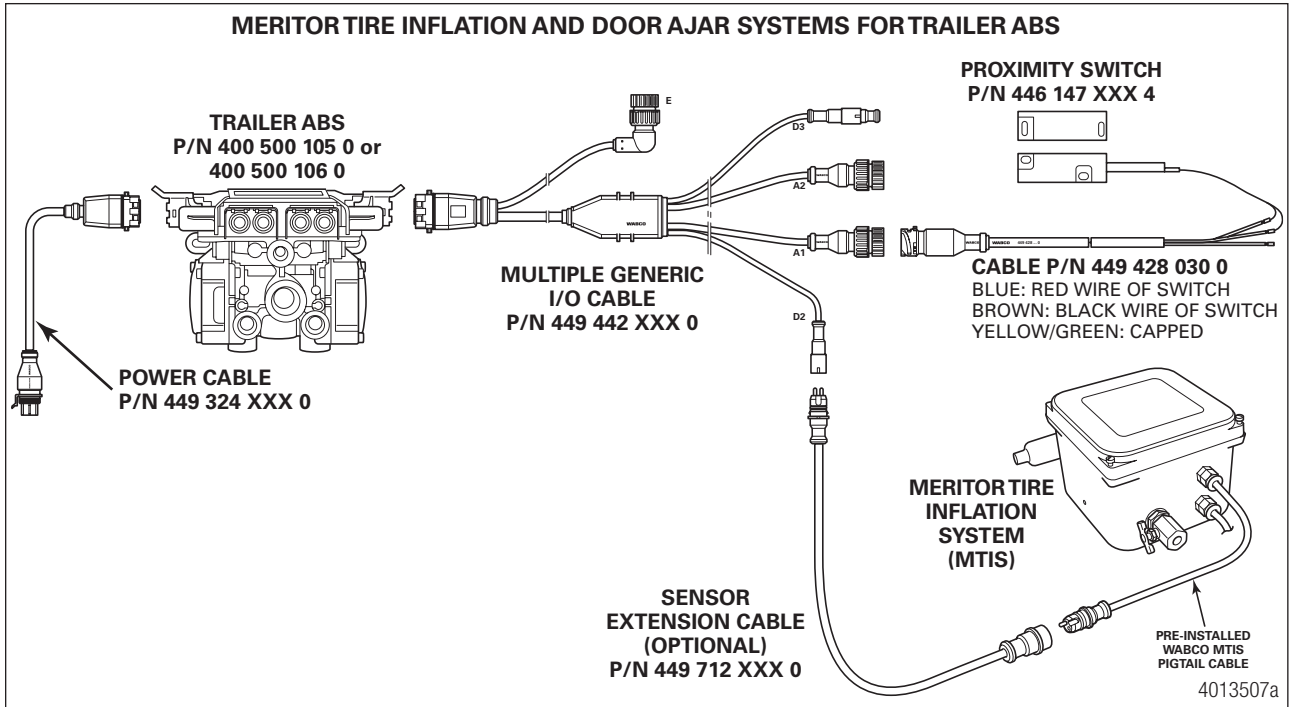
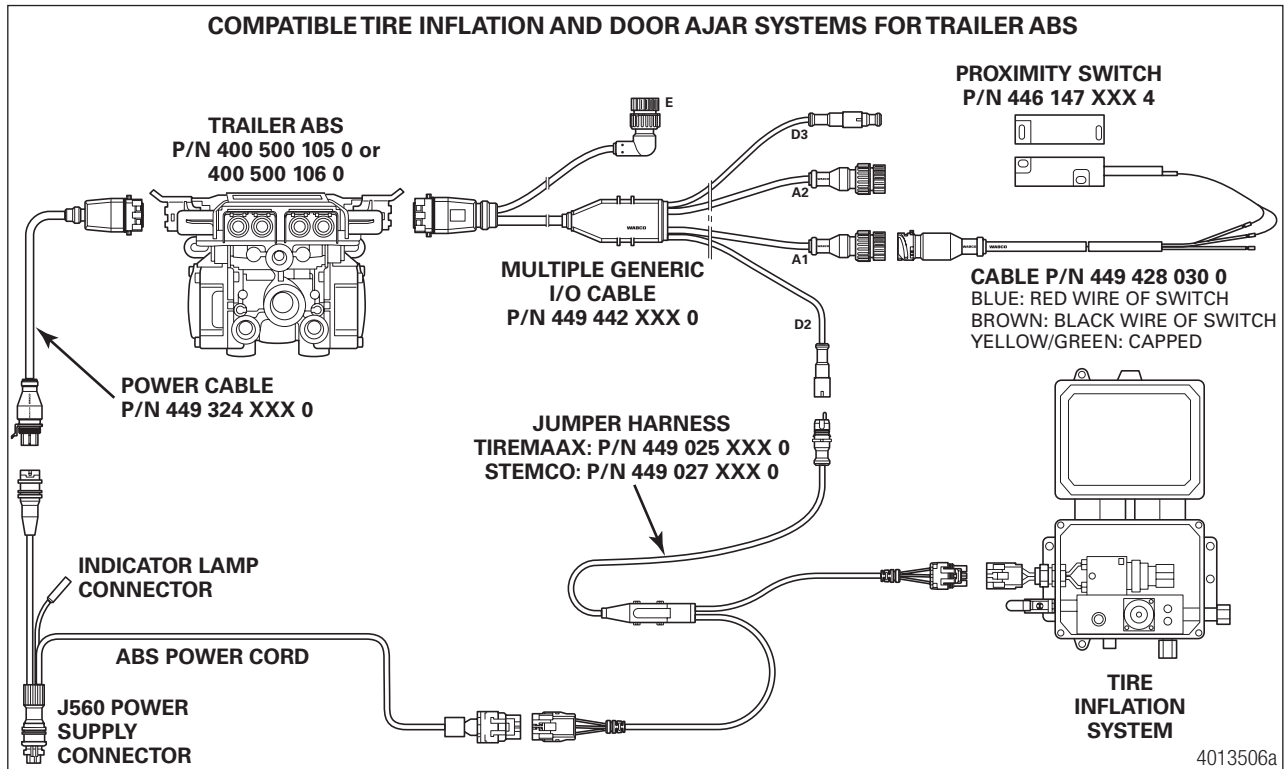
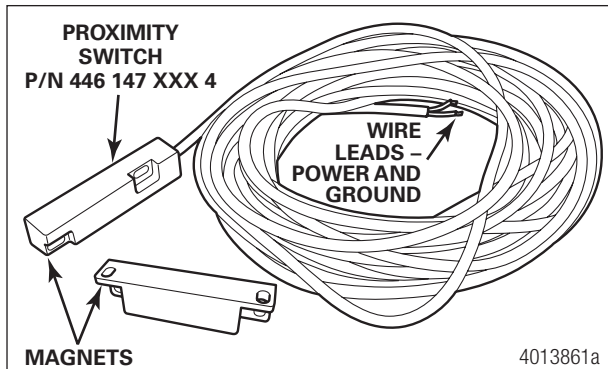

Fig. 9.34



Troubleshooting

Fig. 9.35



9.6 Activating the Tire Inflation and Door Ajar Systems Option with TOOLBOX PLUS™ Software

Once the hardware has been installed, both the Tire Inflation and Door Ajar Systems options must be activated using WABCO TOOLBOX PLUS™ Software version 12.2 or higher. When installing Tire Inflation and Door Ajar Systems option on new or replacement ECUs, the activation process is part of the normal programming procedure.

1. Click the **TOOLBOX** icon on the desktop and then click the J1708/PLC icon.

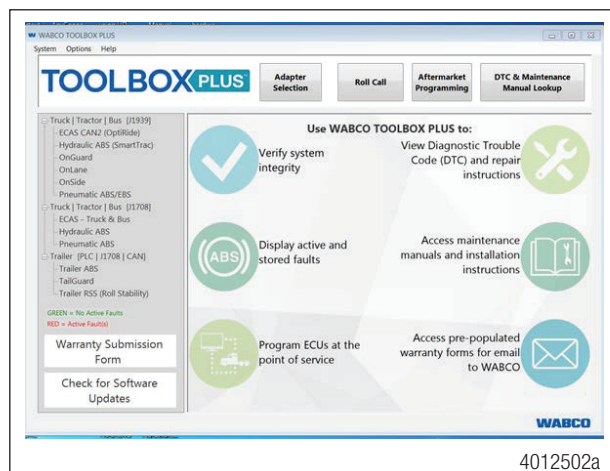

2. Click on the Trailer ABS Diagnostics icon to initiate the ABS portion of TOOLBOX PLUS™ Software.

Troubleshooting

i To enable trailer and TOOLBOX PLUS™ Software communication, make sure the correct adapter is selected under System Setup tab.

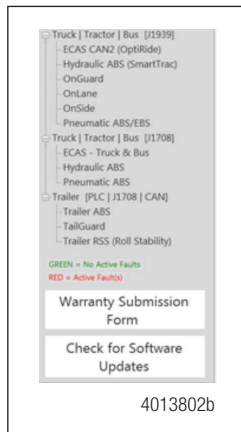

3. From the top menu bar, go to the Modify pull-down menu and select GIO Configuration.

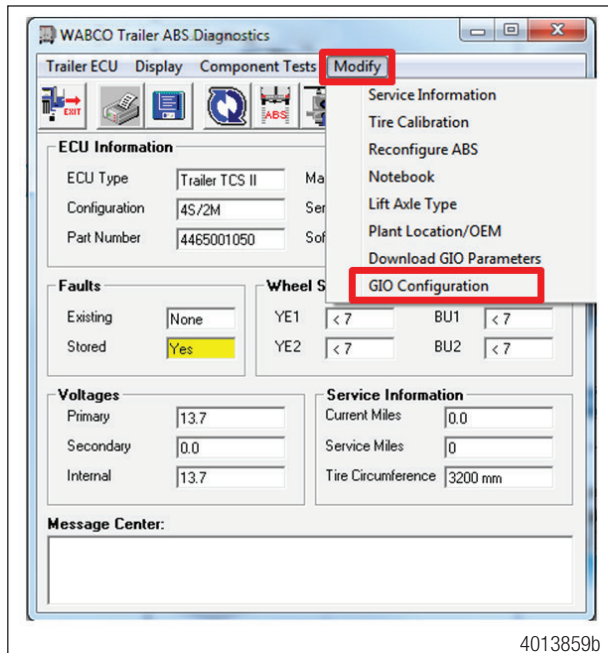

Troubleshooting

- When the GIO Configuration screen is displayed, click the Tire Inflation and Door Ajar radial button. Ensure that a circle appears in the box. Then, press the Download button at the bottom of the screen.

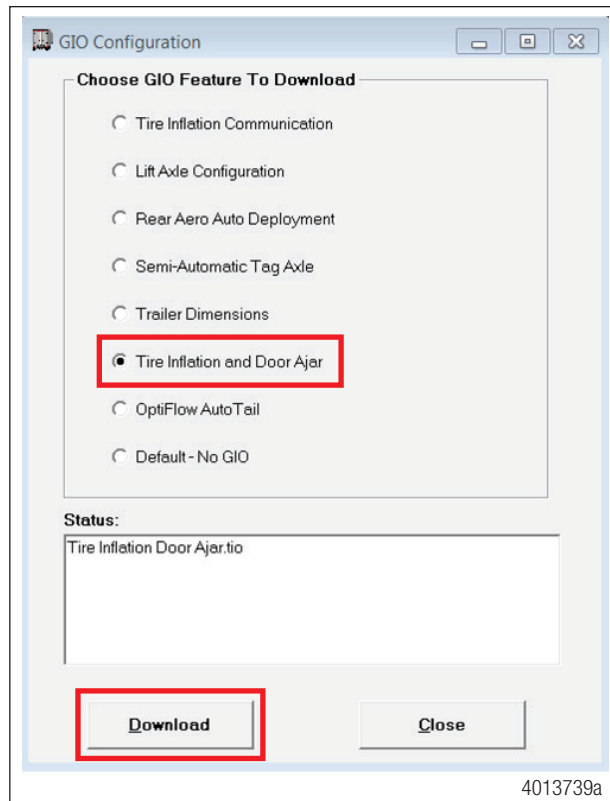

- Once a message is displayed confirming a successful save, click **Exit** in the main screen to close the TOOLBOX PLUS™ Software.
- Cycle the power on the trailer in order to reset the ECU.

Appendix I

10 Appendix I

10.1 Trailer ABS Indicator Lamp on Vehicle Dash

The trailer ABS indicator lamp on vehicle dash applies to Trailer ABS only. The lamp is controlled by a signal to the tractor ECU, which is sent over the power line (PLC function). When a trailer ABS fault is detected, an ON message is sent. When no fault is detected, the ECU receives an OFF message

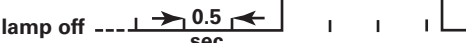

Table C illustrates trailer ABS lamp operation at power-up or ignition on. Table D depicts lamp responses that occur during operation.

Lamp turn ON and OFF messages do not turn the lamp ON or OFF instantly. The delay between the receipt of the message and the lamp response time is intentional, because it prevents erratic lamp activity.



For doubles or triples, the lamp does not distinguish between trailers. A system fault in any of the trailers will activate the trailer ABS indicator lamp.

TABLE C: DASH-MOUNTED TRAILER ABS INDICATOR LAMP OPERATION — BULB CHECK (INFORMATION FOR DRIVERS)

| Signal from trailer to tractor ECU | Status of Trailer ABS Lamp on vehicle dash | Explanation |
|---|--|---|
| <p>Single or Multiple Trailers</p> <p>message OFF OFF OFF OFF OFF OFF OFF</p> <p>lamp on ...</p> <p>lamp off </p> | <p>Trailer ABS lamp comes on at ignition, OFF message is detected within three seconds of ignition, Trailer ABS lamp goes out.</p> | <p>Bulb Check performed AND Trailer ABS system is OK. In this case, the lamp is ON for a Bulb Check only.</p> |
| <p>Single or Multiple Trailers</p> <p>message No ON or OFF messages</p> <p>lamp on OFF OFF ..</p> <p>lamp off </p> | <p>Trailer ABS lamp does not come on within three seconds of ignition.</p> | <p>No Bulb Check, trailer added after initial power-up, system OK. There was no trailer PLC message for at least three seconds following ignition ON.</p> |







ON = Turn ON message to “trailer ABS” lamp

OFF = Turn OFF message to “trailer ABS” lamp

Removing a trailer with a fault will cause ABS lamp to turn off. Remember to have trailer with fault repaired as soon as possible before returning to service.

Appendix I

**TABLE D: DASH-MOUNTED TRAILER ABS INDICATOR LAMP OPERATION
(INFORMATION FOR SERVICE TECHNICIANS)**

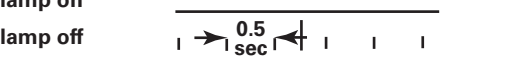
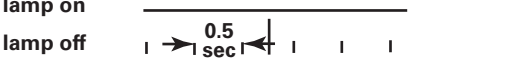
| Signal from trailer to tractor ECU | Status of Trailer ABS Lamp on vehicle dash | Explanation | Action |
|--|---|---|---|
| Single or Multiple Trailers message No ON or OFF messages lamp on lamp off  | Trailer ABS lamp does not come on within three seconds of ignition. | Not using the PLC system (no trailer connected) or trailer not equipped with PLC or fault in PLC system. | Use lamp on side of trailer to identify fault. Make necessary repairs. |
| Single Trailer message OFF OFF OFF ON ON ON ON ON lamp on  | Trailer ABS lamp comes on. | Trailer ABS fault(s) occurred during operation and still exists. | |
| Multiple Trailers/Dollies message OFF OFF OFF OFF OFF OFF OFF OFF OFF OFF OFF ON ON ON ON lamp on  | | | |
| Single Trailer message ON ON OFF OFF OFF OFF OFF OFF lamp on  | Trailer ABS lamp comes on but goes out after 2.5 seconds after fault is detected. | Trailer ABS fault occurred during operation and the fault was corrected. | None |
| Multiple Trailers/Dollies message OFF OFF OFF OFF OFF OFF OFF OFF ON ON OFF OFF OFF OFF OFF OFF lamp on  | | | |
| Single Trailer message ON ON ON No ON or OFF messages lamp on  | ABS lamp is off, comes on, then goes off, 10 seconds after loss of messages. | ABS fault existed, then signal was lost because trailer disconnected or PLC fault. | Use lamp on side of trailer to identify fault. Make necessary repairs. |
| Multiple Trailers/Dollies message OFF OFF OFF OFF OFF OFF OFF OFF ON ON lamp on  | | | |
| Single Trailer to Multiples message ON ON ON ON ON ON OFF OFF OFF lamp on  | ABS lamp is on and stays on when a new trailer with no new fault is added. | There was a fault in existence before the new trailer was added AND the ignition was not turned off before the trailer was added. | |
| Single Trailer to Multiples message ON ON ON ON ON ON ON ON lamp on  | | | ABS lamp is on and stays on when a new trailer with a new fault is added. |

ON = Turn ON message to “trailer ABS” lamp

OFF = Turn OFF message to “trailer ABS” lamp

Removing a trailer with a fault will cause ABS lamp to turn off. Remember to have trailer with fault repaired as soon as possible before returning to service. To attach the valve to the ECU, tighten the four hex bolts to 5 lb-ft (6 N•m).

Appendix II

11 Appendix II

11.1 Cable Routing Guideline

All wires should be tightly secured to a solid member in intervals not greater than 18-inches (457 mm) to avoid excess cable vibration and potential snags with road debris. The correct cable installation should not allow the cable to slide through beam clamps/zip ties, but not tight enough to pinch the internal wires. Refer to technical bulletins TP20212 and TP1593 for more information.

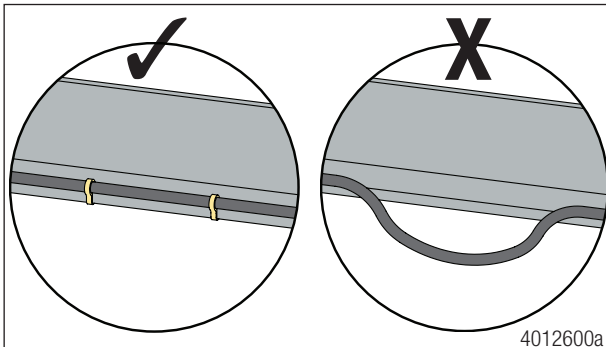

Wiring should NEVER go through any bare, unprotected metal holes. Use grommets, caulk or wire wrap to protect wire from premature.

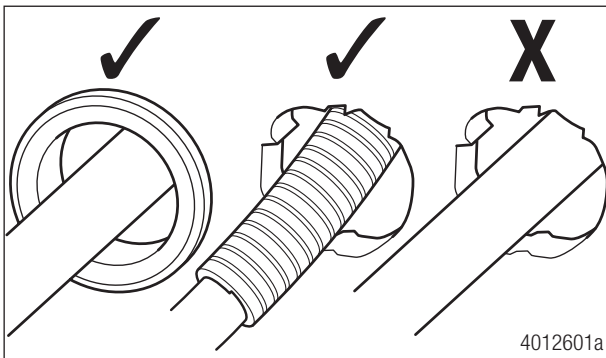

When routing the cable through the wiring channel on the edge or center of the trailer, secure the shorter leg of the latch connectors to the longer leg to ease wire routing.

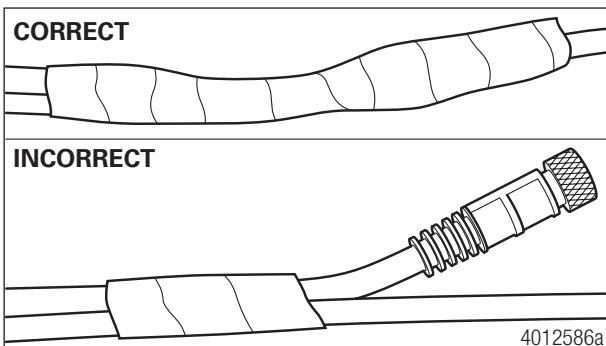

Appendix II

When using a wire snake to pull the cable up through the frame, make sure to tape the connectors correctly to the wire snake.

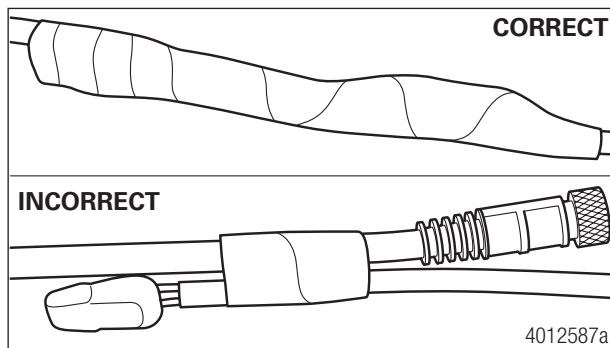

11.2 Cable Strain Relief Guidelines

It is important that cabling follows good strain relief practices to ensure maximum performance and durability. Failure to provide adequate strain relief on the cables can result in future maintenance that is not covered under warranty.

Strain relief is defined as a small amount of slack in the cable at the area of connection. This lack of cable tension allows for slight movement of the cable during times when components of the suspension and air system are in motion. A small amount of slack also eases access to other system components.

A taut cable can negatively affect the lifespan of the cable and attached component. Cables without adequate strain relief can potentially stress a cable connection enough that moisture could intrude into the cable connector. Internal wire stress at bend points can be the result of a cable under tension.

Cable strain relief is a universal practice. It applies to all WABCO product lines from Anti-Lock Brake (ABS) systems to Roll Stability Systems (RSS).

11.2.1 Excess Cable Length

In cases where the length of cable exceeds what is required, the excess must be bundled in an efficient manner.

- Cables should not be draped or wrapped around components or left unsecured.
- All slack remaining in the cable once the connections are made can be bundled in a Z-shaped loop. Do not coil the cable into a circular bundle.
- The bend at the end of the bundled cable should be greater than or equal to ten times the diameter of the cable.
- All cable fasteners should be tightened in a manner only to the extent that the cable is held sufficiently in place. Over tightening can result in damage to the cable.
- Fasten the excess cable to an area that is free of sharp edges and moving components.

WABCO has many lengths of cables available so it is a best practice to obtain a length that suits the requirements of the installation.

Appendix II

11.2.2 Strain Relief at the ECU – Bracket Mounting

It is recommended that cable connections to a component, such as an ECU valve assembly, display a visible amount of slack in the cable up to the first fastener, that secures the cable to trailer structure or air line. This applies to both zip ties or cable clips. This first anchor point should be a minimum 6-inches and a maximum 12-inches of cable length from the cable/component connection. This applies to all sensor, power, valve and GIO cables. Regardless of whether zip ties or cable clips are used, cables should be secured at intervals of a maximum of 18-inches to avoid cable vibration or excess cable that could potentially snag with external objects.

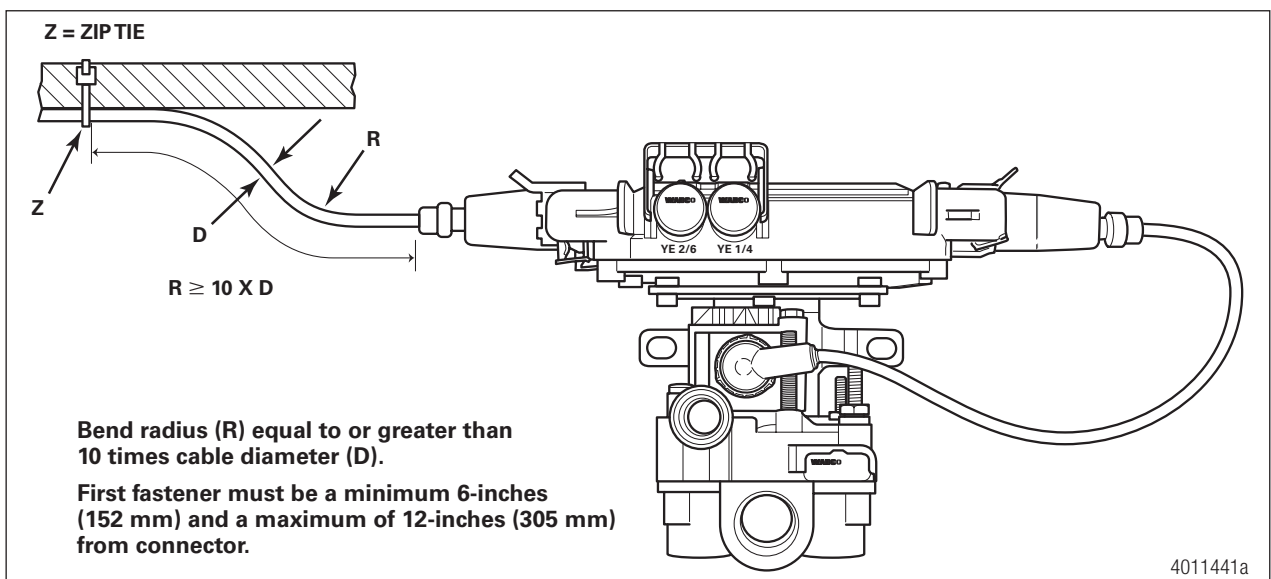
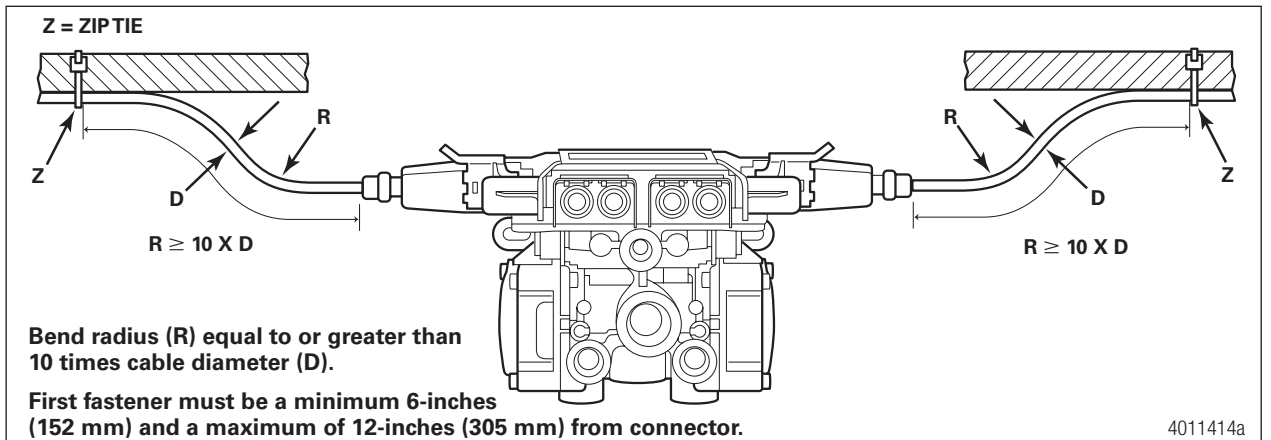

Appendix II

11.2.3 Strain Relief at the ECU – Tank Mounting

It is necessary that cable connections to a component, such as an ECU valve assembly, display a visible amount of slack in the cable up to the first tie or clip that secures the cable to trailer structure or air line. This first anchor point should be a minimum 6-inches of cable length from the cable/component connection. This applies to all sensor, power, valve and GIO cables. Regardless of whether zip ties or cable clips are used, cables should be secured at intervals not greater than 18-inches to avoid cable vibration or excess cable that could potentially snag with external objects.

Ideally, cables should be affixed to the rigid structure of the trailer. However, structure is not always available on tank-mounted installations. In these cases, securing the cable may be accomplished by fastening the cable to nearby air lines. It is important to note that cables should be secured only to the extent that the cable is held sufficiently in place. Over tightening can damage the cable or the air line.

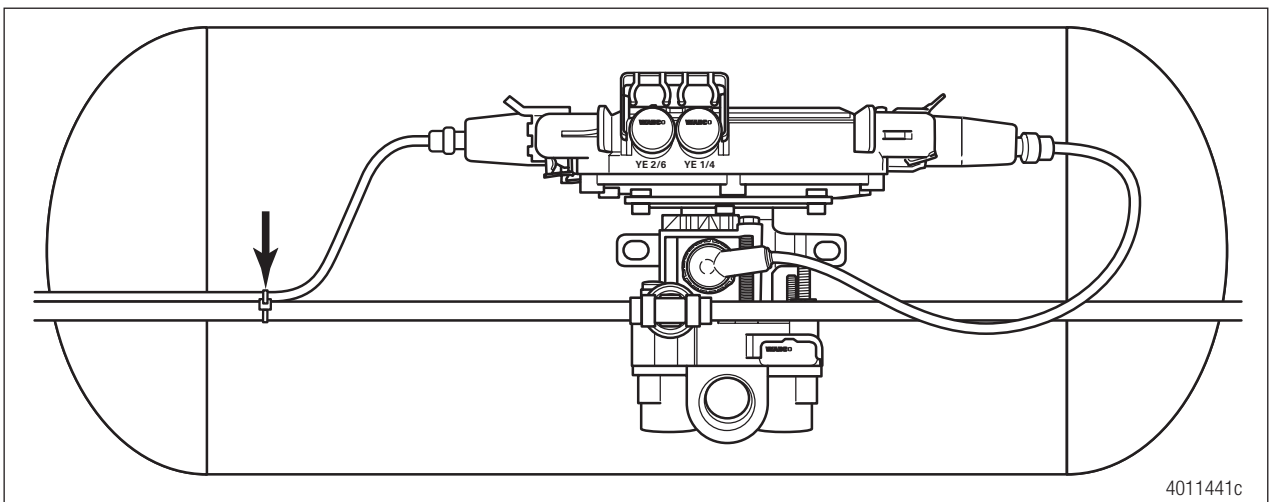
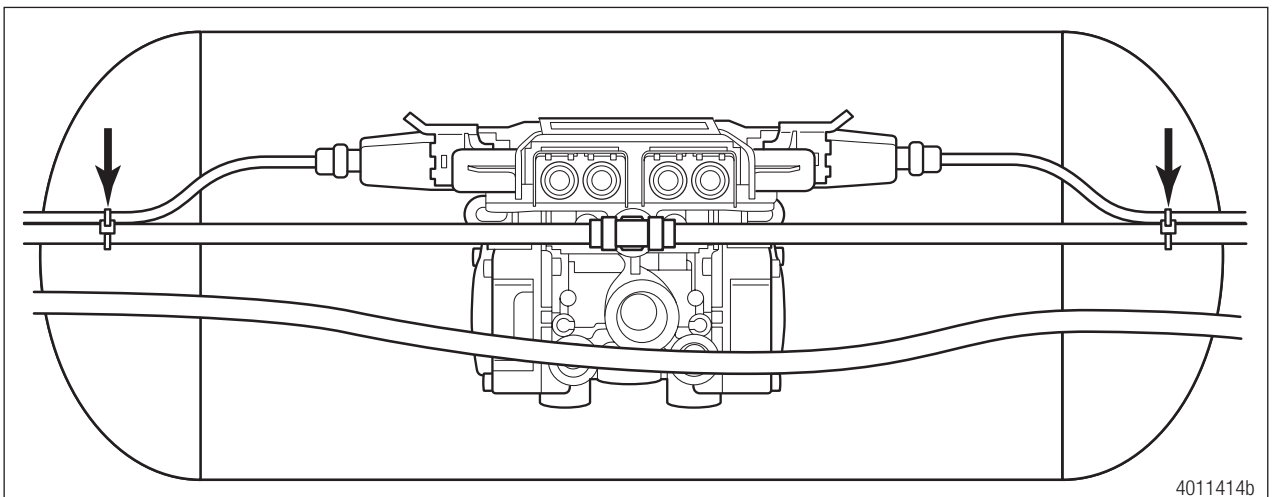

Appendix II

11.2.4 Sensor Extension Cables at the ECU

On valves that are tank mounted or remote mounted with no trailer structure nearby, cables are attached to the brake delivery air lines. Cable clips are preferred to zip ties. In order to avoid damage to the wires, it is important that cables should be fastened in a manner where the cable is secured only to a point where the cable will not move or chafe against what it is mounted to. A small amount of slack should be present to ensure that the cables are not taut after installation or the servicing of components. Examples are shown.

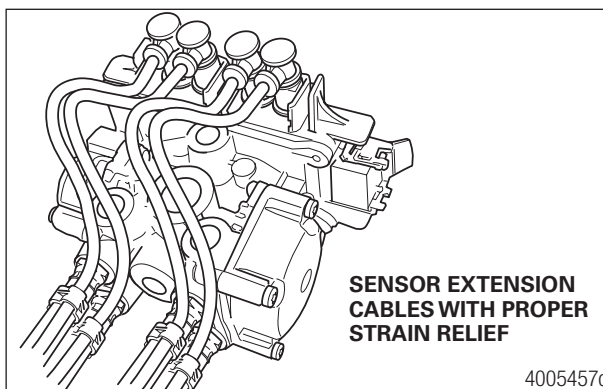
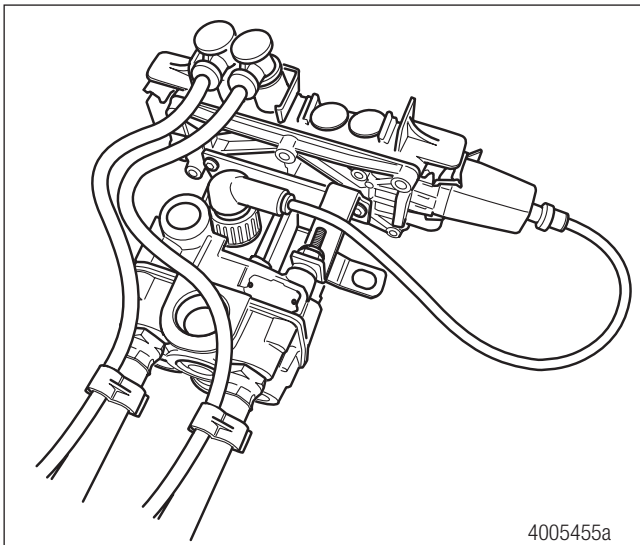

11.2.5 Securing WABCO Cables to Air Lines

Routing of cables near the ECU assembly and attached to air lines requires careful consideration. Care should be taken that cable fasteners are not over tightened on either the air line or the cable. The cables should be anchored only tight enough to prevent movement of the cable without pinching the air line.

Selection of the optimum fitting also has an impact of strain relief. Ensure that cables are not pinched, bent or wrapped around any fittings in the cable proximity.

Appendix II

11.2.6 Connection of Cables

It is important to ensure all cable-to-cable connections maintain correct strain relief. Cable restraints must be placed between two- and four-inches from the cable connector to ensure correct strain relief. Regardless of whether zip ties or cable clips are used, cables should be secured at intervals of a maximum of 18-inches to avoid cable vibration.

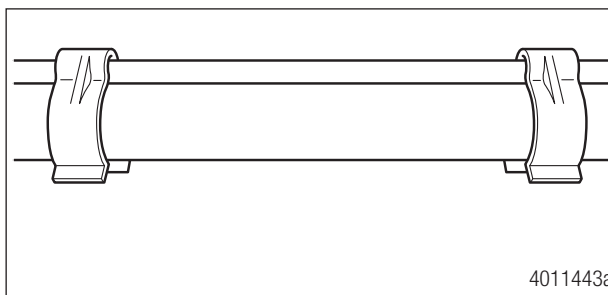
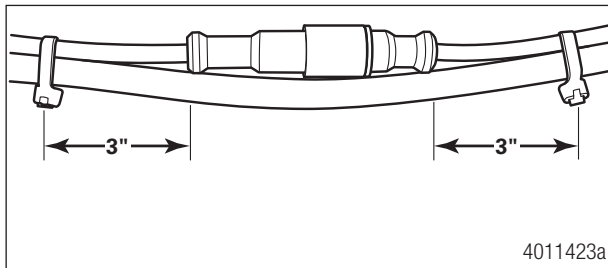
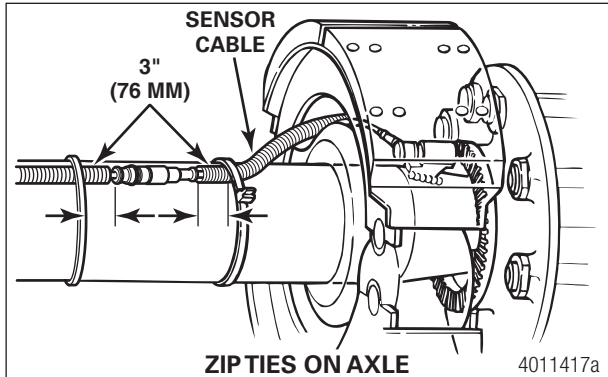

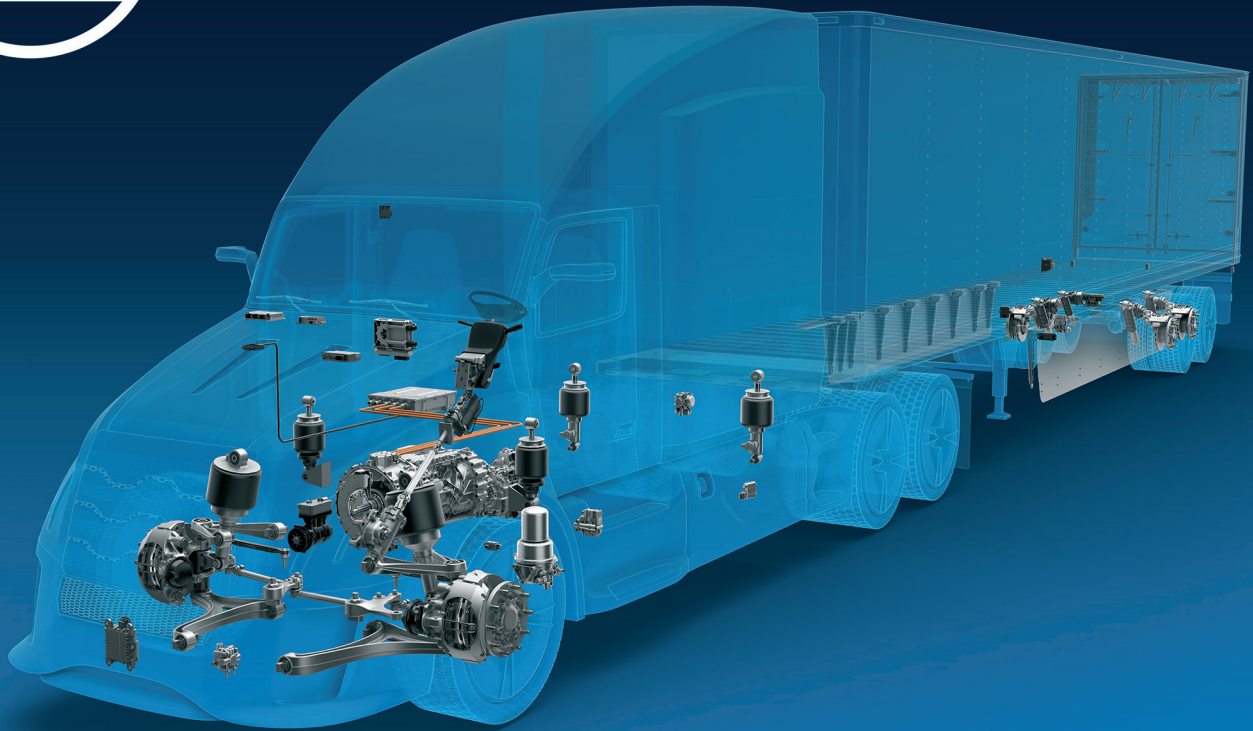

For further details, contact the
WABCO Customer Care Center at 855-228-3203.

About CVS Division

ZF's Commercial Vehicle Solutions (CVS) division is helping shape the future of commercial transportation ecosystems. Our mission is to be the preferred global technology partner to the commercial vehicle industry. Powerfully combining ZF's commercial vehicle systems expertise, extensive technology portfolio and global operations, the division serves the full commercial vehicle industry value chain. As the automotive industry progresses towards an increasingly autonomous, connected, and electrified (ACE) future, ZF's CVS division innovates, integrates and supplies components and advanced control systems that help make commercial vehicles and fleets operate more safely and sustainably. CVS unites ZF's former Commercial Vehicle Technology and Commercial Vehicle Control Systems divisions, the latter being formed following ZF's acquisition of WABCO in Spring 2020.

For more information, visit: www.zf.com/cv

WABCO