

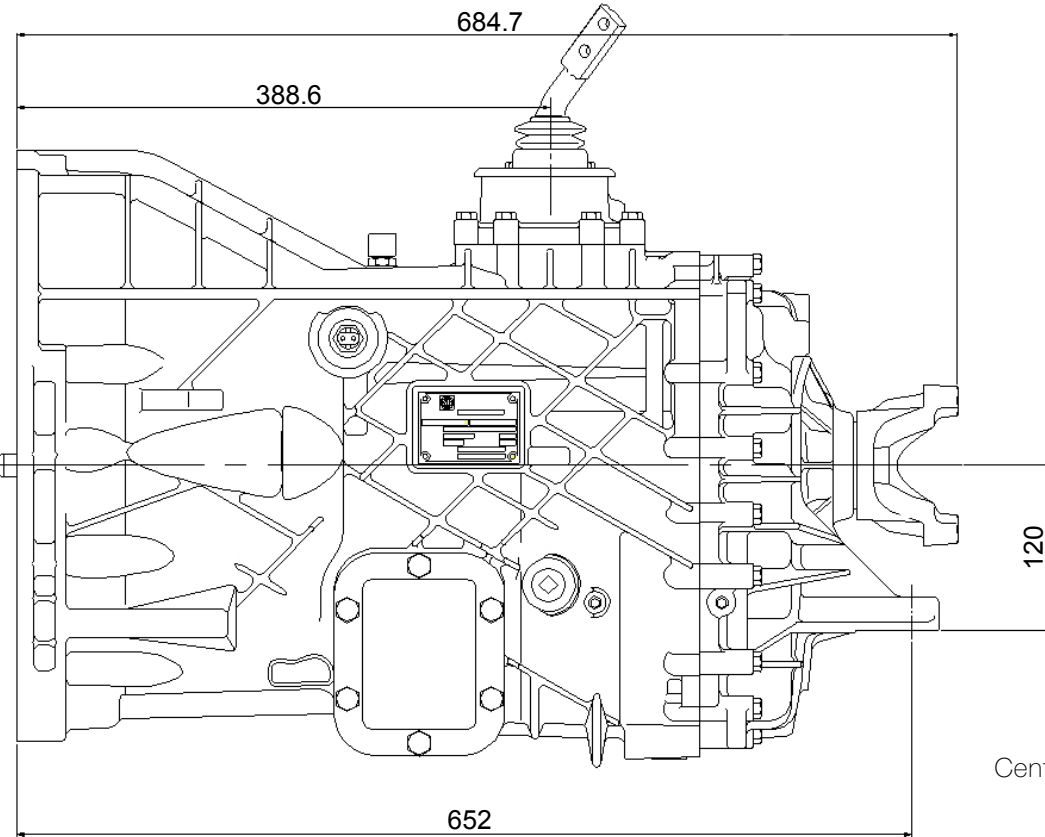

# ZF S 5-47 Synchromesh Gearbox

FOR LIGHT COMMERCIAL VEHICLES



## Shift Pattern

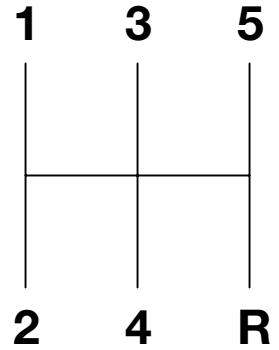

Center Distance = 105 mm

The ZF S 5-47 synchromesh gearbox was developed for light and medium duty trucks with a GCW of up to 11.800 Kg.

### Product Characteristics:

- Synchronized in all gears
- High power to weight ratio
- Direct or remote shift option
- Tight shift pattern
- Aluminum housing (front and rear)

### Installation Options:

- SAE or special clutch housings
- Integrated or bolt-on bell housing
- Left and right ISO/SAE 6 bolt PTO
- Output flange or yoke\*
- 4WD or 2WD capability

| Input Torque **<br>(Nm) | 1st Gear | 2nd Gear | 3rd Gear | 4th Gear | 5th Gear | Reverse Gear | Dry Weight (Kg) | Oil Quantity (L) |
|-------------------------|----------|----------|----------|----------|----------|--------------|-----------------|------------------|
|                         | 640      | 5,72     | 2,94     | 1,61     | 1,00     | 0,76         |                 |                  |
|                         | 5,08     | 2,61     | 1,53     | 1,00     | 0,77     | 4,66         |                 |                  |
|                         | 4,14     | 2,37     | 1,42     | 1,00     | 0,77     | 3,79         |                 |                  |

\* Yoke available in SAE Series 1330, 1350, 1410, 1480

\*\* Reference value; depending on vehicle application data

