

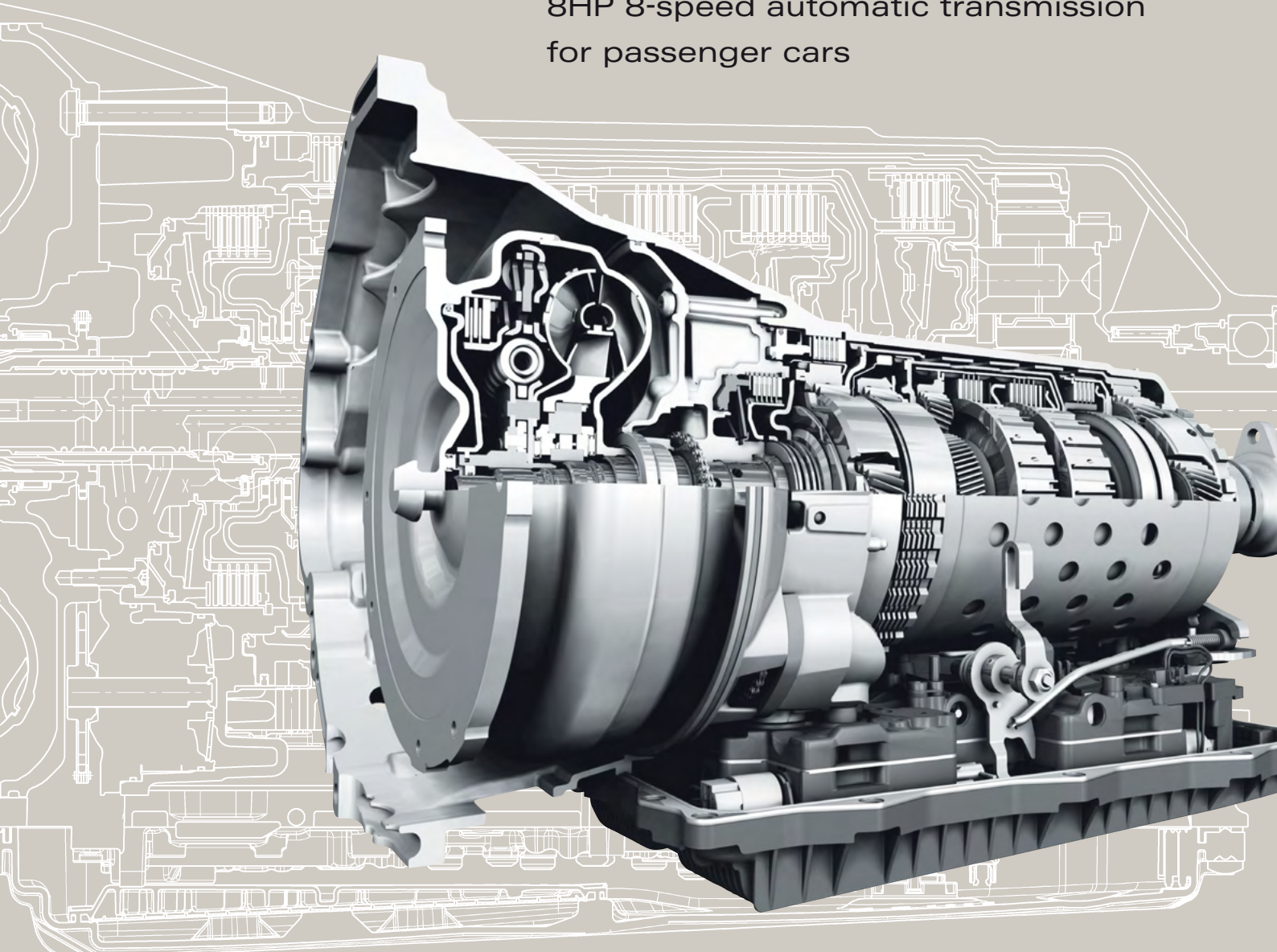

The perfect increase in efficiency



8HP 8-speed automatic transmission
for passenger cars



Innovation by reduction: efficiency, perfected

The new 8HP 8-speed automatic transmission, which was designed to be more lightweight, sets new standards for flexibility, efficiency, and economy. It is an excellent example of how the power of innovation can create a new classic design.

A torque range from 300 to 1000 Nm makes the 8HP the perfect partner for all rear-wheel-drive and all-wheel-drive designs. From the lower midsize segment to sporty

luxury cars, and in every type of SUV and off-road vehicle – its revolutionary design is always an efficient and economical solution.

Although the 8HP features 2 more speeds than the extremely successful 6HP, the dimensions have remained unchanged and the weight was even reduced by 3 percent to 89 kg (196 lbs.) including oil.

At the same time, the total transmission ratio spread of 7.0 ensures that the engine is always in its optimum operating range. This translates into improved acceleration and reduced fuel consumption.

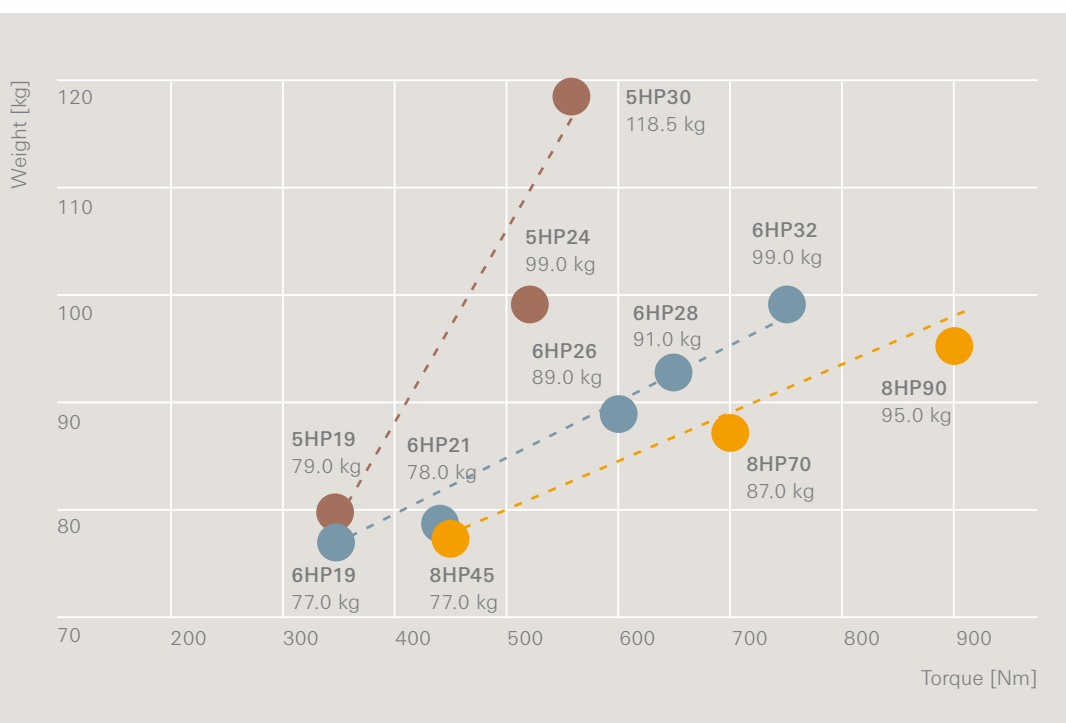

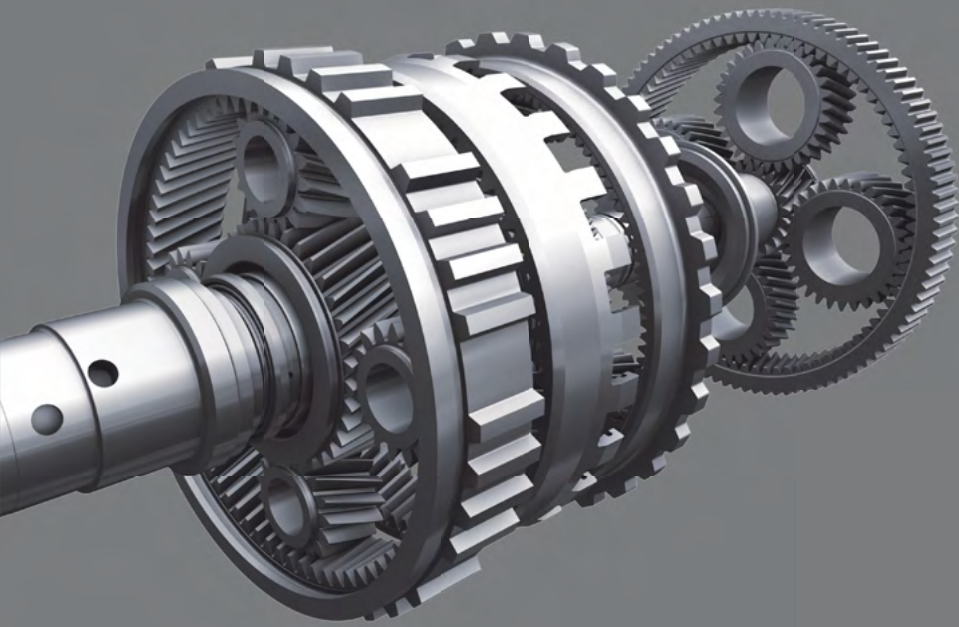

Clutch

Brakes

Torque converter with torsional vibration damper

Gearset 4

Gearsets 1 to 3

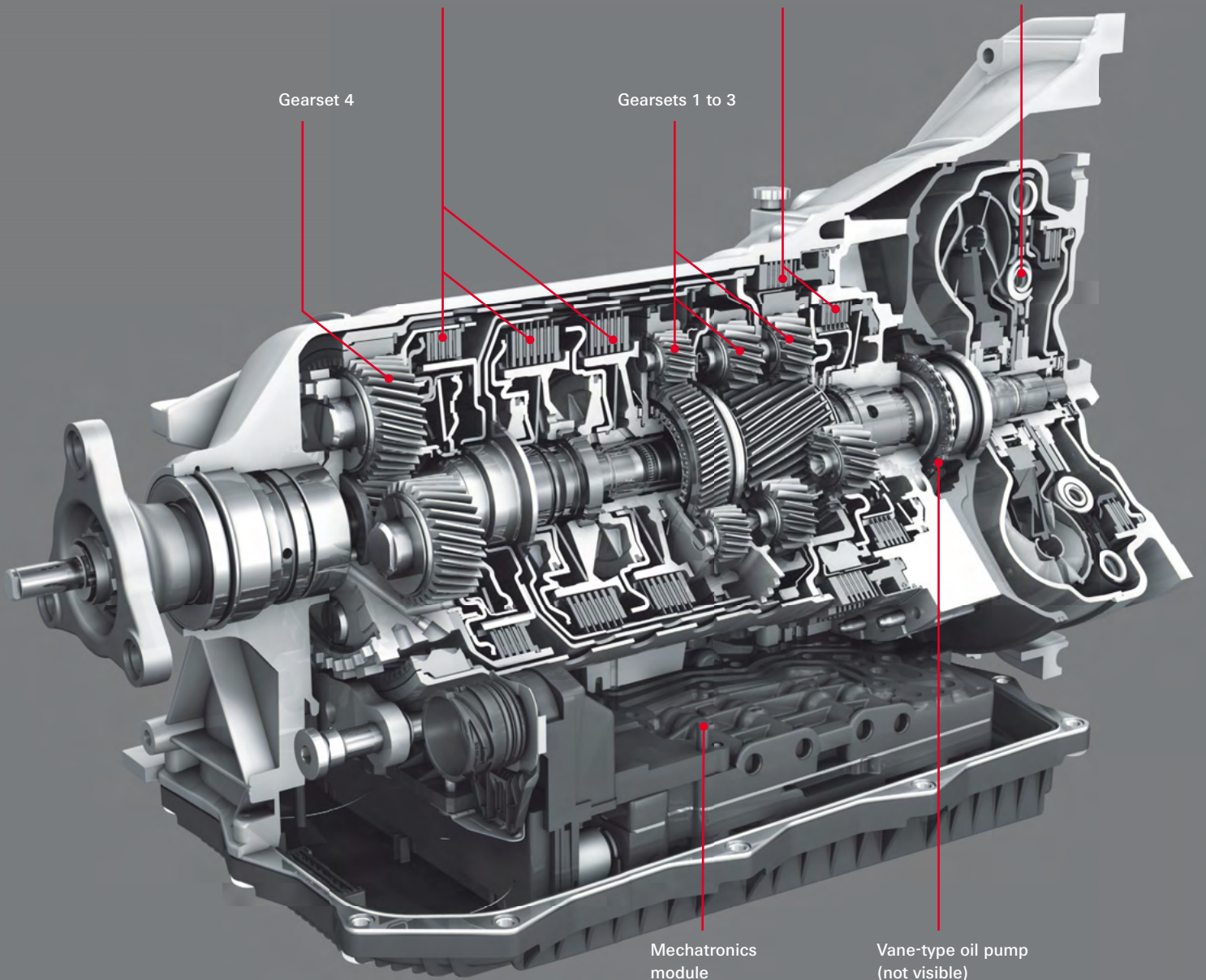

Mechatronics module

Vane-type oil pump (not visible)

Unbeatably flexible: our modular construction system

For the 8-speed automatic transmission, ZF set out to design and develop an entirely new gear set concept. The result is a revolution in transmission design: a transmission concept with 4 gearsets which requires only 5 shift elements – of which only two are open in any given gear.

The 8HP also requires no more than 3 multi-disk clutches and 2 brakes, which allows it to achieve a greater degree of efficiency than other concepts. As a result of the fact that only 2 shift elements are open per gear, drag losses in the transmission are sustainably reduced. This effect is supported by the use of a new parallel-axis vane-type oil pump.

The flexible modular construction system of the 8HP is full of innovations and is well-suited to serve as the basis for a wide range of future development possibilities. The following technologies can be implemented without altering the transmission installation space:

- Hydrodynamically cooled clutch
- Integrated starting clutch
- Crankshaft starter generator
- Integrated hybrid

As a future-proof transmission, the 8HP is also compatible with the following all-wheel-drive concepts:

- All-wheel drive center differential integrated
- Integrated all-wheel drive system (IAS®)
- Hang-on all-wheel-drive

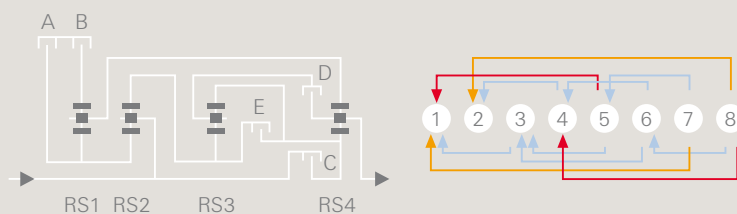

1	●	●	●			4.70	1.50
2	●	●			●	3.13	1.49
3		●	●		●	2.10	1.26
4		●		●	●	1.67	1.30
5		●	●	●	●	1.29	1.29
6			●	●	●	1.00	1.19
7	●		●	●	●	0.84	1.25
8	●			●	●	0.67	
R	●	●		●		-3.30	Spread 7.05
	A	B	C	D	E		
Gear	Brake		Clutch			Ratio	Gear step

Transmission system

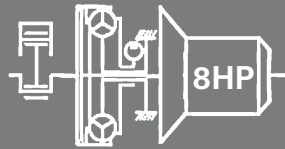

Base transmission with torque converter

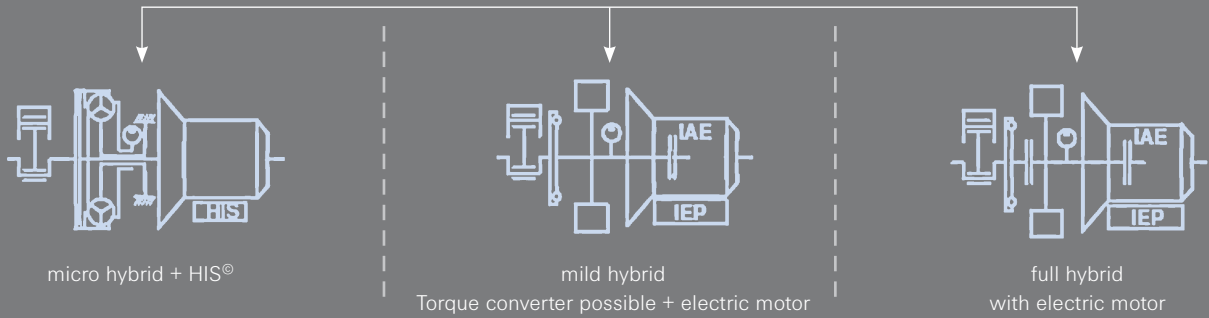

Modular hybrid construction system for 8HP

HIS: Hydraulic Impuls Storage (HIS[®])

IAE: Integrated starting element

IEP: Integrated electric pump

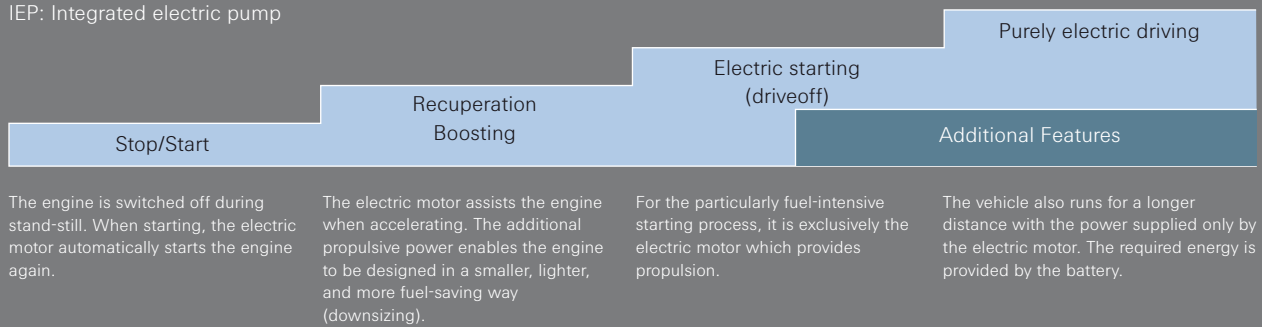

8HP (for longitudinal installation)

300-1.000 Nm, for gasoline or diesel engines

Fuel Savings*

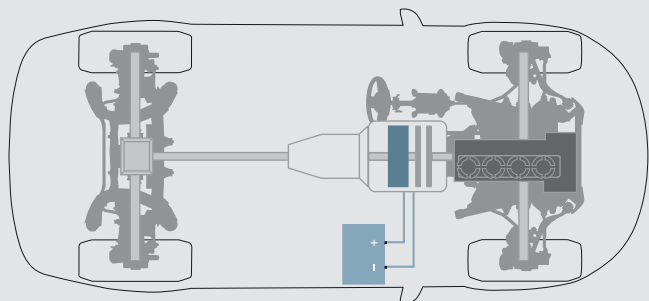
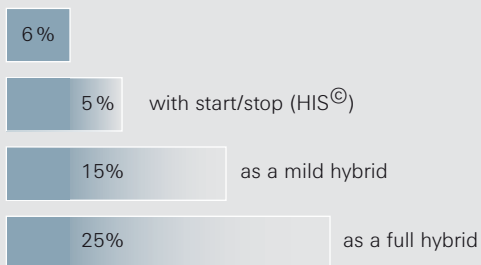

Vehicle classes

Standard and all-wheel drives

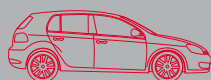

Compact vehicle class

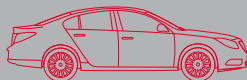

Mid-size class/full-size vehicle class

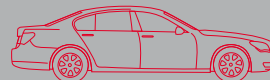

Luxury vehicle class

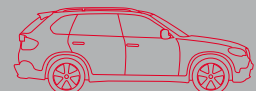

SUVs/Pickups

* Compared with the 2nd-generation 6HP 6-speed automatic transmission in the NEDC

Sustainable concept for the powertrains of the future

The 8-speed automatic transmission reduces overall fuel consumption by at least 6 % compared to present state of the art 2nd Generation ZF 6-speed automatic transmissions. As an example, the CO₂ emissions of a six-cylinder engine with a displacement of 2.5 liters can be reduced from 180 g/km to 169 g/km. An important contribution to this reduction is provided by the increasingly popular engine start/stop function, which automatically

shuts off the engine when the vehicle comes to a stop and immediately re-activates the engine and transmission when the footbrake is released.

The flexibility of the 8HP makes it a future-proof partner for even more sustainable powertrain concepts such as hybrid solutions. In a full-hybrid vehicle, the 8HP can help to reduce fuel consumption by an additional 25%. The modular structure ensures significant long-term economic advantages over rigidly designed driveline configurations.

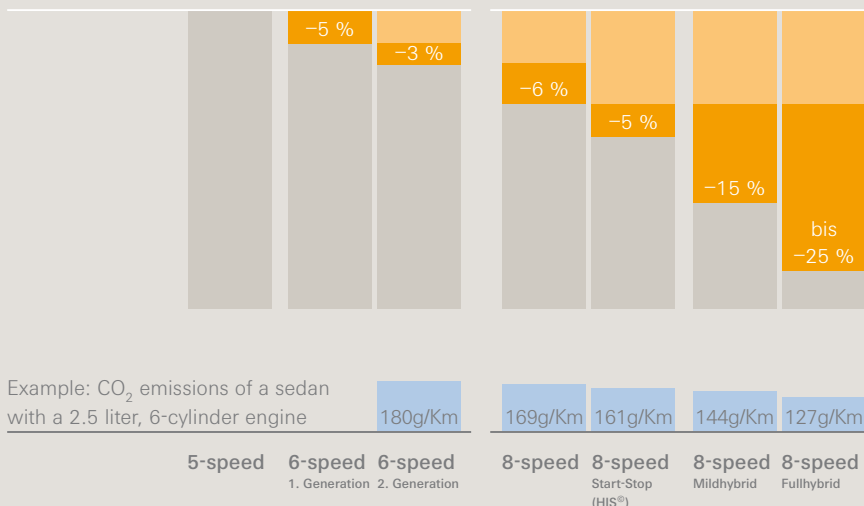

ZF Automatic
Transmissions –
Fuel Savings

Innovations that deliver for partners and drivers

With its transmission innovations, ZF seeks to achieve many goals: to satisfy reliable partnerships, create sustainable solutions for the future, and – last but not least – excite drivers worldwide. The 8HP shifts faster and more precisely than a professional driver, requiring less than 100 milliseconds to initiate a downshift when increased acceleration is desired. Whether comforta-

Since 2006 ZF has consistently won the readers' choice of the German magazine „auto motor und sport“ for the transmission category.

ble or sporty – every wish for individualized driving pleasure can be satisfied. Those who appreciate agility will be happy to know that the most modern adaptive shift strategies are used which enable direct skip-shifts over multiple gears, even allowing for extreme downshifts such as 8th gear to 2nd gear. In spite of the dry facts, maximum driving pleasure is guaranteed.

The automotive world has expressed its enthusiasm for the flexibility, variety of applications, and future potential of the 8-speed automatic transmission. The American trade magazine 'Automotive News' awarded ZF the 2010 PACE Award for the engineering of the 8HP.

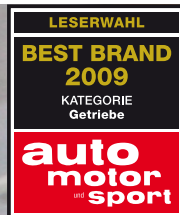

ZF Friedrichshafen AG
PO Box 650464
66143 Saarbrücken
Germany
Phone +49 681 920-0
Fax +49 681 920-2377
www.zf.com

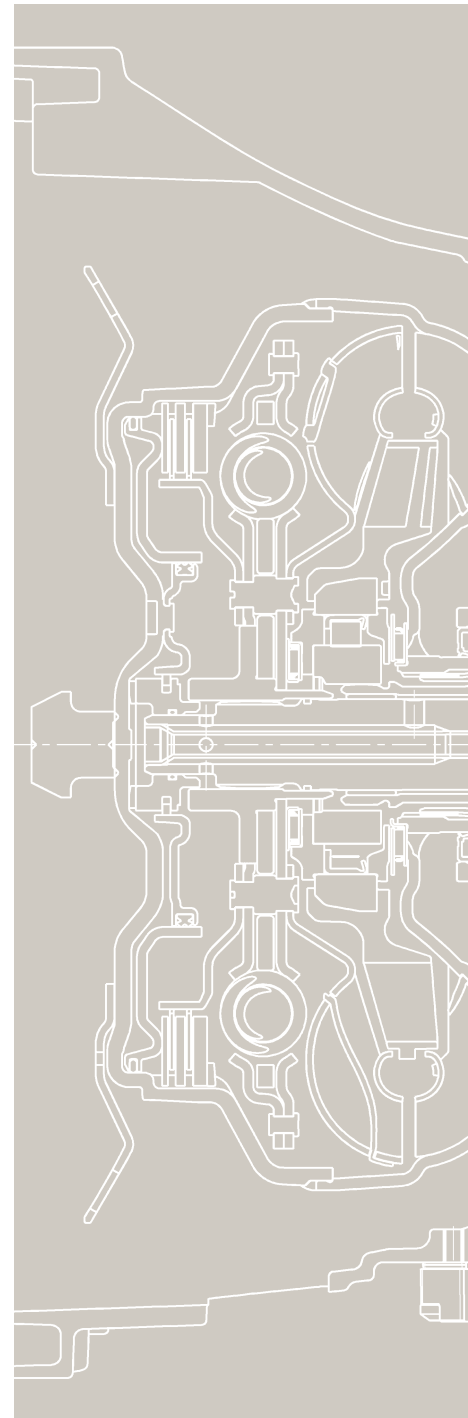

Driveline and Chassis Technology