

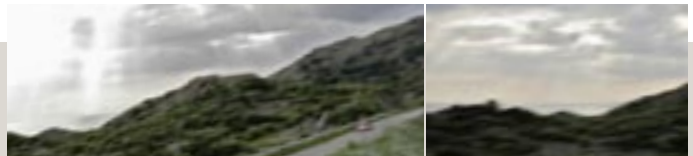

# The Freedom to Exceed Limits

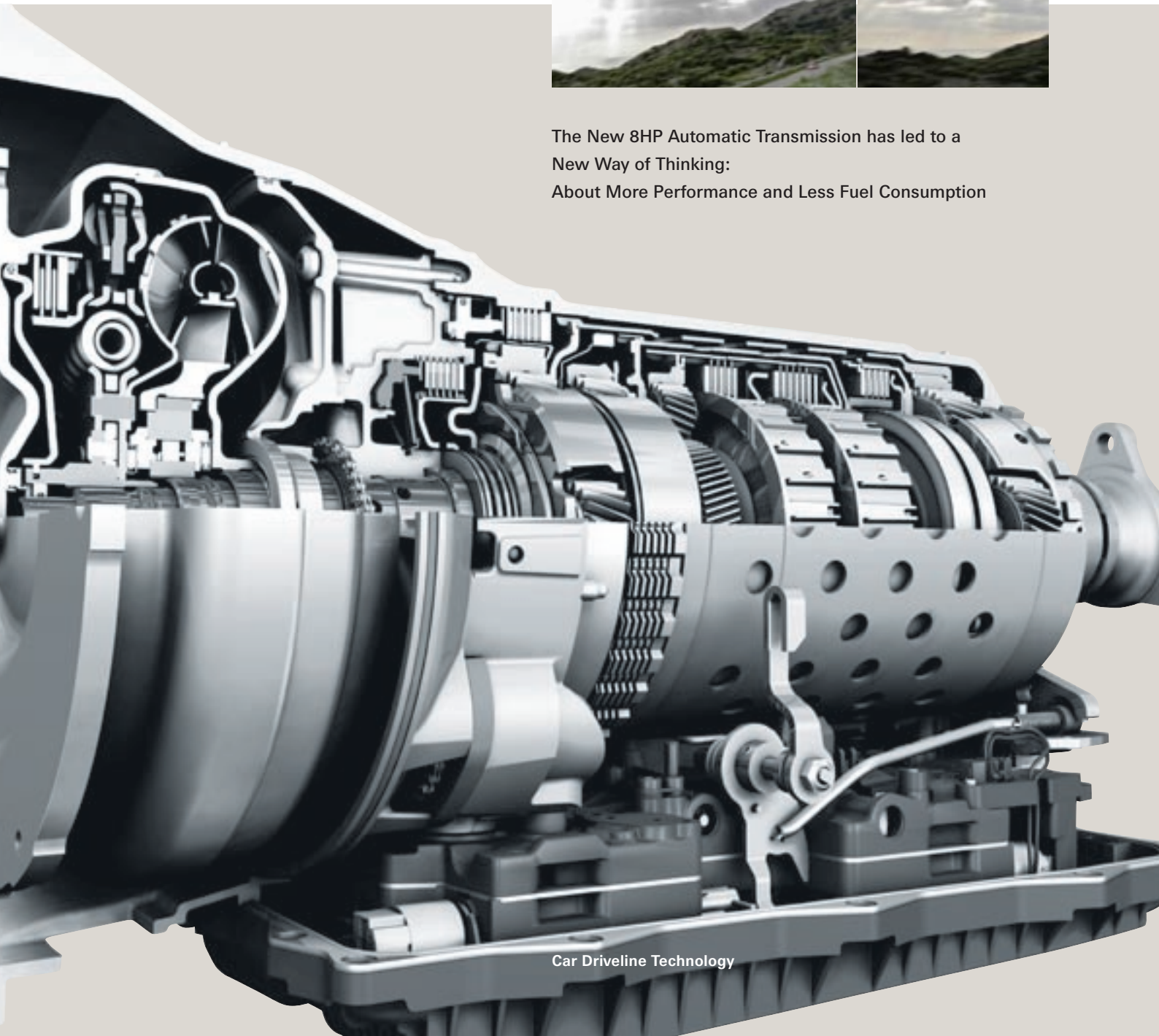

The New 8HP Automatic Transmission has led to a  
New Way of Thinking:  
About More Performance and Less Fuel Consumption





## Transmission System

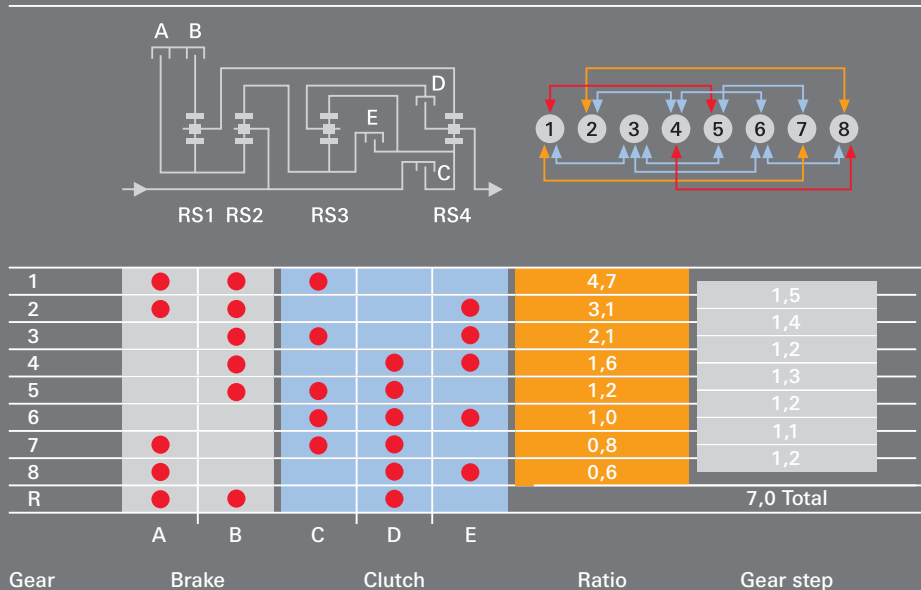

## The Art of Stripping Away the Superfluous – And Still Getting More.

At a first glance, the new added value formula seems to be a contradiction in itself. However, when taking a closer look, facts start speaking for themselves, and in favor of the new automatic 8-speed transmission by ZF.

### New gear set concept

The newly developed gear set concept by ZF is indeed revolutionary: With 4 gear sets, it operates with only 5 shift elements - and here, only 2 are opened per gear. This gear set concept with only 3 multidisk clutches and 2 brakes enables an extremely compact design at simultaneously improved efficiency.

### Higher overall spread

With an overall spread of 7.0, the transmission is always capable of providing the optimal engine range, in favor of better acceleration paralleled by reduced fuel consumption.

### Higher power-to-weight ratio

Here again, the automatic 8HP transmissions turns all standard perceptions upside down: It has two more speeds

at hand and transfers an impressively higher torque, while keeping the same installation dimensions. This is made possible thanks to the revolutionary gear set concept as well as the consistent application of newly developed, lightweight components.

### Less drag losses and more efficiency

As a result of the fact that only 2 shift elements are open per gear, drag losses in the transmission are sustainably reduced and, in parallel, the gear efficiency ratio is increased. Thanks to the development of a new axially parallel vane cell pump, transmission efficiency is increased even further. Energy losses are reduced to a minimum.

### ZF Automatic Transmissions - Weight Comparison

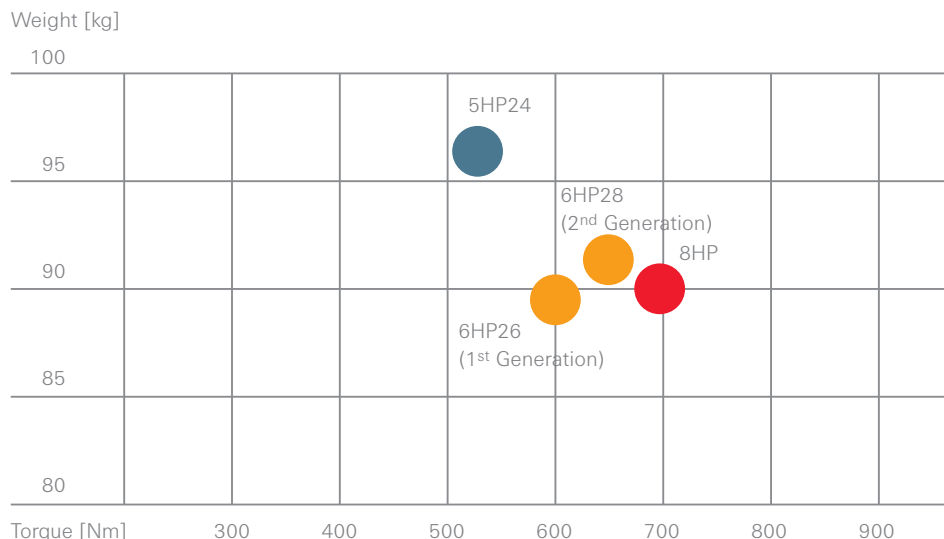



## Fuel Savings

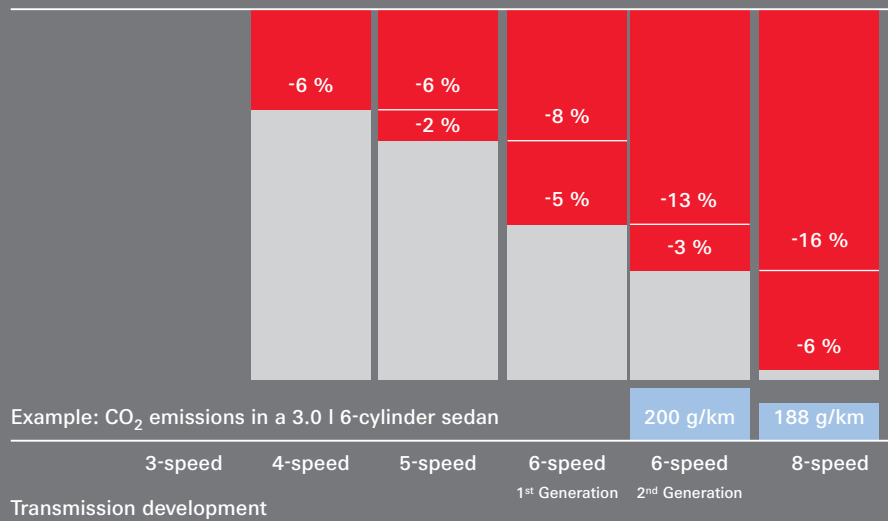

## Resources are Becoming More and More Expensive – As a Result, we Have Reduced Materials and Fuel Consumption.

The one who takes the freedom of ignoring old concepts is capable of defining new dimensions, instead of just living up to them. The new automatic 8-speed transmission by ZF sets new dimensions for all disciplines:

### Gear changes beyond the threshold of human perception

200 milliseconds suffice for the automatic 8HP transmission to initiate gear change. The shifting process is performed both spontaneously and comfortably. Not even a professional driver can shift that fast. This results in shifting characteristics, which combine driving pleasure and efficiency in a highly impressive manner. Moreover, direct shifts across several gears are enabled – up to extreme shifts, namely from the 8th down to the 2nd gear. Together with modern adaptive shift strategies, ultimate agility and maximum driving pleasure are warranted.

### 6 % less fuel

... in comparison to the present state of the art defined by the 2nd Generation

of ZF 6-speed automatic transmissions. The considerably lower power-to-weight ratio, the improved degree of efficiency, the higher transmission spread as well as the ultimate fine-tuning of some transmission components make a major contribution to it.

The stop-start function is offered as an additional feature with which the engine is automatically switched off when stationary and, with the release of the brake, engine and transmission are automatically re-activated.

### Significantly reduced CO<sub>2</sub> emissions

Once less fuel is consumed, a considerable reduction in CO<sub>2</sub> emissions is just the logical consequence. In a nutshell for the 3.0l 6-cylinder engine: This relates to another reduction of CO<sub>2</sub> emissions from 200 g/km to 188 g/km while benefiting in parallel from improved driving performance!

Basis Consumption of 2<sup>nd</sup> generation 6HP

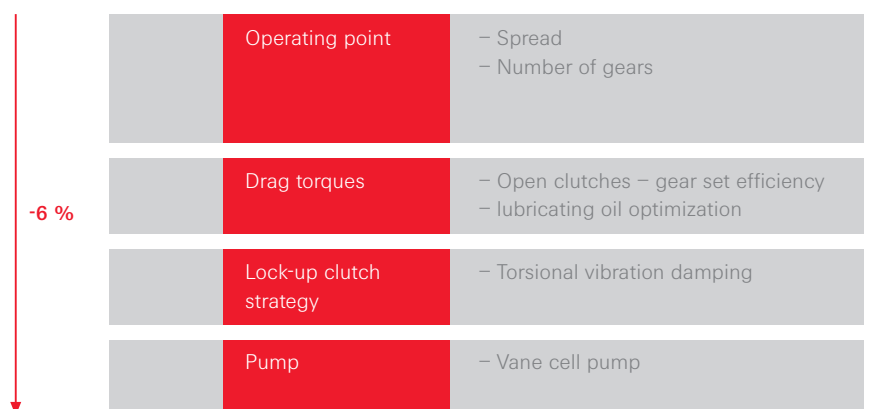

Target Consumption 8HP

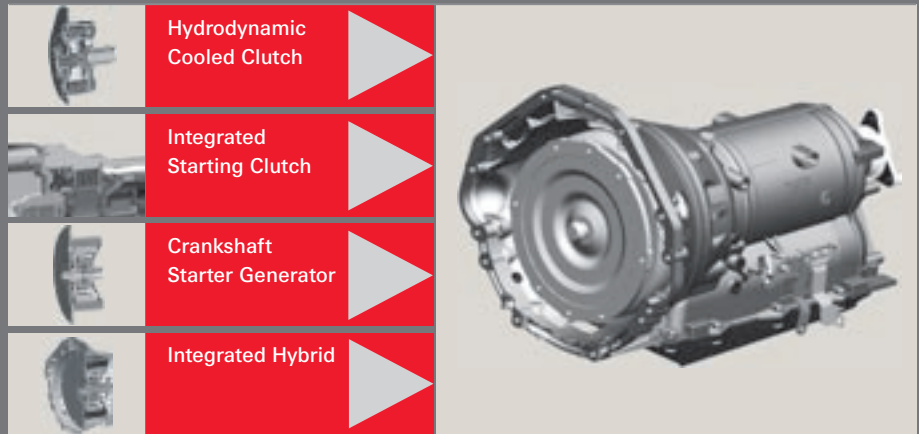

Basis: 3-line converter

Setting new dimensions is one thing –  
to still further improve these, that's ZF!

**The future already today.**

The automatic 8HP transmission was developed on the basis of a simple as well as highly innovative principle: A flexible modular set. Thus, already today, we have established the prerequisites for the use of current and future technologies which can be applied without having to alter the required installation space in the vehicle.

- Hydrodynamically Cooled Clutch
- Integrated starting clutch
- Crankshaft starter generator
- Integrated hybrid

The 8HP automatic transmission is also perfectly prepared for all different kinds of all-wheel drive concepts:

- All-wheel Torsen integrated
- All-wheel ToD (integrated)
- All-wheel Hang-On

**Enhanced driving dynamics for all driveline configurations**

For the automatic 8HP transmissions, the torque range encompasses a bandwidth of 300 up to 1,000 Nm. Within this performance range, the automatic 8HP transmission is the ideal partner for application in all vehicle concepts with rear and all-wheel drive concepts: from the lower middle class via sporty vehicles up to the luxury category and all-terrain vehicles

Kit for all-wheel drive technology



All-wheel Torsen, integrated



All-wheel ToD (integrated)



All-wheel hang-on

More gears – but not more weight.  
Enhanced acceleration but reduced fuel consumption.  
More torque but not more costs.



The time has come to re-think the overall picture!  
Welcome to the new automatic 8HP transmission by ZF.

Michael Paul, Technical Executive Vice President of ZF Friedrichshafen AG

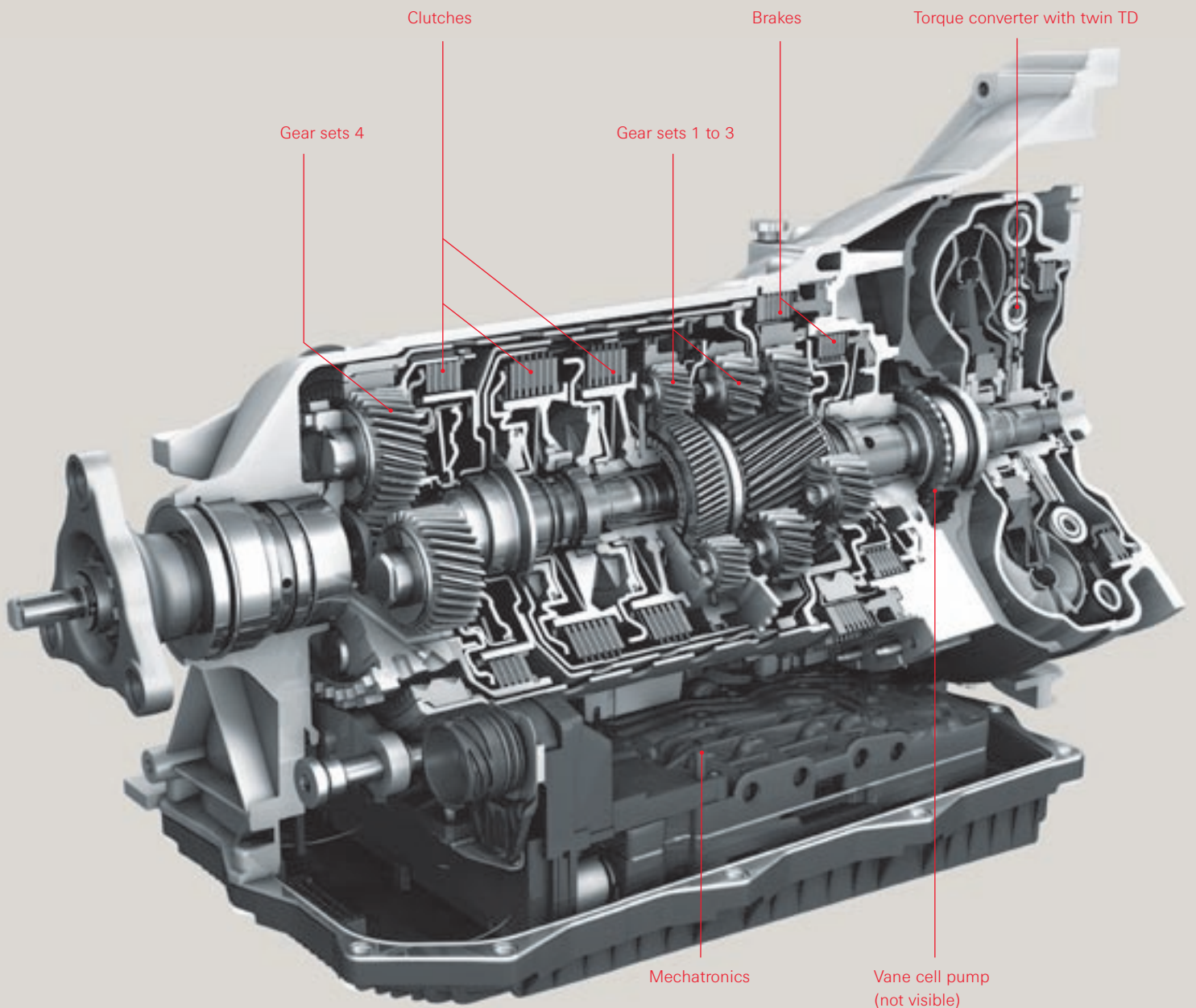

**ZF Getriebe GmbH**  
PO box 65 04 64  
66143 Saarbrücken  
Germany  
Phone +49 681 920-0  
Fax +49 681 920-2377  
pkw.marketing@zf.com  
www.zf.com



**Driveline and Chassis Technology**

