



ZF Friedrichshafen AG  
Special Driveline Technology  
Rail Vehicles  
D-88038 Friedrichshafen  
Germany  
Phone +49 7541 77-3246  
Fax +49 7541 77-90-3246

ZF Sachs AG  
Rail Vehicle Dampers  
Bogestraße 50  
D-53783 Eitorf  
Germany  
Phone +49 2243 12-383  
Fax +49 2243 12-280

e-mail: [rail@zf.com](mailto:rail@zf.com)  
[www.zf.com/rail](http://www.zf.com/rail)

Components and Systems  
for Rail Vehicles



Worldwide on Track



0010 762 160 Edit/bn/2008



Driveline and Chassis Technology

# Innovations of Great Value

"ZF develops and produces products serving the mobility of human beings and goods. Only innovations which make trains fast, safe, and comfortable motivate customers to travel in them. This is an obligation and a challenge at one and the same time."

Dr. Thomas Hegel,  
Director of the Special Driveline Technology  
business unit at ZF Friedrichshafen AG

Thomas Memmesheimer,  
Head of Sales and Development for  
Rail Vehicle Dampers at ZF Sachs AG

Hubert Groß,  
Vice President of the ZF Business Unit C.V.  
Chassis Modules (AL) at ZF Lemförder GmbH

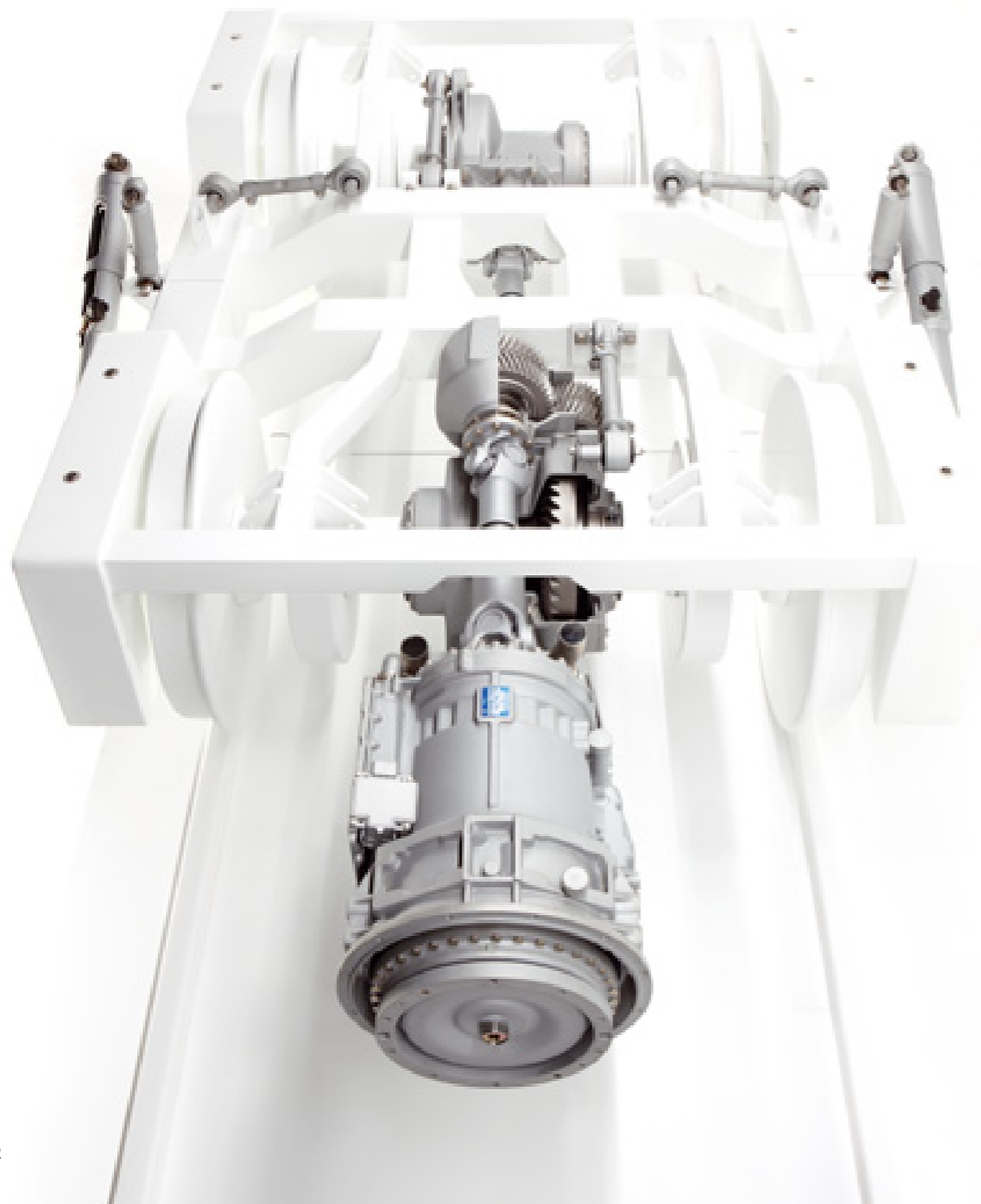

## Worldwide on Track

ZF is recognized as an excellent and reliable partner for innovative driveline and chassis technology. Optimum mobility for people and goods achieved through innovative products – ever since the early part of the 20th century, this core message has defined the thinking and action of this company. About 100 years later, the core brand was clearly defined. ZF leads in terms of technology, quality, and service. One reason for this: Every year, ZF invests approximately 5 percent of its sales in Research and Development.

Rail transport also benefits from this. Ever since its first "Rail Bus" project launched 55 years ago, the ZF Group's Special Driveline Technology business unit has been producing drive systems for the future of rail travel, capable of being integrated in existing systems. ZF Sachs AG, the Powertrain and Suspension Components division, creates rail vehicle dampers to meet all requirements. In the Commercial Vehicle Chassis Modules business unit of the ZF Group, every kind of connecting component for rail vehicles is manufactured.

By the cooperation of the three divisions, manufacturers and operators of rail vehicles are assured of flawless, reliable, and long-lasting products.

# The Driving Force – Powertrain Components and Systems from ZF

The things that manufacturers and operators of rail vehicles expect in the future have already been turned into practical reality in the form of ZF products: increased driving comfort and safety with reduced fuel consumption and lower emissions. Highly integrated products and superlative systems expertise are the key to this. All powertrain components are provided from a single source. The weight-optimized precision components are all perfectly matched within identical modules and can be combined to suit different performance classes.

Driveline systems from ZF are more than the sum of their parts. ZF's extensive in-house expertise translates straight into added value for the customer. It is this knowledge that extends the service life of ZF products and makes them more economical. A process aided by the intra-company transfer of technical know-how. For example, some aspects of transmission technology from the commercial vehicle sector can be utilized for rail travel. This cuts down development time.



**1 ZF-Ecomat Rail – Less Weight on All Rail Routes**

In its performance class, the ZF-Ecomat Rail is the smallest and lightest automatic transmission. The integrated retarder and torsion-damped torque converter make it suitable for use in rail vehicles. This applies to stop-and-go journeys and long-distance routes, and also to challenging route profiles. The retarder preserves the service brake and reduces maintenance costs. It also increases safety, causes less brake dust and thus protects the envi-

ronment. Additional safety is provided by the "Fail Safe Principle". In the event of a loss of system pressure, or failure of the power supply, the transmission automatically engages Neutral. Combined with a gear set reversing transmission, ZF-Ecomat Rail is suitable for diesel multiple units (DMUs) with input torques of up to 2000 newton meters and with up to six speeds. This compact modular design guarantees ease of installation. Engine-dependent PTOs can also be combined, e.g. for air-conditioning systems.

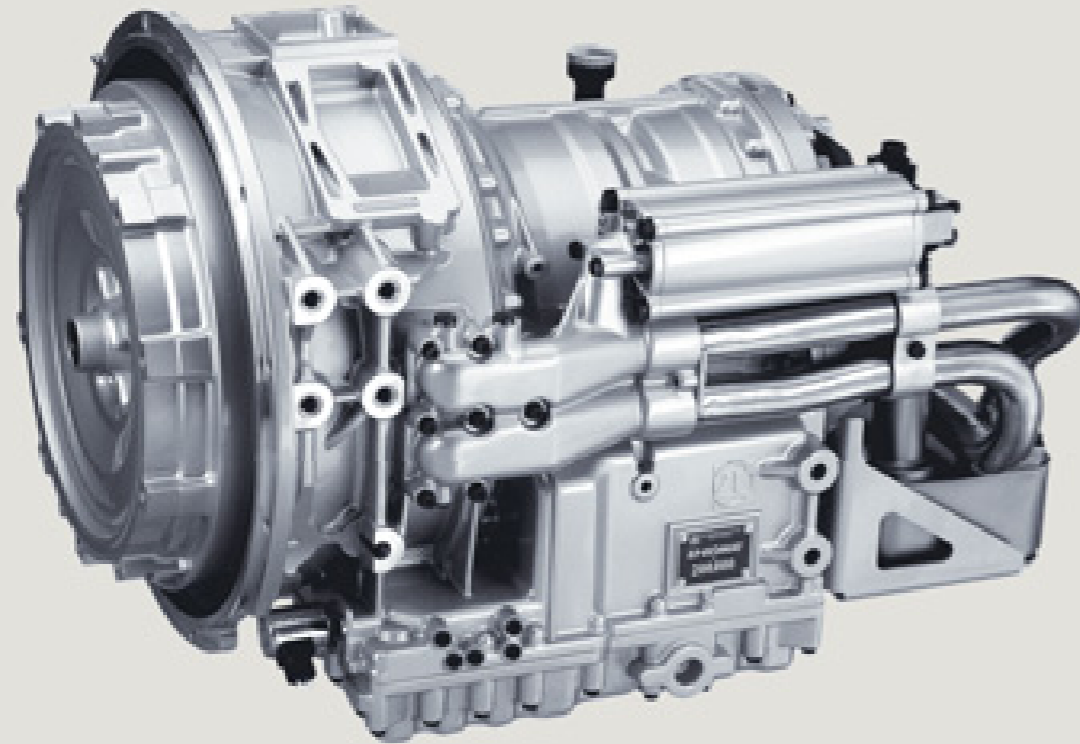

1

**2 ZF-AS Rail – Shifting Automatically, Driving Economically**

With this approach, the automatic ZF-AS Rail transmission stays on track and convinces with its highly developed shift strategy. It permanently keeps the engine in the optimal and most economical speed range and saves fuel. If required, the 12 gears can also be changed manually. Combined with a ZF gear set reversing transmission and the Rail Drive Control System (RDCS), ZF offers an ideally harmonized system. A light alloy housing encloses all transmission components, including the Sachs dry clutch in a compact shape.

The transmission does not need a lot of installation space and is quick to install. Its comparatively low weight of just 360 kg reduces axle loads. ZF offers three performance variants with input torque ratings of up to 3100 newton meters. Integrated assemblies guarantee high levels of reliability and protect all components as well as the electronic control unit from external factors. Numerous ratio variants and a high level of transmission efficiency reduce fuel consumption and emission levels. Depending on acceleration, weight and rail characteristics, the ingenious shift strategy automatically selects the most suitable gear.

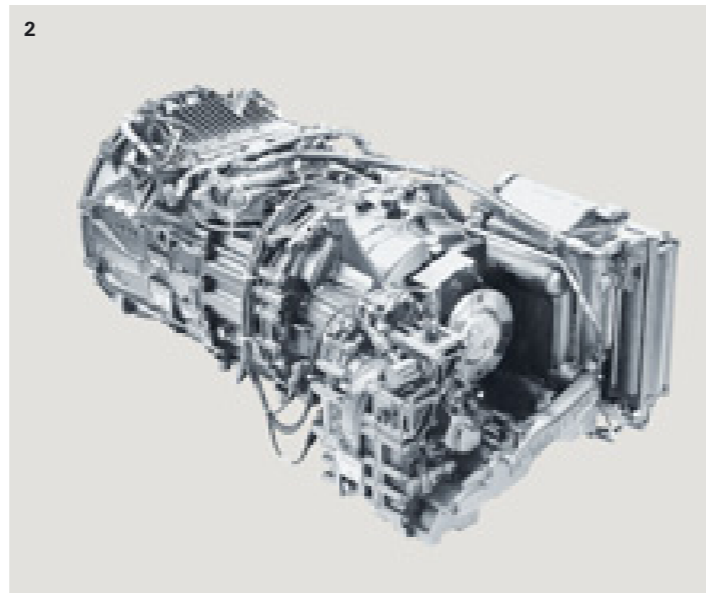

2

**3 ZF-EcoLife Rail – Powershift Transmissions for Every Application**

EcoLife Rail provides powershift transmissions with advanced characteristics. Its six speeds, combined with a gear set reversing transmission, are perfectly matched to DMUs with engine torque ratings of up to 2500 newton meters. EcoLife Rail trains protect the environment through their fuel efficiency and glides from one station to another, swiftly, quietly, and cleanly. Thanks to the optimized Sachs torque converter, the train accelerates in an exemplary fashion. The integrated retarder delivers excellent standards of retardation, providing higher levels of braking torque and more safety. At the same time, maintenance costs and environmental impact are reduced. In keeping with Ecomat Rail, the "Fail

Safe Principle" again delivers greater safety on the track. Even at high temperatures, ZF-EcoLife Rail runs reliably and delivers optimum availability. It does this with minimal fuel consumption and consistently high levels of shift comfort. Thanks to an improved cooling concept, oil sump temperatures of up to 120°C are possible. This is particularly important with regard to the modern Stage 3b standard diesel engines. The Rail Drive Control System (RDCS) controls the shift reversal process, coordinates the powertrain and is the central communication interface between train control unit and the ZF system (transmission, retarder & gear set reversing transmission). It also makes it easier to integrate transmission and axle reversing transmission. ZF-EcoLife Rail: A range to suit all applications.

3

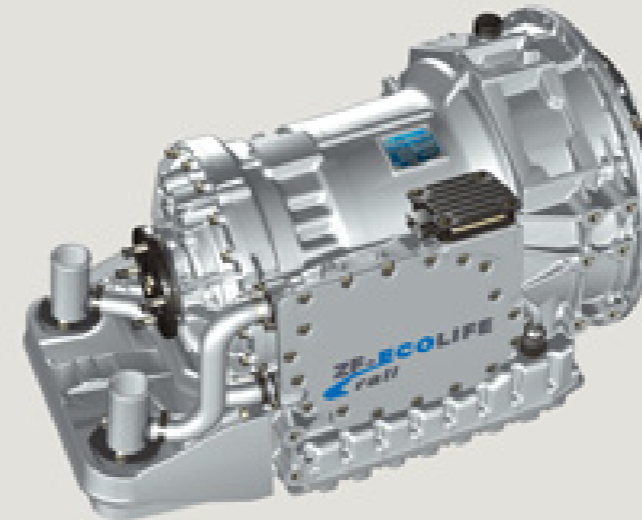

**4 Sachs Torque Converter – Saves Fuel**

With the new torque converter from ZF Sachs, the ZF-EcoLife Rail powershift transmission generates better acceleration values. A torsional damper is integrated in the torque converter and does not add to installation dimensions. It allows for fuel savings during the fuel-intensive starting processes by closing the lock-up clutch faster. Depending on the operation, fuel savings of approximately five percent are expected.

4

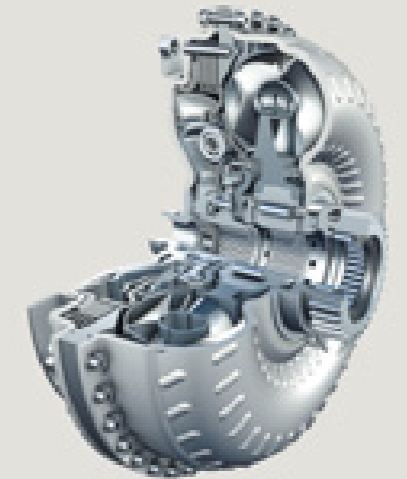

**5 ZF Gear Set Reversing Transmission – Power Right Down the Track**

Wheel set and gear set reversing transmission deliver engine power to the rail through the transmission ratio selected. These units drive the wheel sets and control their direction of travel. The wheel set and gear set reversing transmission – bevel gear and bevel helical gearbox – are based on a modular design. Axle load and ratio on these systems can be used in various ways. ZF offers gear set reversing transmissions for bogies with one or two driven axles. The Rail Drive Control System (RDCS) controls the entire shift reversal process in a fully automatic manner and reduces the cost of integration for the entire system.

5

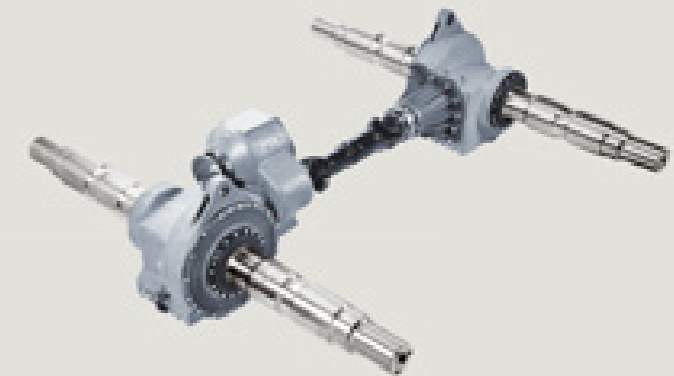

**6 Bevel and Spur Gear Transmissions – Individuality for Electric Multiple Units (EMUs)**

The experience gained also sets customers in good stead in terms of local transport. On the basis of existing transmissions, ZF develops individual solutions for EMUs (Electric Multiple Units). The advantages are obvious: ZF powertrain components are tailor-made, reliable, and substantially reduce the driving noise of light-duty rail vehicles. Optionally, ZF can offer 100% low-floor solutions. Passengers can get on and off without having

to cope with steps or different floor levels; center aisles are free of obstacles. This calls for immensely compact transmission concepts and for unconventional, vehicle-specific designs. Another plus factor: Plug-connecting axles for transport in confined spaces. With their compact dimensions, they offer integrated interfaces for the wheels. All transmissions can contend with axle loads of between eight and 21 tons with low levels of wheel wear. These units are lightweight and deliver many years of reliable service.

**8 ZF Axle Drives – More Power, Less Wear**

Technological innovation and modular design define the concept for ZF axle transmissions. Its standardized interfaces enable it to be used flexibly with customers. Switching and main line locomotives all operate more quietly. Proven ZF quality assures lower levels of wear, a consistently high power density, high standards of interface flexibility and, through this, great economy across the entire service life.

6

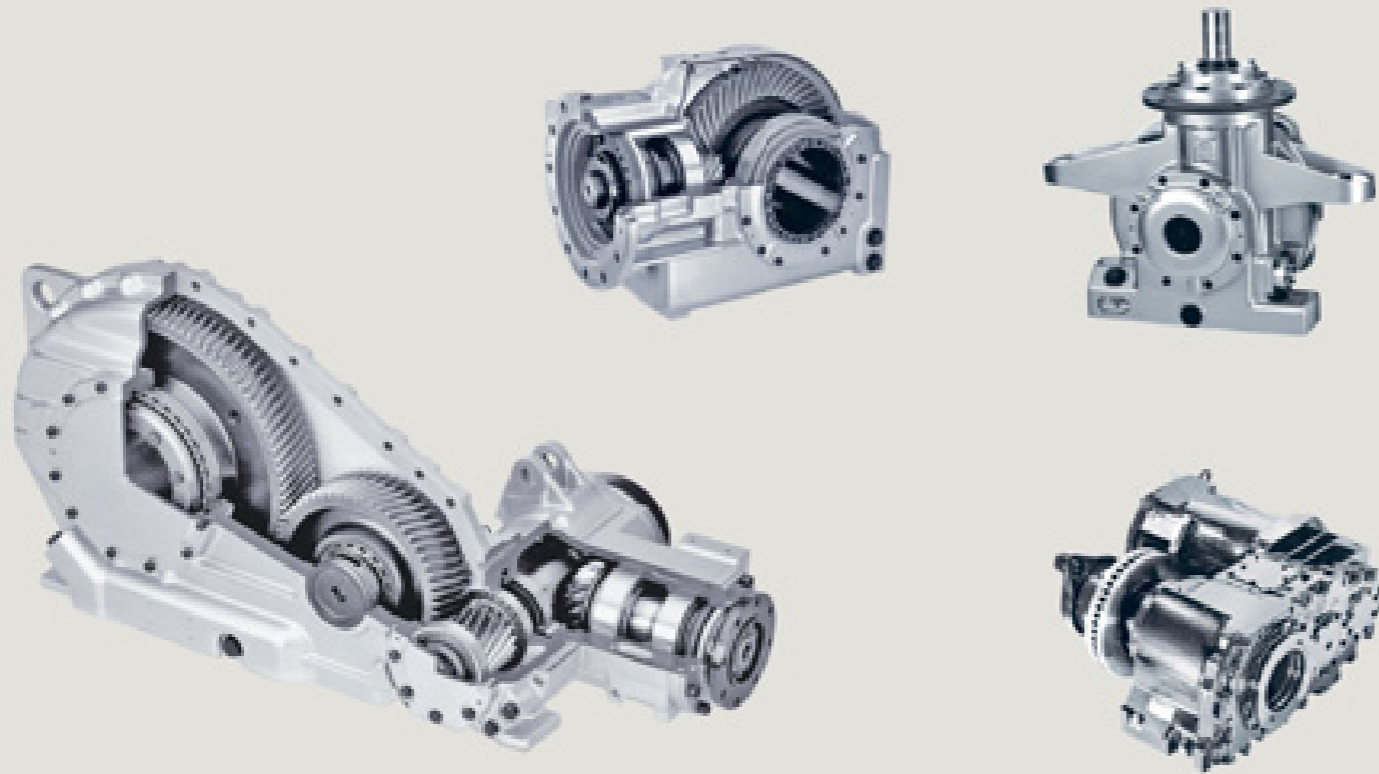

8

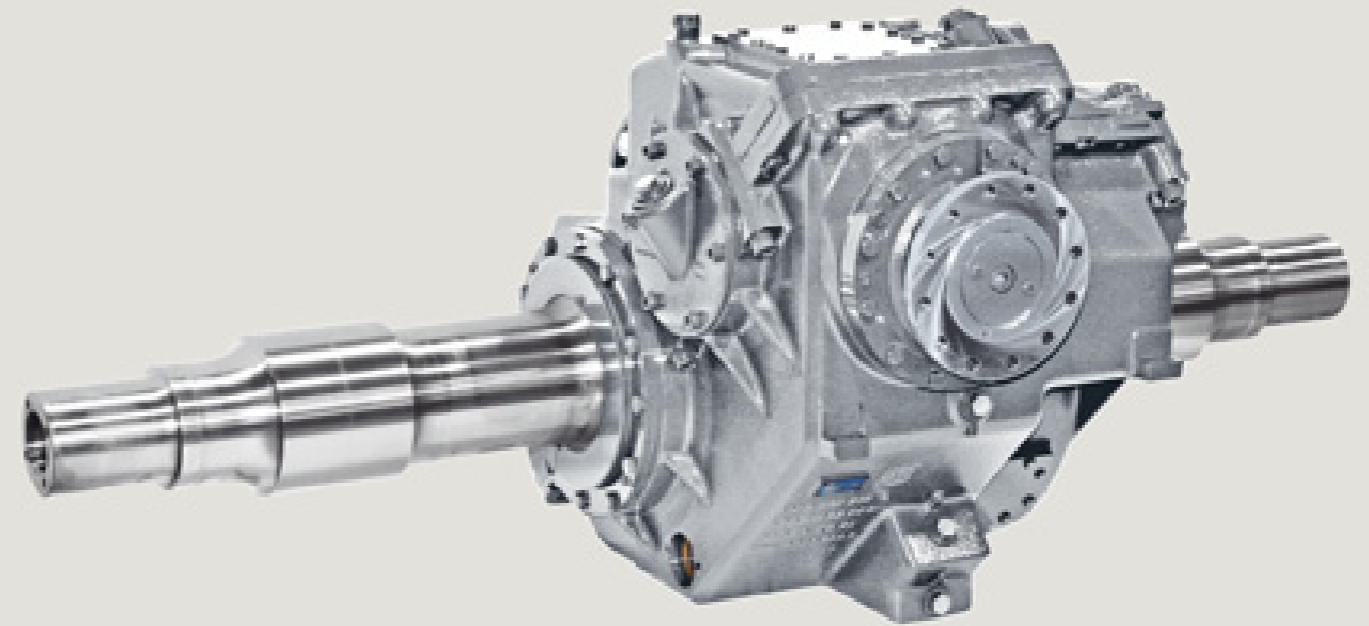

**7 Hybrid Technology – Economical and Environment-Friendly**

Hybrid technology combines the advantages of electric motors and diesel engines in a single unit. It combines low fuel consumption, fast acceleration, low noise levels, and exemplary emission values in a superlative drive system. In the parallel hybrid system, gasoline engine and electric motor drive the wheels separately or in combination. The main components

are the electric motor and combustion engine, a battery, inverter, and a transmission. An intelligent control unit ensures that the advantages of both propulsion concepts are utilized to the full. The hybrid also stands out when it comes to economy, in that it offers greater comfort while braking, as well as better acceleration. Its capabilities are convincing in both operating modes. You can choose to set off fast, or slowly in "Eco" mode.

7

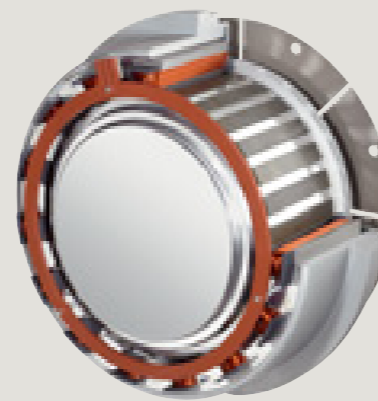

**9 ZF-Ergopower – Quiet Operation for Long Service Life**

ZF transmissions for track-laying vehicles set new standards on the market. Quiet operation and low peak loadings extend their service life and improve their reliability. They create greater comfort on board and inside the vehicle, and enable it to operate more economically. Their high helical gears minimize noise levels. Vertically positioned, the spur gear ratios bridge the height difference between input and output shafts. For this reason, the housing integrates the axle differential, dispensing with the need for an additional transfer case. ZF-Ergopower transmissions are able to change direction of travel without an additional reversing stage.

9

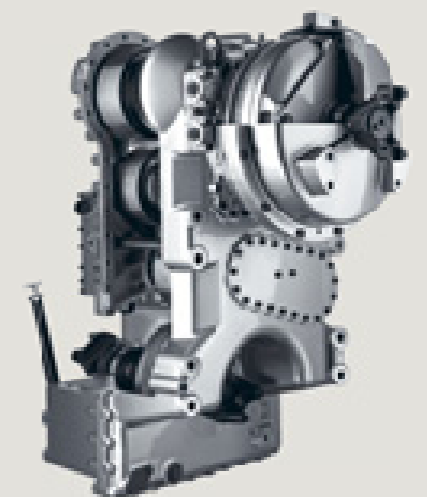

# Innovations That Move People – Suspension Components and Systems from ZF

Modern chassis technology for rail vehicles should be quiet, comfortable, reliable and environment-friendly. No easy undertaking when you consider the inherent technical challenges. Here's an example: In passenger transport, trains are now very much holding their own against airlines. However, once traveling at more than 250 kilometers an hour (>150 mph), wear and maintenance costs of rolling stock and the rail system rise almost exponentially. As a technology leader, ZF is also setting new standards here, and offers perfectly matched damping components and system for all types of rail vehicle.

Globally networked processes with customers and suppliers form the basis for developing these high-tech products. Dynamic simulation, high-precision test procedures and virtual product development lead to ingeniously mature technical solutions built from high-quality and robust materials. Highly-skilled teams, flexible structures, and the latest production technology guarantee maximum service life, the key to conserving resources. All products and production processes are designed to have the lowest possible levels of environmental impact. Passengers and goods on the railways are also entitled to reach their destinations safely, quickly, reliably, and cost-effectively. ZF suspension components and systems lay the best possible groundwork for achieving this goal.



**1 Sachs Yaw Dampers – Improved Safety at High Speeds**

ZF Sachs yaw dampers increase the veering-out resistance and minimize sine wave effects. The critical speed of the bogie is increased by this. Optimum technology from ZF Sachs combines three ingenious functional principles: The twin-tube and hydrodynamic process, and the damper version with full-length piston rod. These deliver service lives well above the average. The damping forces in

tension and compression directions are identical. The dampers possess block safety and great dynamic stiffness. A space-saving design and a standardized modular structure make this unit economical to manufacture. By virtue of this special design, venting prior to the installation is not required. In addition, electrically switched valves can be installed. Sachs yaw dampers are economical because they are easy to recondition.

**2 Sachs Vertical Dampers – Cost-Effective and Efficient**

Vertically installed Sachs twin-tube dampers offer a range of advantages and are available in a choice of two sizes, to suit different load patterns. As you would expect from a Sachs product, these units deliver exceptional lengths of service life. Piston and floor valve settings can be adjusted, thereby achieving a high level of variance in terms of their characteristics curves. Their standardized and modular design is an essential requirement for cost-effective manufacture of these dampers. By virtue of this special design, the system is easy to recondition. As an option, an integrated lift stop is offered. This device holds the axle on the bogie and the bogie on the rail whenever these vehicles are being put onto the rails.

**3 Sachs Horizontal Dampers – Operate in Every Position**

ZF Sachs twin-tube dampers for horizontal installation are designed in a similar way to vertical dampers and offer the same advantages. A special feature is the design of the floor valve. This special design ensures that, particularly when dampers are in a horizontal position, no air is able to enter their working chamber. This ensures that each damper can function reliably, even when installed in a horizontal position.



#### 4 Sachs Carriage Body Dampers – for More Anti-Roll Stability in Trains

Carriage body dampers are special variants of the ZF Sachs horizontal damper. These are used between two neighboring carriage bodies. Their function is to inhibit lateral vibrations between the carriage bodies, e.g. pitching, yaw and out-of-phase rolling on long straights and when negotiating gentle curves.



#### 5 Electrically Controlled Yaw Dampers – Reduce Costs

Wheel sets and tracks wear when cornering as a result of the higher levels of wheel-to-rail forces. Electrically switchable yaw dampers, a recent ZF Sachs innovation, reduce these factors and also substantially cut down on maintenance costs. The principle: A bypass, controlled by a two-way valve, switches off the damping function when required. Vehicle acceptance tests are subject to maximum permitted wheel-to-rail forces. In some cases, these requirements can only be satisfied through the use of this technology.

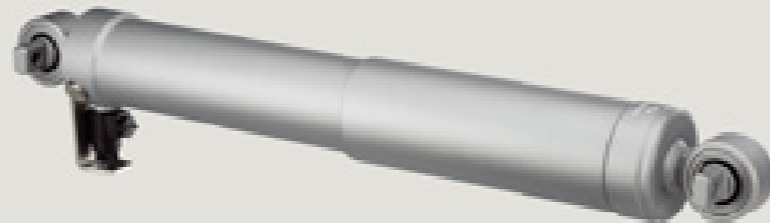

#### 6 Torque Reaction Links – Active Roll Stabilization (ARS) and Torque Roll Restrictors

The torque reaction link is used as a flexible connection in anti-roll support applications. It transmits forces from bogie to carriage body. With our modular system, these links can be adapted to create perfect matches with customer requirements. Alternatively, vibration-absorbing rubber-metal mount-

ings or zero-backlash sliding-contact bearings can be used to provide these flexible connections. The torque reaction links can be manufactured with longitudinal adjustment, or as fixed-length units. In addition, they can be used as transmission supports in the drive bogie. In this function, referred to as torque support, these units again provide a vibration-damping mounting.



#### 7 Adjustable Wishbones – Flexible Connection for Carriage Bodies

Adjustable wishbones from the CV Suspension Module business unit of the ZF Group create flexible connections on carriage bodies beside the gaiter or bellows. With variable length and adjustable spread angle, these units are ideally suited for flexible use in various connection systems. Versatile links transmit longitudinal and lateral forces. Among other things, they reduce noise levels and improve ride comfort. Their design is based on prevailing customer specifications.



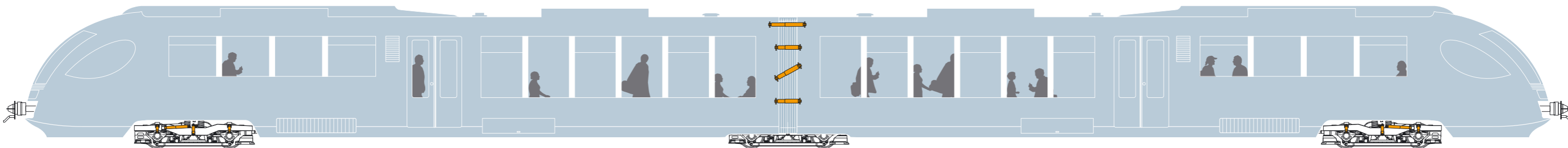

## Combining Benefits. In the System of the Future.

ZF engineers set out to meet current challenges and to develop pioneering technologies for rail vehicles. This approach results in low vehicle weight, greater ride comfort and safety as well as reduced fuel consumption and lower emission levels.

Highly integrated products are the key to this. The components are matched in identical modules and weight reductions are achieved. Available from a single source, and functioning as a complete system, they deliver greater safety and economy. ZF technology for rail vehicles combines the very latest of components and a high level of systems expertise:

- With the 6-speed EcoLife transmission and a gear set reversing transmission, diesel multiple units glide down the tracks with engine torque ratings of up to 2500 newton meters, traveling from one station to the next quickly, quietly and cleanly.
- The Rail Drive Control System (RDCS) is a central communication interface between the train control unit and the ZF system. RDCS controls the entire reversing shift process. It constitutes the control unit between transmission and axle reversing gearbox. RDCS reduces the cost of integration, and the customer benefits from systems expertise.
- Damping technology is based on the use of standardized twin-tube dampers. By virtue of their modular layout and space-saving design, these dampers can be installed in vertical or horizontal positions. For more complex requirements on bogie and carriage body, ZF Sachs offers yaw dampers and "Inter-Car" dampers. The electrically controlled yaw damper rounds off the product range.

The ZF product portfolio for rail vehicles at a glance:

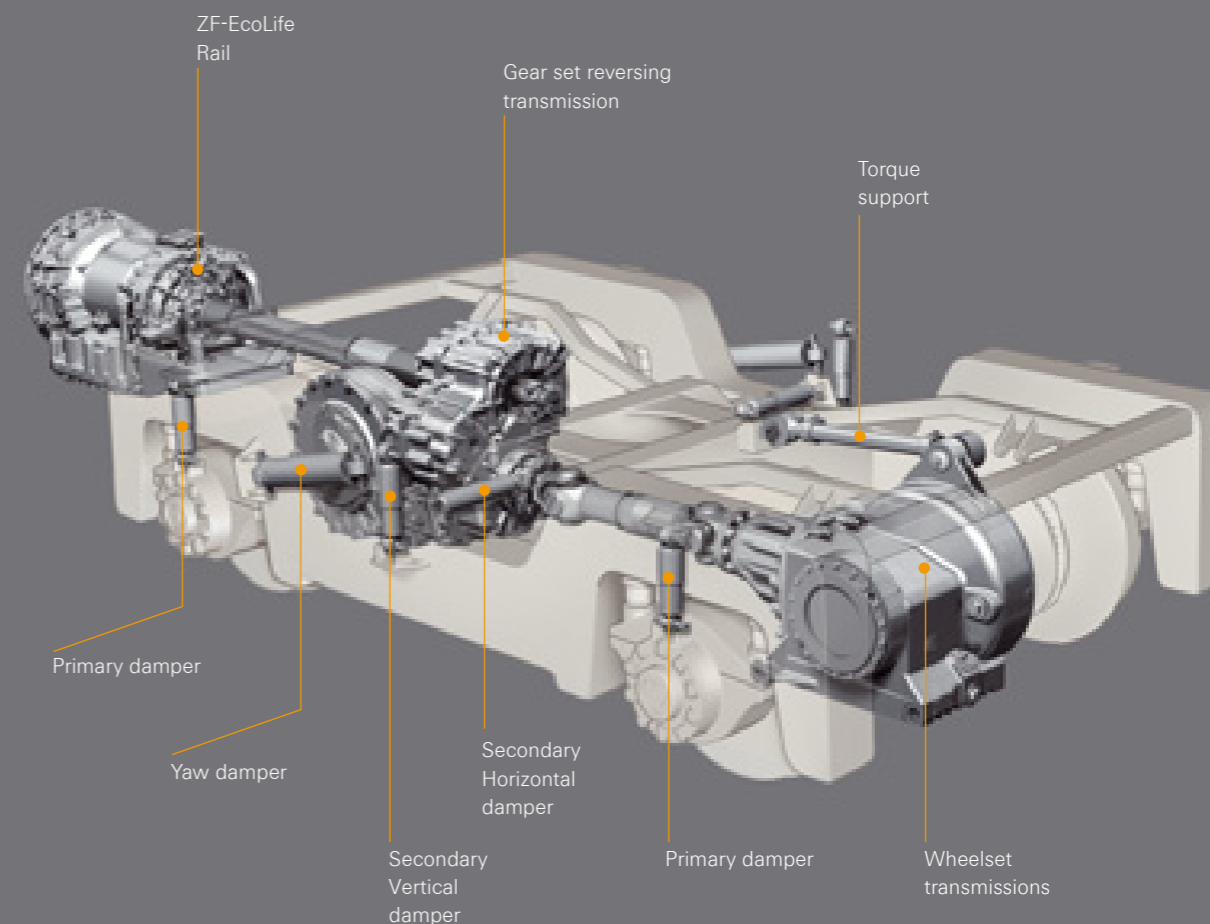

### Modular kit system

Individually combined modular components of all performance classes optimize the driveline. Ride comfort is increased and fuel consumption reduced.

### Safety

The retarder protects the brake system without limiting safety. In the event of a loss of system pressure or failure of the power supply, the transmission automatically switches into neutral thanks to the "Fail Safe Principle".

### Profitability

Low life cycle costs through integrated retarder: it preserves the service brake and reduces maintenance costs.

### Electromagnetically compatible

Devices and systems of the vehicle, on the inside and the outside, work without problems – meeting the requirements of the European EMC Directive.

### Systems integration

Swift availability reduces downtimes; few interfaces increase reliability; ZF offers end-to-end responsibility.

### Simplified assembly

A compact structure creates more freedom in design and facilitates assembly. No engine removal required.

# Economical Driving. Tailor-Made Solutions.

An average of 30 years of operation in passenger and goods transport means one thing: The cost-effectiveness of a train depends to a large extent on the service life of its components. Faster journey and transport speeds, driving safety, and more demanding requirements on comfort require continuous improvements in components. Cheap can rapidly turn expensive. To maintain their competitiveness, ZF customers place their confidence in quality and tangible customer benefits. Intense customer-specific research and

development work coupled with cutting edge production technologies are the key to achieving this. Longer service lives, higher mileages and less wear on components and systems are the outcome. Something which pays off for manufacturer and operator alike.

The capabilities expected of rail vehicles are rising all the time: Increased fuel efficiency and reduced noise emissions coupled with better environmental credentials are called for. In these areas, ZF is setting new standards. For example, in 2008, ZF became the first European company to start volume production of hybrid drives. Rail transport also benefits from this. With the hybrid version of EcoLife Rail, an ultra-modern transmission will be available in future which offers all the benefits of hybrid technology. The intelligent interaction between electrical and engine-powered driving modes conserves resources, thereby substantially reducing CO<sub>2</sub> emissions. This also makes sound environmental sense.

# ZF. As Good as the People Behind it.

A leader in technology, quality, and service, while still remaining competitive. This is not a contradiction but also not implicit. Every single day, the employees at ZF face up to this challenge in order to meet these high standards.

The high skills level attained by its employees is therefore a core success factor for ZF. Employees have a key role to play in the success of the company by identifying future requirements at an early stage and by devising appropriate solutions for its customers. They are the backbone of ZF's ability to innovate and to compete.

The high quality of ZF products and the unique development capabilities of the Group are the result of targeted personnel development and further qualification. Management, teamwork, experience, specialist knowledge, and personal responsibility are all directed consistently towards the goals of added value and customer benefits.

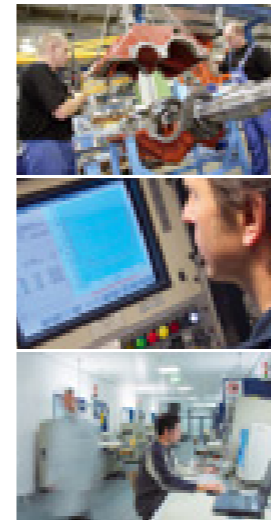

# Short Routes and Fast Service. Worldwide.

Nowadays, customers expect additional services going beyond standard servicing, to keep their vehicle powerful throughout its life cycle. Seven days a week, round the clock, ZF has its own sales and service companies where staff are always available as local customer contacts and problem solvers. With over 700 authorized ZF After-Sales Service Centers and ZF Sachs partners, the company can offer flexible and timely intensive support backed up by fast delivery of spare parts.

**Short routes and fast service**  
There are more than 700 ZF After-Sales Service Points with the complete service spectrum worldwide.

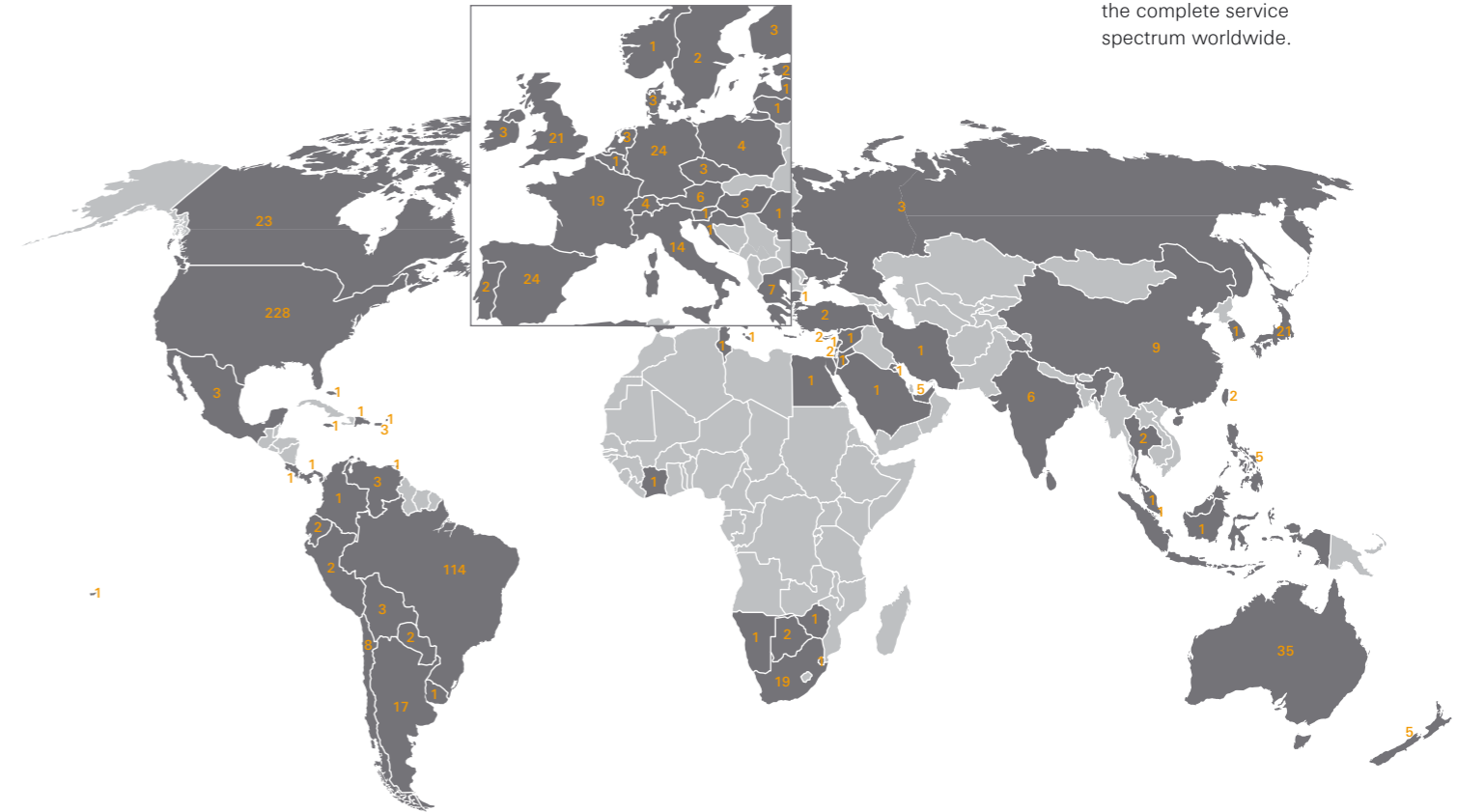

**A few services that contribute to this:**

- Conversion and retrofitting of individual modules
- Major overhaul for complete drive systems
- Dynamic damping force measurements during train operation
- Maintenance-free rail vehicle dampers
- Easy reworking of rail vehicle dampers
- Investigations to optimize maintenance intervals
- On-site product training
- Provision of test equipment
- Exclusive use of genuine parts
- Worldwide ZF warranty
- Over 55 years of experience in rail transport



# The Basis of our Success.

ZF is a leading worldwide automotive supplier for Driveline and Chassis Technology.

With total sales of euro 12.6 billion in 2007 and 57,500 employees in 119 production companies in 25 countries, ZF is one of the world's 15 largest automotive suppliers.

ZF develops and produces products serving the mobility of human beings and goods. Innovations in Driveline and Chassis Technology provide increased driving dynamics, safety, comfort, and economy as well as lower fuel consumption and emissions in the vehicles of the customers: by land, by sea, and in the air.

ZF's main priority is to meet its customers' needs by using leading technology, quality, and service; this is the key to strengthening the international market position. In addition to the benefits of component expertise, the customer profits from the Group's system know-how.

The ZF Group is a decentralized company. Its divisions and business units operate independently and flexibly on the market; they are managed strategically and financially by the Group.

ZF plays an active role in society and is continuously engaged in a dialog with the public and with its employees. The company promotes employees based on qualification, performance, work ethics, and mobility. The company assumes social and societal responsibility. Environmental protection is a professed corporate objective.



## Driveline and Chassis Technology



**Car Driveline Technology**  
ZF Getriebe GmbH

**Commercial Vehicle and Special Driveline Technology**  
ZF Friedrichshafen AG

**Off-Road Driveline Technology and Axle Systems**  
ZF Passau GmbH

**Marine Propulsion Systems**  
ZF Padova S.p.A.

**Aviation Technology**  
ZF Luftfahrttechnik GmbH

**Services**  
ZF Friedrichshafen AG



**Car Chassis Technology**  
ZF Lemförder GmbH

**Rubber-Metal Technology**  
ZF Boge Elastmetall GmbH



**Powertrain and Suspension Components**  
ZF Sachs AG



**Steering Technology**  
ZF Lenksysteme GmbH\*

\* A joint venture of ZF Friedrichshafen AG and Robert Bosch GmbH