



# ZF POD

Pod Drive System

4000 Series

when tradition merges with revolution



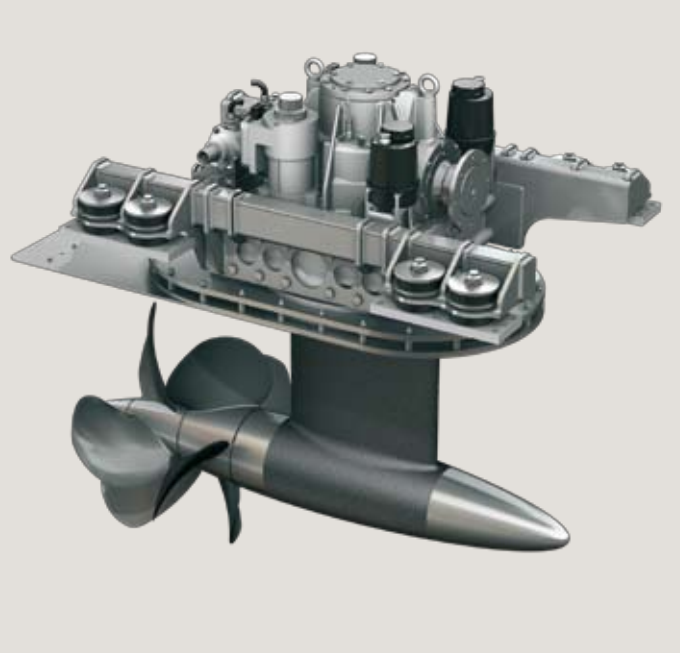

## Efficiency

The ZF POD is one of the most efficient propulsion systems, ideal for large, twin-engined pleasure craft of 50 to 75 feet overall length, but equally suitable for superyachts up to 120 feet, with a triple or quad configuration.

The increased propulsion efficiency, compared to traditional shaft-line systems, can result in speed increases up to 15% and significant reduction in fuel consumptions at cruising speed (up to 20%). Better performance also means less environmental pollution and reduced initial and through-life costs.

The system comprises a conventional transmission and steering pod system equipped with counter-rotating propellers, managed by an electronic control system.



speed and turning circle, which results in excellent handling and superb response. The reliable, smooth, electric motor which steers each pod is fitted with sensors which optimize boat handling under all conditions.

The vertical installation of the pod units gives the boat exceptional stability when turning at any speed.

## Maneuverability

The ZF POD is controlled by ZF's SmartCommand control system and the JMS (Joystick Maneuvering System), which ensures safe cruising and easy maneuvering.

Each pod is rotated independently, depending on

Using trolling valves and the advanced Joystick Maneuvering System (JMS) all ZF POD maneuvering functions are precisely controlled and simply intuitive. One hand controls it all - sideways tracking, turning on the spot – all with accurate speed control. Whether at the dock or backing down on a blue marlin, this total command and maneuverability is unbeatable!

The optional “iAnchor” function, thanks to an integrated GPS receiver, enables the vessel to be kept at an exact position and orientation at the press of a button.

## Ratings

A full range of propeller sizes and pitch angles is available, making this system perfectly suitable either for planing or semi-displacement boats,

driven by any diesel engine within the approved power range up to 3670 Nm (2716 lbft) in pleasure duty (i.e. 1200 hp at 2300 rpm).

Model	Ratios	Power/rpm		Input Power Capacity						Max Input Engine rpm	Weight	
		kW/rpm	hp/rpm	2100 rpm		2300 rpm		2450 rpm			kg	lb
				kW	hp	kW	hp	kW	hp			
ZF POD 4000	1,985	0,385	0,516	809	1083	886	1187	943	1264	2500	~1000	~2200
	2,212	0,368	0,493	772	1035	846	1134	901	1207			

## Safety

If the pod drive strikes underwater debris, the aft-facing propellers are protected by the pod gear casing.

In the event of hitting a substantial object, the gear casing is designed to shear below the hull, minimizing damage to the drive and minimizing repair costs!

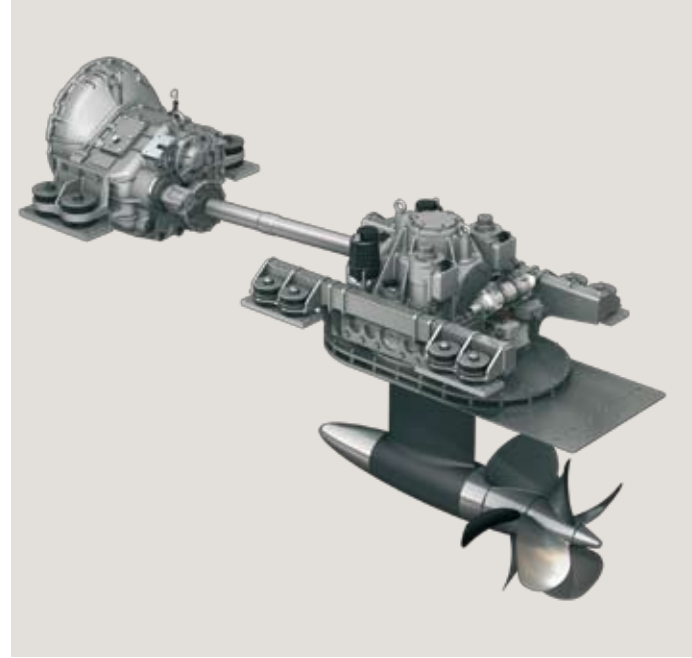

## Comfort and Installation Simplicity

The ZF POD uses counter-rotating propellers and is mounted on large rubber supports. Gear noise and vibration are therefore significantly reduced, resulting in a quiet, comfortable ride.

Since the thrust is transferred to the stringers and not through the hull, the traditional fiberglass lamination process doesn't have to be changed. Naturally, the drive can also be installed in aluminum hulls.

The compactness of the ZF POD maximizes accommodation space and fits all boats, including low-deck sport fishing.

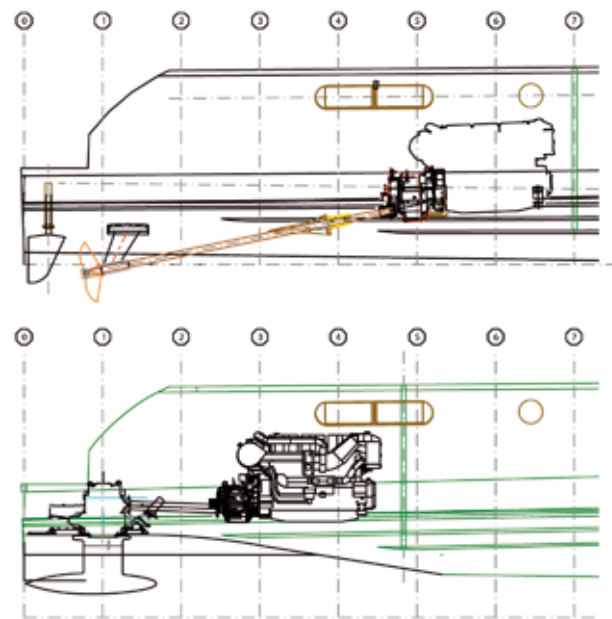

## Selected features

- Drive-by-wire, electrically actuated steering
- Joystick with proportional speed control
- Electronic throttle & shift control
- Electronically controlled interceptors
- Auto sync
- Single lever control
- Docking mode
- Trolling mode
- Warm-up mode
- Display
- iAnchor

The 4000 series POD has been developed in

cooperation with  and 



**ZF Padova s.r.l.**  
Via Penghe, 48  
I - 35030 Caselle di Selvazzano (PD)  
ITALY  
Phone +39 049 8299 311  
Fax +39 049 8299 550  
[www.zf.com](http://www.zf.com)



**Driveline and Chassis Technology**



Photo: courtesy of Azimut

03 75 006 0710 - July 2010