



# Sail Drive System





# Sail Drive

ZF Marine has now added Sail Drives, (ZF SD) to their already comprehensive range of marine products.

ZF Marine has long-standing experience with this well-known propulsion system for sailboats, and is now making it available to all engine manufacturers.

ZF SD offers the well-recognized advantages of excellent hydrodynamic efficiency and ease of installation.

The system offers boatbuilders increased design flexibility, allowing the engine to be positioned facing forward (facing the bow) or backward (facing the stern) with respect to the transmission. ZF SD considerably reduces vibration and other related propulsion system noise on board, compared to a traditional shaft line system.

The most important feature is the ease and the safety of installation, as no particular settings or alignments are necessary.



The system is robust and reliable, and can be matched with a large range of fixed or foldable propellers, moving the vessel powerfully both in forward and reverse.

The exceptional efficiency of the Sail Drive is obtained both through reducing the hydrodynamic resistance of the immersed section of the drive, and maximizing thrust efficiency, through a design that positions the propeller exactly parallel to the moving direction of the hull of the vessel.

Two different models of the Sail Drive are available: the ZF SD 10 rated to 150 Nm (75 hp @3600 rpm) and the ZF SD 12 rated to 180 Nm (92 hp @3600 rpm).

## ZF Sail Drive Range

### Technical data

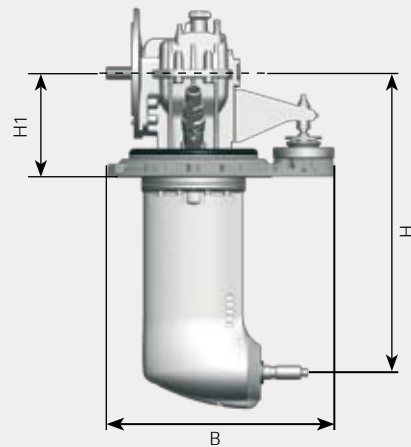
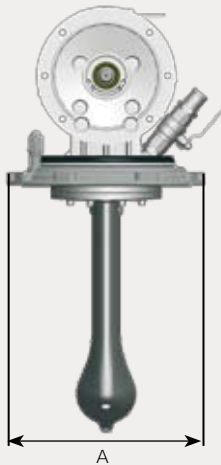

Model	Ratios	Power/rpm		Input Power Capacity				MAX RPM	Weight		Clamp ring flange dia.- A		Clamp ring flange dia.- B		Drop - H		Height - H1	
		kW/rpm	hp/rpm	3200 rpm		3600 rpm			kg	lb	mm	inch	mm	inch	mm	inch	mm	inch
				kW	hp	kW	hp											
SD 10	2,23:1	0,0153	0,0208	50	67	55	75	3800	40	88	378	15	463	18	605	24	210	8
	2,49:1	0,0153	0,0208	50	67	55	75											
SD 12	2,23:1	0,0188	0,0256	60	82	68	92	3800	40	88	378	15	463	18	605	24	210	8
	2,49:1	0,0188	0,0256	60	82	68	92											

**ZF Padova S.r.l.**  
Via Penghe, 48  
I - 35030 Caselle di Selvazzano (PD)  
ITALY  
Phone +39 049 8299 311  
Fax +39 049 8299 550  
[www.zf.com](http://www.zf.com)



**Driveline and Chassis Technology**



03 75 007 0910 - September 2010