

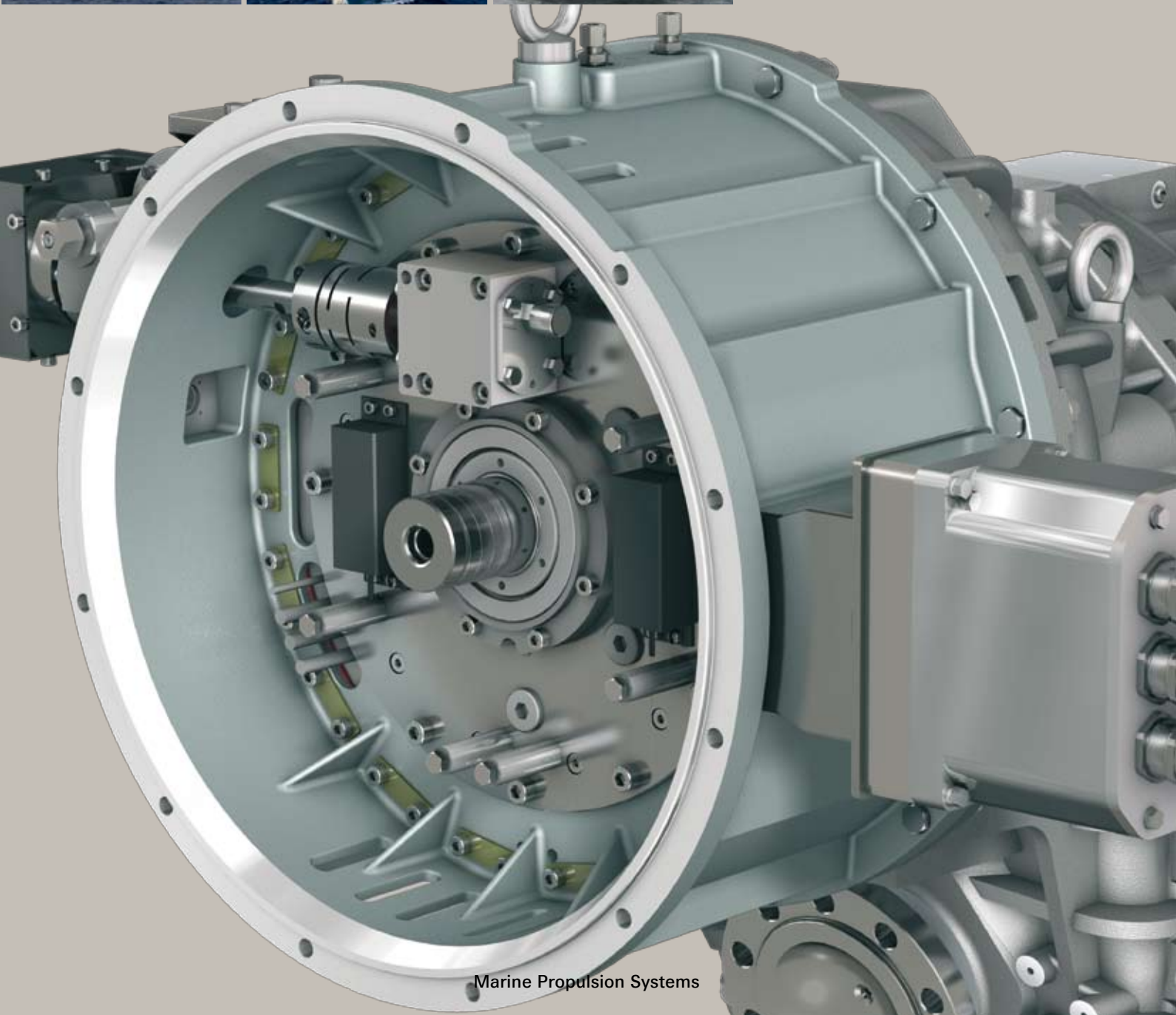

Hybrid Technology Marine Propulsion



Pleasure Craft

Marine hybrid propulsion solutions

In the past year ZF Marine has developed in close cooperation with selected shipyards numerous parallel hybrid propulsion solutions for luxury motor yachts and sailboats. Centerpieces of this development are the hybrid modules, Vessel Management Unit and power management units.

They can be matched not only to traditional transmissions for shaftline applications but also to Pod Drive Systems, such as the ZF POD 2500. These innovative systems allow power boats to maneuver silently and exhaust free in harbors using electric propulsion at the push of a button.

With a hybrid propulsion system several modes are available, like:

- electric propulsion only (battery powered propulsion)
- battery charging with diesel engine (no dock needed to charge batteries)
- diesel propulsion and simultaneous battery charging
- recharging battery through the propeller drag (in case of a sailboat sailing under wind)
- recharging battery at the dock

The electric motors in the hybrid modules are available at 10, 35, 50 and 70 kW to match the full range of propulsion in today's motor yachts and sailboats up to engine power of 1.500 hp.

The Power Electronics developed by ZF, caters for all electric needs on board:

- delivers energy to the electric motor in the hybrid module for propulsion
- powers all on-board appliances with voltages of 220/110 V AC
- powers all on-board instrumentation and equipment with voltages of 12/24 V DC
- provides the recharging of the batteries following the energy requirement set by the Battery Management System

ZF Marine, long known in the market place as reliable supplier of electronic control systems, provides also the the Vessel Management Unit (VMU) to coordinate all activities of the system to ensure ease of use, maximum reliability and safety of the vessel.

Hybrid Propulsion System for sail and small motor boats (50-165 HP diesel engine)

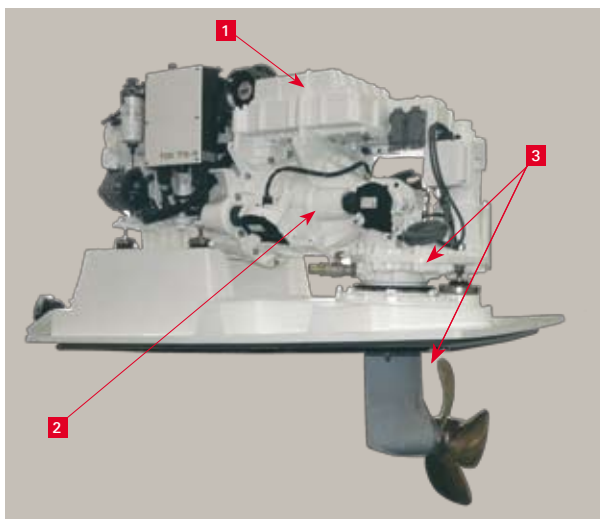

- 1 Power Electronics
- 2 Hybrid Module
- 3 Steering drive



Controls and display.

New „Hybrid Ready“ Gearbox Models

Hybrid Pod Propulsion System for motor boats

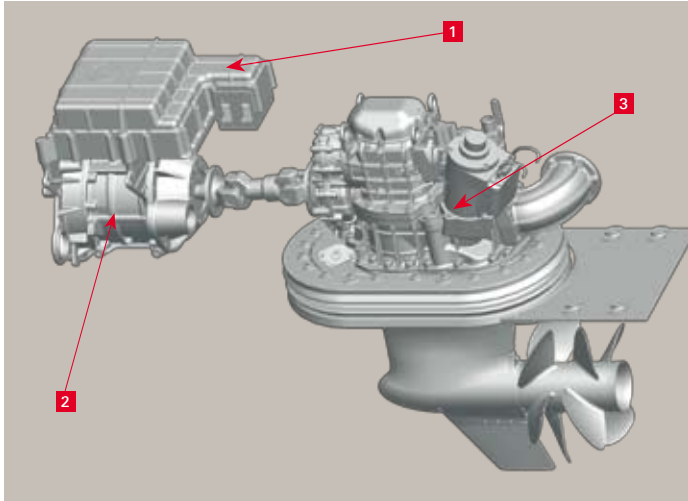

Electric power: 35, 50, 70 kW
Application with different modules on boats with diesel engines power from 300 to 1200 HP

- 1 Power Electronics
- 2 Hybrid Module
- 3 Pod Drive

Controls



Hybrid Propulsion System for motor boats

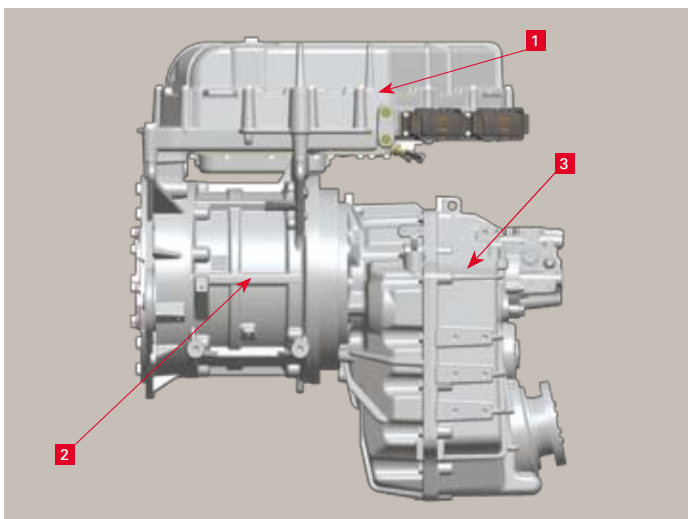

Electric power: 35, 50, 70 kW
Application with different modules on boats with diesel engines power from 75 to 1500 HP

- 1 Power Electronics
- 2 Hybrid Module
- 3 Gearbox with electric actuation

Scope of Supply

50 - 1500 HP:

- Complete propulsion package ZF including mechanical and electric components, controls and Power Electronics; battery and BMS excluded

1800 HP and above:

- ZF scope of supply
 - Gearbox
 - PTI
 - Hydraulic pack and Piping
- Scope of electrical system supplier
 - E-Motors incl. Cooling
 - Power Electronics
 - Electric Control Periphery

Electric System / Interface / Integration

50 - 1500 HP:

- ZF complete system supplier

1800 HP and above:

- Electric / mechanic Interface: Flange for E-Motor
- Preferred partnership ZF / Siemens for Hybrid Propulsion Systems over 1800 HP
- ZF System suitable also for integration with other component suppliers





Customers' Benefits

- Lower emission
 - noise
 - exhaust
 - zero emission temporarily
- Cost saving
 - fuel consumption (depending on load cycle)
 - maintenance and repair (TBO, life cycle costs)
- Enhanced comfort and operation performances
 - Maneuvering, slow speed cruising
 - Dynamic Positioning System
- Recuperation (sail boats)
- Redundancy / PTH
- Image – market trend

References

- **Mochi Craft Long Range 23**
boat show Cannes 2008, 2 x ZF 500-1V, Electric power=70kW
- **Fondation Beneteau / ZF Hybrid Propulsion Systems for Sail Boats**
Introduction: Dec. 2009 in Paris, Electric power=35kW
- **River Quest**
2 x ZF 325-1 twin input transmission for 4 E-Motors, 4 x 100kW, integrated by Siemens
- **Concept studies ZF-Siemens „Alexander v. Humboldt“**
ZF 4661 NR PTI, 746 kW Diesel / 140 kW electric power
- **Solar Sailor Hong Kong Ferries**
2 x ZF 325-1A (2 x 250 hp Diesel / 2 x 25 kW electric power)
- **Rainbow Warrior III (under construction)**
ZF W7610 NR PTI, Electric power=315 kW
- **Axis Kingship (under construction)**
ZF-Siemens hybrid solution, 2 x ZF 4661 PTI

Fast Craft

Marine transmissions for hybrid propulsion solutions

In an effort to address the market needs for hybrid propulsion for even larger vessels, ZF has developed a wide range of “hybrid-ready” transmissions for application in large fast craft. This is the culmination of continuous research and development of ZF Marine in the field of hybrid propulsion solutions.

It shows that ZF Marine takes ecologic protection concerns seriously by investing on a large scale into green technology, offering environmental protection and fuel savings to its customers, through these transmissions, which work seamlessly in hybrid solutions, offered already today by leading shipyards or which are under development.

These new hybrid propulsion solutions can be installed in most marine applications, such as Yachts, Ferries, Off-shore Supply vessels and many more. Through the unique PTI configuration and the use of standard components

it is possible to create highly efficient hybrid propulsion solutions, allowing highest flexibility for customizing installation.

A close cooperation between ZF Marine and selected partners for electric motors and the shipyards during the development of complete hybrid propulsion solutions ensures delivery of the vessel tailored to the needs of each customer. In this cooperation the partners of ZF generally provide the electrical motors and the entire electrical power periphery.

The know-how and technical experience of ZF has resulted in a state of the art product which will surely attract ship owners and fleet operators who are keen to have a comfortable, reliable, clean and quiet way of maneuvering their vessel in electric mode, through a state-of-the art hybrid propulsion system, made possible with products from ZF Marine.

ZF 5300 PTI with Spur Gear



Base gearbox ratio [-]	PTI Spur Gear (SG) ratio [-]	PTI total ratio [-] 4th shaft w/o SG	PTI total ratio [-] 4 th shaft with SG
Acc. Selection guide: 2,947 - 5,148	0,846	3,200	2,707 - 17,133 = 4th shaft ratio x SG ratio
	1,000	3,625	
	1,256	3,688	
	1,500	4,103	
	1,743	4,481	
	1,969	4,920	
	2,233	5,435	
	2,519	5,478	
	2,760	5,792	
	2,958	6,364	

ZF 9350 PTI with Spur Gear



Base gearbox ratio [-]	PTI Spur Gear (SG) ratio [-]	PTI total ratio [-] 4th shaft w/o SG	PTI total ratio [-] 4 th shaft with SG
Acc. Selection guide: 3,034 - 5,185	0,846	3,520	2,978 - 18,825 = 4th shaft ratio x SG ratio
	1,000	3,750	
	1,256	4,128	
	1,500	4,476	
	1,743	4,450	
	1,969	5,105	
	2,233	5,474	
	2,519	5,789	
	2,760	5,950	
	2,958	6,364	

ZF 24300 SG with PTI

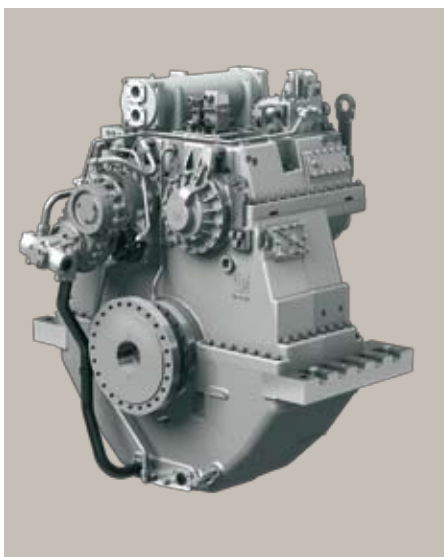

Base gearbox ratio [-]	PTI Spur Gear (SG) ratio [-]	PTI total ratio [-] w/o SG	PTI total ratio [-] with SG
Acc. Selection guide: 1,514 - 6,421	1,000	Acc. Base Gearbox: 1,514 - 6,421	1,514 - 16,984 =Base Gearbox ratio x SG ratio
	1,260		
	1,511		
	1,756		
	1,974		
	2,257		
	2,500		
	2,645		

ZF Padova S.r.l

Via Penghe, 48

I - 35030 Caselle di Selvazzano (PD)

ITALY

Phone +39 049 8299 311

Fax +39 049 8299 550

www.zf.com



Driveline and Chassis Technology