



Commercial Craft Propulsion Systems



ZF Marine Group

Your propulsion system partner

ZF Marine is the Marine Propulsion Systems business unit of the ZF Group – a multi-billion, international conglomerate specializing in drive-line and chassis technology for the automotive industry, with headquarters at ZF Friedrichshafen AG, Germany.

The marine headquarters is at ZF Padova SpA, which is also a manufacturing location producing transmissions for Commercial Craft and Pleasure Craft segment, as well as other products and components.

In addition, transmissions are produced for special applications, including marine and industrial gas turbine prime movers. This company also manufactures many of the gear wheels and pinions for distribution to other group companies.

Since 1998, ZF Marine's strategy has been to expand the product portfolio and enter new markets, particularly the Commercial Craft segment. This has been successfully achieved through acquisitions and new product design and development. Transmissions can now be offered for

Pleasure Craft



ZF Padova S.r.l.
Via Penghe, 48
I - 35030 Caselle di Selvazzano (PD)
ITALY
Tel. +39 049 8299 311
Fax +39 049 8299 550



ZF Padova S.r.l.
Via S. Andrea, 16
I - 38062 Arco (TN)
ITALY
Tel. +39 0464 580 555
Fax +39 0464 580 544



ZF Marine Electronics LLC
12125 Harbour Reach Drive, Suite B
Mukilteo, WA 98275
USA
Tel. +1 425 583 1900
Fax +1 425 493 1569



ZF-Faster Propulsion System Co.Ltd.
17, Ta Yu 1st Street
Ta Fa Industrial District - Ta Liao Hsiang
83163 Kaohsiung Hsien
TAIWAN R.O.C.
Tel. +886-7-78718 31
Fax +886-7-78718 33

Fast Craft



ZF Marine GmbH
Ehlersstr. 50
D - 88046 Friedrichshafen
GERMANY
Tel. +49 (0)7541 77 2207
Fax +49 (0)7541 77 4222



ZF Marine Electronics LLC
12125 Harbour Reach Drive, Suite B
Mukilteo, WA 98275
USA
Tel. +1 425 583 1900
Fax +1 425 493 1569



ZF-Faster Propulsion System Co.Ltd.
17, Ta Yu 1st Street
Ta Fa Industrial District - Ta Liao Hsiang
83163 Kaohsiung Hsien
TAIWAN R.O.C.
Tel. +886-7-78718 31
Fax +886-7-78718 33



ZF Marine Zhuhai Co.,LTD
No.88 Guangxin Road,Pingsha District
Zhuhai, 519055
P.R.CHINA
Phone: +86 756 7727398
Fax: +86 756 7752619

engine powers up to 14,000 kW, complete with matching fixed or controllable pitch propellers and electronic control systems.

ZF Marine has also implemented an ongoing improvement process in order to meet the various needs of customers in the Pleasure, Fast and Commercial Craft market segments.

The statement "Coming Closer to our Customers" is not an empty slogan, but a commitment to work together with engine manufacturers, shipyards, boat owners and operators to provide the best possible products and services - worldwide.

Roland Heil
ZF Marine Group CEO



Commercial Craft



ZF Padova S.r.l.
Via Penghe, 48
I - 35030 Caselle di Selvazzano (PD)
ITALY
Tel. +39 049 8299 311
Fax +39 049 8299 550



ZF do Brasil Ltda.
Avenida Conde Zeppelin 1935
CEP 18103-000 Sorocaba-SP
BRASIL
Tel. +55 15 4009 2389
Fax +55 15 4009 2233



ZF Marine Electronics LLC
12125 Harbour Reach Drive,
Suite B
Mukilteo, WA 98275
USA
Tel. +1 425 583 1900
Fax +1 425 493 1569



ZF Marine Zhuhai Co.,LTD
No.88 Guangxin Road,Pingsha District
Zhuhai, 519055
P.R.CHINA
Phone: +86 756 7727398
Fax: +86 756 7752619



ZF Marine Krimpen B.V.
Zaag 27,
2931 LD Krimpen a/d Lek
The Netherlands
Phone: +31 180 3310 00
Fax: +31 180 3310 99

Sales & Service Organization

ZF Marine LLC
(North America Headquarters, responsible also for
Mexico, Central America and the Caribbean)
15351 SW 29th St Suite 300,
Miramar/FL 33027
USA
Tel. +1 954 441 4040
Fax +1 954 447 4141

ZF Padova S.p.A. Shanghai Representative Office
Room 2206-08, Jiangnan Building, No. 600 Luban Road
Shanghai, 200023
P.R. CHINA
Tel. +86-21-6301 4338
Fax +86-21-6301 6449

ZF Marine Middle East LLC
Office No. 502 & 503, Golden Tower
Buhaira Corniche
Sharjah
U.A.E.
Tel. + 971 6 5747 074
Fax + 971 6 5747 174

ZF Marine Singapore
20 Harbour Drive
#06-01 PSA Vista
Singapore 117612
Rep. of SINGAPORE
Tel. + 65 677 37 551
Fax + 65 677 37 537

ZF Marine Eurasia LLC
Adil Mahallesi, Demokrasi Cad. No:17,
TUR 34935 Sultanbeyli - Istanbul
TURKEY
Tel. + 90 216 592 2211
Fax + 90 216 592 1244

In addition, ZF Marine is supported by 500 Sales & Service offices worldwide.

See www.zf.com/marine, for contact details

The Marine Propulsion experience –

Turnkey solutions!

Experience is what counts in a harsh unforgiving marine environment, and ZF Marine has been exposed to such elements for over 50 years!

As a truly international supplier of marine propulsion systems, with design and production facilities in six countries and an extensive sales and service network, ZF Marine is well

positioned to serve all your propulsion requirements.

World-renowned for high quality, high performance transmissions ideally suited to applications in all types of fast craft, particularly luxury motor yachts and defense vessels, the company has steadily expanded its marine activities into the commercial vessel market.



Over the past ten years, by means of internal design and development, as well as acquisitions, the power capacity of ZF Marine products has been increased to satisfy the requirements of specialized work boats such as fishing boats, tugs and inland waterway vessels.

In addition, using advanced development techniques and a modular design concept, a family of gearboxes was created especially for medium-speed Diesel installations with power ratings up to 16 MW which are typically installed in ocean going vessels.

Today, ZF Marine is recognised as a supplier of compact, light-weight transmissions for fast craft, as well as heavy duty gearboxes for all types of commercial vessels.

ZF Marine's controllable pitch propeller (CPP) experience stretches over thirty years and grew out of the tough and demanding Spanish fishing industry. From those roots, modern and mature products have been developed to match today's high-tech medium-speed diesel engines, and with the reliability demanded by a competitive marine transportation industry.

ZF Marine HRP produces state-of-the-art electronic control systems for propulsion systems installed in commercial vessels for azimuth thrusters, tunnel thrusters and CPP propulsion systems.

Marine propulsion packages are the logical outcome of ZF Marine's vision to establish a turn-key customer service. This means a single source and single responsibility for azimuth

thrusters, tunnel thrusters, transmissions, shaft lines, bearings, propellers, control systems and all associated accessories. ZF Marine's experienced professionals develop fully integrated systems according to individual customer requirements which help to add value to our customer's enterprises!

Today, ZF Marine products are in operation in vessels worldwide.



ZF Marine offers...

Integrated propulsion packages: with transmissions, shaft lines, stern tubes, CPP or FPP propellers and nozzles.

Transmissions: a comprehensive range of high quality transmissions for all types of vessels.

Azimuth Thrusters: well mounted, deck mounted and retractable units.

Tunnel Thrusters: for stern- and bow thrusters applications.

Rudder systems: different type according to application.

Stern tube systems: oil- or water-lubricated stern tubes with white metal or rubber bearings and seals.

Nozzles: standard designs such as type 19A or type 37 for improved astern operation and high efficiency nozzles.

Control systems: electronic or pneumatic control systems.

Shaft brakes: pneumatic-over-hydraulic systems for dynamic braking or for holding only.

Propellers: Controllable Pitch Propeller, Fix Pitch Propeller.

Products Description

Reversing and non-reversing transmissions

The ZF Marine organization can take advantage of the vast experience coming from the parent company, ZF Friedrichshafen AG, one of the world's leading suppliers to the automotive industry.

The ZF Group's R & D facilities have been available during the development of a series of modern reduction gearboxes which incorporate state-of-the-art tooth design to achieve low noise signature and high load transmission capabilities.

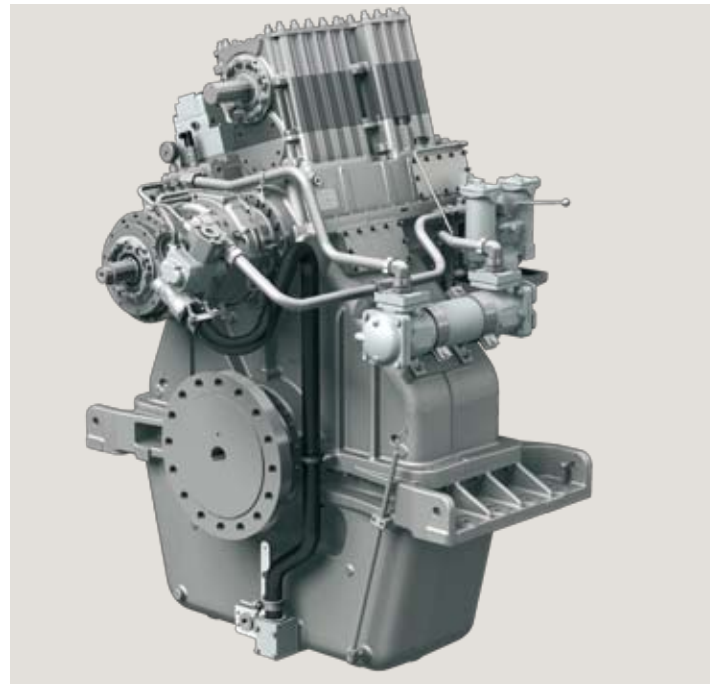
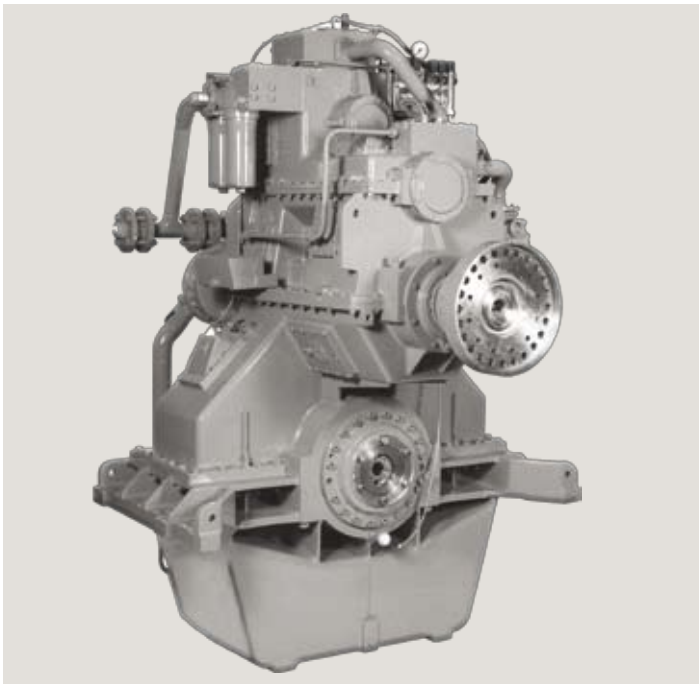

The gearbox housings are extremely resistant to torsional stresses and are generously sized to safely transmit the thrust loads to the ship's foundation.

The steel composition is according to ZF's own "Class 1A" specification which is well known and accepted throughout

the industry. The gearbox models are available with or without engaging clutches (types NR and NC) and also with a wide range of Power Take Off (PTO) and Power Take In (PTI) secondary drives. Also reversible gearboxes are now available with lots of accessories. They are suitable for FOO applications.

Thruster Systems

ZF Marine HRP has more than 30 years of experience in building azimuth thrusters. The company has designed, produced and commissioned various types of thrusters, for a multitude of applications around the world, bringing

ZF Marine HRP the reputation of a reliable and renowned thruster supplier. All thrusters are developed, designed and produced in house and built in accordance with high quality standards, guaranteeing the reliability of the product.



Well mounted steerable azimuth thruster units to be placed below deck



Steerable azimuth thrusters with counter-rotating propellers which guarantee higher efficiency and comfort on board



Deck mounted thruster units placed on deck, with containerised prime mover



Retractable Thrusters mostly used as auxiliary or back up propulsion specially designed for offshore applications like OSVs and PSVs



Shallow Draught Thrusters



Tunnel thrusters for stern and bow thruster applications

Propulsion Control Systems

ZF Marine propulsion control systems are based on decades of experience in marine control system design and are therefore at the leading edge of marine electronics technology, providing ideal solutions for single engine, multiple engine or multi station installations.

Being a crucial element for vessel and crew safety, ZF Marine control systems incorporate only reliable, well designed components and provide for easy operation and easy maintenance.



Control systems from ZF Marine interface with mechanically or electronically controlled engines, thrusters, transmissions and auxiliary systems. In particular, the electronic control systems for CPP's can be supplied for either constant speed operation or combined mode operation.

Using its own technology gained through the years, interfaces can be made to DP Systems, Autopilot, Single Joystick systems and VCR units. Customized programming is also available for special applications. The number, location (bridge, engine control room or bridge wings) and layout of

the control panels is customized to meet the application and operational constraints.

For thrusters solutions the hydraulic power pack for steering and / or lifting is mounted near the thruster and hooked up by means of hydraulic hoses and piping.

The hydraulic pump is driven by the inputshaft of the thruster, or by a constant speed electric motor. The power pack is as a standard provided with filters, clogging indicator, valves, level indicator etc. and fulfils the rules and regulations of any classification society.

ZF Marine manufactures multiple levels of commercial grade propulsion control systems to meet the various needs and requirements of commercial vessel operators. From the most basic tug boat to large double ended Ferries, our state of the art control systems are designed for the harsh engine room environment. Military Vessels and Offshore Supply Vessels, which demand highly sophisticated Dynamic

Positioning systems, are today equipped with ZF Marine propulsion control systems.

ZF Marine control systems are available for mechanical or electronic engine and transmission applications, and are designed and tested to meet stringent classification society standards.



Standard features

- Plug in Installation
- Push button configuration
- Start interlock
- Multiple Transmission protection functions
- Synchronization
- Warm up mode
- Multiple control station capability with simple station transfer

CPP and FPP propulsion packages

Turnkey responsibility for the propulsion drive-line offers many benefits, not only during project conception

and system commissioning but also for service support throughout the vessel's life!



Benefits

- Optimized design through careful matching of gearbox and propeller to the hull and engine characteristics. ZF Marine's design experts work closely with ship designers, shipbuilders and engine manufacturers during the project phase, construction period and are available for analysis of sea-trial results.
- Standardization of propulsion components results in simple systems, easy maintenance and increased reliability. ZF Marine utilizes their well-proven controllable pitch propeller hub design for all applications, from small fast craft up to large product tankers.
- Simplified installation, with no "hidden costs" or unexpected exclusions to the scope of supply.
- ZF Marine service engineers are commissioning experts for propellers, gearboxes and all associated components, hydraulic and electronic systems.
- Package with fixed pitch propeller is available with 4 or 5 blades up to Ø 6 m

The new Controllable Pitch Propeller KS-Series has a unique design, based on the long-standing experience of ZF Marine in the field of propulsion systems for commercial vessels.

The new KS propeller series combines propulsion efficiency and ease of installation with state-of-the-art technology.



The hub profile has been hydro-dynamically improved, leading to better fuel efficiency of the vessel. Assembly and servicing is simplified, as access to internal components is possible from the back of the hub. The range of available propeller hubs has been increased from the previous KH-Series with 11 models to now 20 models for the new KS-Series. With the new KS-Series propellers double sealing between hub and propeller base is now standard, improving significantly sealing efficiency. The new KS-Series controllable pitch propellers are available up to 7,75 m

The controllable pitch propellers of the new KS-Series from ZF Marine have a reduced hub/prop diameter ratio for better hydrodynamic efficiency, larger hub diameter family for optimized selection, easier maintenance, a more compact hub design, achieved through an equilibrated choice of components.

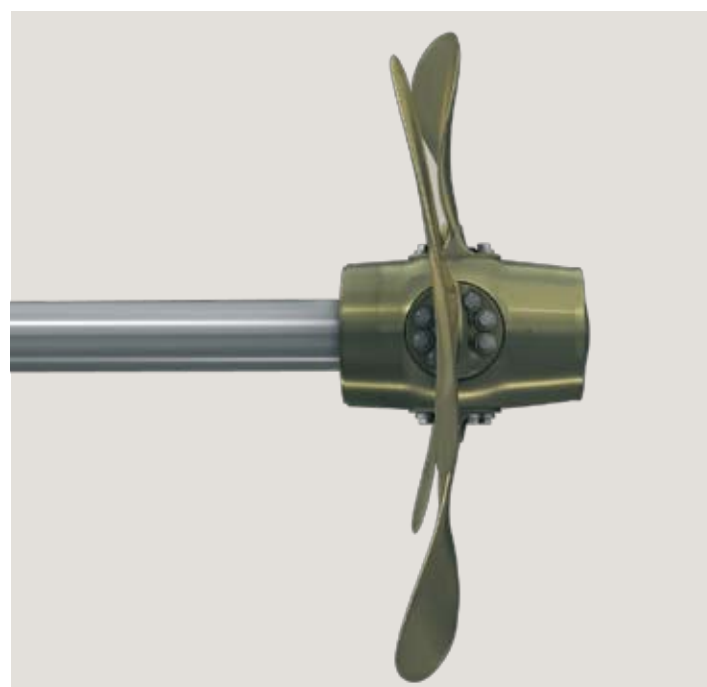

diameter with hub diameter of 1,55 m, with custom designed propeller blades to maximize efficiency and can be matched to engines from 350 kW to 16.000 kW.

The oil distribution box, as an important part of each controllable pitch propeller propulsion system, has been made more compact and much lighter, compared to the previous versions. Installation has been made easier. Easier installation and increased maximum allowed rpm, are further improvements worth mentioning.

CPP & Internal Components

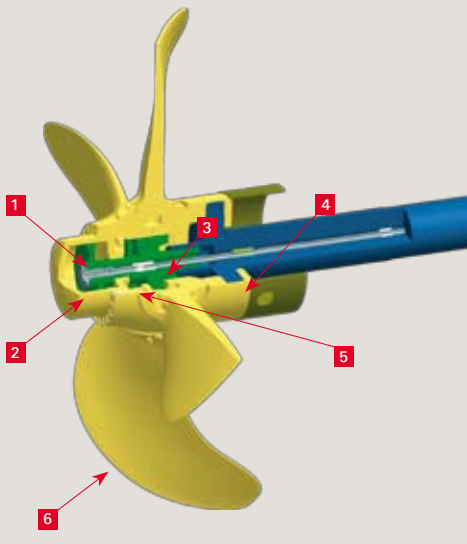

KH and KS Series

Hub details for KH and KS versions

- 1 Robust, solid hub with large blade ports
- 2 Servo cylinder inside hub
- 3 Double sealing system for environmental safety
- 4 Hydraulic oil tubes, available with single or double pipe
- 5 Robust, single piece yoke-piston rod arrangement
- 6 Optimized, "wake-adapted" blade design for high efficiency, low noise performance

Twin pump hydraulic system with proportional valve

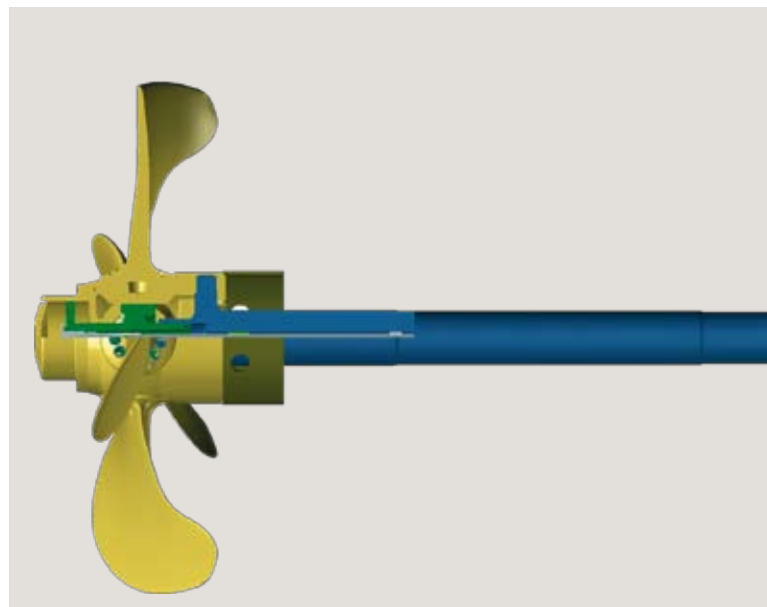

Transmissions details

- 7 Gearbox with or without disengaging clutch (type NR and NC).
- 8 Integrated hydraulic pump (standby pump loose or fitted on gearbox)
- 9 PTO assembly: Primary and secondary PTO's with or without clutch.
- 10 Centralized and ergonomic alarm and monitoring group.
- 11 Integrated hydraulic control unit.
- 12 Hydraulically fitted flange coupling with integrated drive-up piston.
SKF-coupling option for plane bearings Gearbox

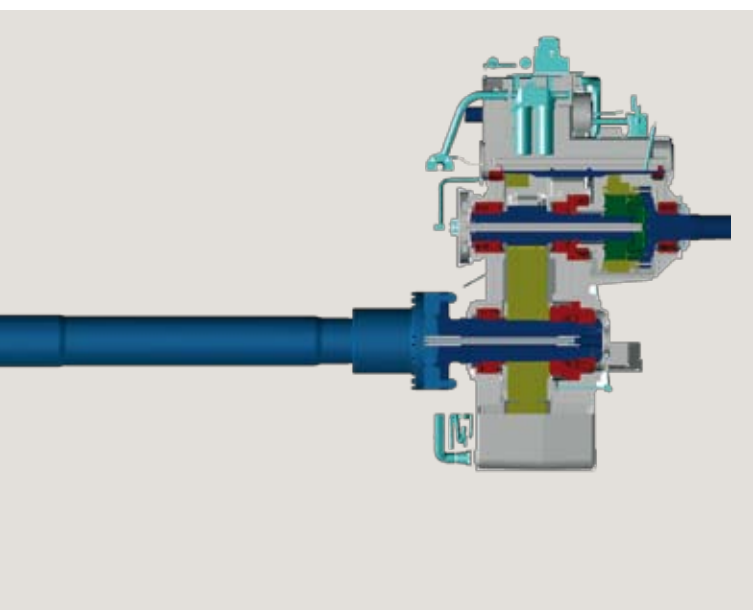
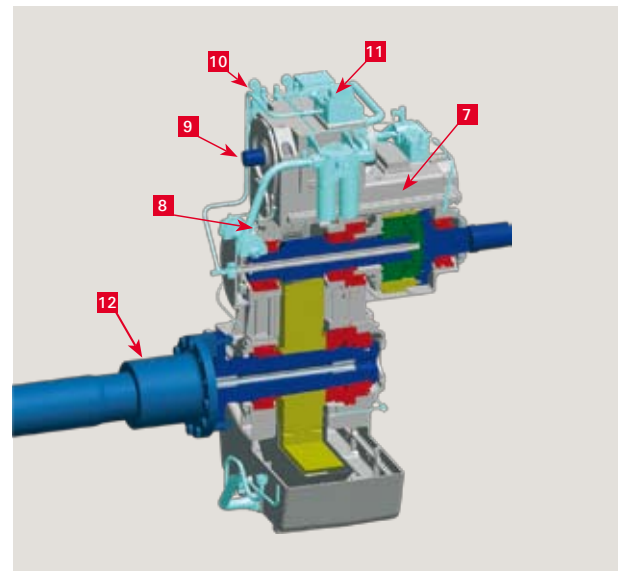

OD box - KH Series

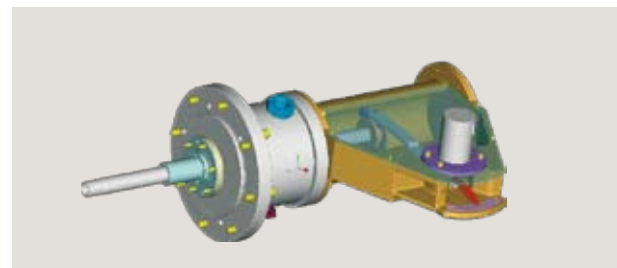

OD box - KS Series

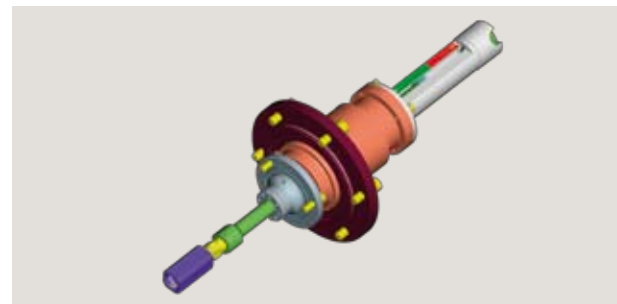

Technical Data

Thrusters

Well Mounted Azimuth Propulsion Thrusters

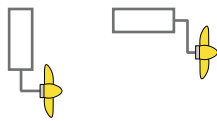
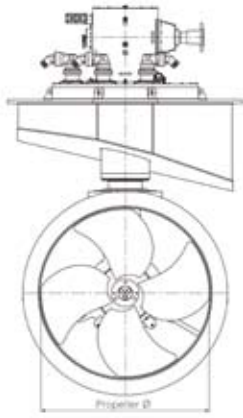

Model	Max. power*		Typical prop. dia. open		Typical prop. dia. nozzle	
	kW	hp	mm	inch	mm	inch
ZF AT 2000 WM-FP	200	272	750	30	700	28
ZF AT 3000 WM-FP	300	408	1050	41	1000	39
ZF AT 400 WM-FP	440	598	1150	45	1100	43
ZF AT 4000 WM-FP	525	714	1350	53	1300	51
ZF AT 5000 WM-FP	850	1156	1700	67	1650	65
ZF AT 6000 WM-FP	1200	1632	1950	77	1900	75
ZF AT 7000 WM-FP	1650	2244	2300	91	2200	87
ZF AT 8000 WM-FP	2000	2720	2500	98	2400	94
ZF AT 9000 WM-FP	2700	3672	2900	114	2600	102

Contra Rotating Azimuth Thrusters

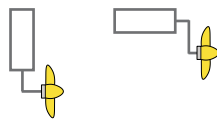
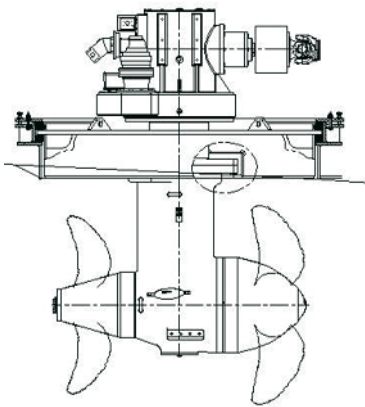

Model	Max. power*		Propeller dia. pulling propeller		Propeller dia. pushing propeller	
	kW	hp	mm	inch	mm	inch
ZF AT 2000 WM-CR	200	272	700	30	70	30
ZF AT 2000 DM-CR						
ZF AT 2000 RT-CR						
ZF AT 4000 WM-CR	525	714	1100	40	1050	40
ZF AT 4000 DM-CR						
ZF AT 4000 RT-CR						
ZF AT 5000 WM-CR	850	1156	1650	70	1580	60
ZF AT 5000 DM-CR						
ZF AT 5000 RT-CR						

Deck Mounted Azimuth Thrusters

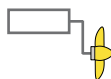
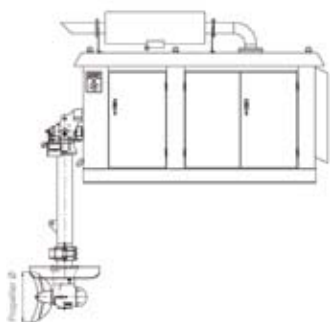

Model	Max. power*		Typical prop. dia. open		Typical prop. dia. nozzle	
	kW	hp	mm	inch	mm	inch
ZF AT 2000 DM-FP	180	245	750	30	700	28
ZF AT 3000 DM-FP	300	408	1050	41	1000	39
ZF AT 400 DM-FP	440	598	1150	45	1100	43
ZF AT 4000 DM-FP	525	714	1350	53	1300	51
ZF AT 5000 DM-FP	825	1122	1700	67	1650	65
ZF AT 6000 DM-FP	1200	1632	2100	83	2050	81

* Rating, subject to classification.

Consult ZF Marine HRP's technical staff to determine applicable power for each specific use.
Can be supplied with any type or make of diesel engine

Retractable Azimuth Thruster

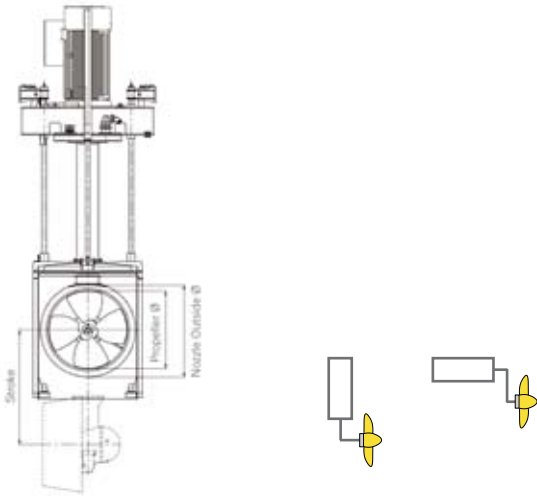

Model	Max. power*		Typical prop. nozzle dia.	
	kW	hp	mm	inch
ZF AT 2000 RT-FP	200	272	700	28
ZF AT 3000 RT-FP	300	408	1000	39
ZF AT 400 RT-FP	440	598	1100	43
ZF AT 4000 RT-FP	525	714	1300	51
ZF AT 5000 RT-FP	850	1156	1650	65
ZF AT 6000 RT-FP	1200	1632	1900	75
ZF AT 7000 RT-FP	1650	2244	2200	87
ZF AT 8000 RT-FP	2000	2720	2400	94

Shallow Draught Thrusters

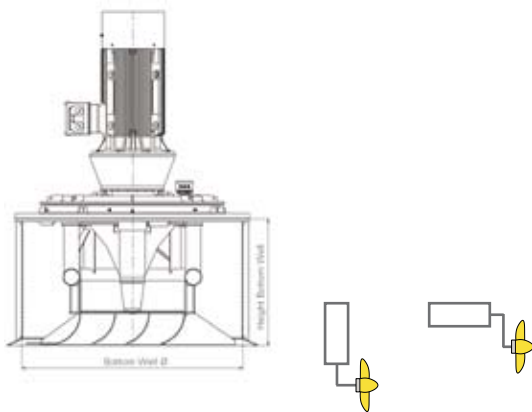

Model	Max. power*		Diameter outer well approx.		Height of outer well approx.	
	kW	hp	mm	inch	mm	inch
ZF SDT 2000 FP	100	130	1030	41	615	24
ZF SDT 3000 FP	195	260	1460	58	867	34
ZF SDT 4000 FP	350	470	1960	77	1158	46
ZF SDT 5000 FP	575	770	2520	99	1493	59
ZF SDT 6000 FP	850	1140	3060	121	1805	71

*Rating, subject to classification.
Consult ZF Marine HRP's technical staff to determine applicable power for each specific use.

Technical Data

Thrusters

Fixed Pitch Tunnel Thrusters

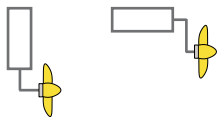
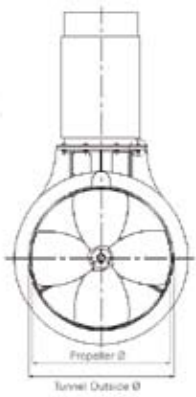

Model	Max. power*		Typical prop. dia.		Tunnel outer dia.		Tunnel wall thickness stand.		Tunnel length standard	
	kW	hp	mm	inch	mm	inch	mm	inch	mm	inch
ZF TT 1000 FP**	100	136	600	24	660	26	15	0,6	1000	39
ZF TT 2000 FP**	200	272	700	28	760	30	15	0,6	1000	39
ZF TT 3000 FP	300	408	1050	41	1110	44	15	0,6	1000	39
ZF TT 400 FP	440	598	1150	45	1220	48	15	0,6	1000	39
ZF TT 4000 FP	525	714	1350	53	1420	60	16	0,6	1500	59
ZF TT 5000 FP	850	1156	1650	65	1730	70	18	0,7	2000	79
ZF TT 6000 FP	1200	1632	1900	75	1990	80	20	0,8	2000	79
ZF TT 7000 FP	1650	2244	2300	91	2400	90	22	0,9	2200	80
ZF TT 8000 FP	2000	2720	2450	97	2550	100	22	0,9	2550	100

Controllable Pitch Tunnel Thrusters

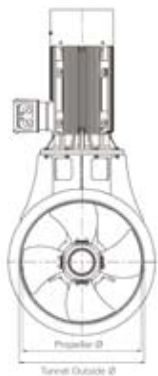

Model	Max. power*		Typical prop. dia.		Tunnel outer dia.		Tunnel wall thickness stand.		Tunnel length standard	
	kW	hp	mm	inch	mm	inch	mm	inch	mm	inch
ZF TT 4000 CP	500	670	1350	53	1420	60	16	0,6	1500	59
ZF TT 5000 CP	850	1164	1650	65	1730	70	18	0,7	2000	79

*Rating, subject to classification.

Consult ZF Marine HRP's technical staff to determine applicable power for each specific use.

**Also available in AI. gearbox and tunnel

Transmissions

Reversing and Non-reversing Transmissions - Vertical Offset

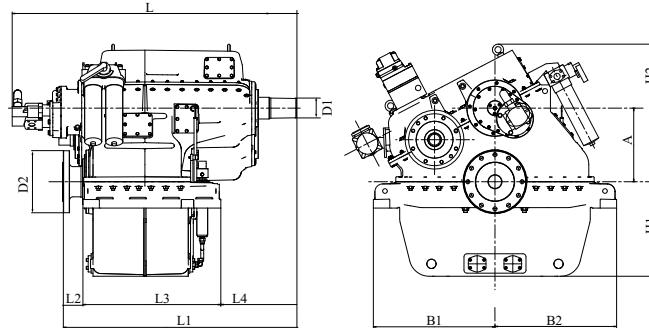

	Dimensions mm/inches											Weight (dry) Approx	
	A	B1+B2	H1	H2	L	L1	L2	L3	D1	D2	Kg	lb	
ZF W11000	415 16,3	1300 51,2	530 20,9	830 32,7	1562 61,5	1210 47,6	117 4,6	714 28,1	112 4,4	420 16,5	2650	5830	
ZF W11000 NR	415 16,3	1300 51,2	530 20,9	830 32,7	1562 61,5	1210 47,6	117 4,6	714 28,1	112 4,4	420 16,5	2250	4950	
ZF W11100	530 20,9	1400 55,1	600 23,6	945 37,2	1562 61,5	1238 48,7	145 5,7	672 26,5	112 4,4	450 17,7	3100	6820	
ZF W11100 NR	530 20,9	1400 55,1	600 23,6	945 37,2	1562 61,5	1238 48,7	145 5,7	672 26,5	112 4,4	450 17,7	2700	5940	
ZF W11200	660 26,0	1650 65,0	688 27,1	1075 42,3	1562 61,5	1238 48,7	145 5,7	714 28,1	112 4,4	540 21,3	3700	8140	
ZF W11200 NR	660 26,0	1650 65,0	688 27,1	1075 42,3	1562 61,5	1238 48,7	145 5,7	714 28,1	112 4,4	540 21,3	3300	7260	
ZF W17000	475 18,7	1570 61,8	610 24,0	944 37,2	1818 71,6	1504 59,2	127 5,0	890 35,0	129 5,1	400 15,7	4550	10010	
ZF W17000 NR	475 18,7	1570 61,8	610 24,0	944 37,2	1818 71,6	1504 59,2	127 5,0	890 35,0	129 5,1	400 15,7	3900	8580	
ZF W17100	600 23,6	1700 66,9	725 28,5	1016 40,0	1818 71,6	1504 59,2	117 4,6	925 36,4	129 5,1	500 19,7	5350	11770	
ZF W17100 NR	600 23,6	1700 66,9	725 28,5	1016 40,0	1818 71,6	1504 59,2	117 4,6	925 36,4	129 5,1	500 19,7	4750	10450	
ZF W17200	700 27,6	1700 66,9	825 32,5	1167 45,9	1818 71,6	1504 59,2	117 4,6	925 36,4	129 5,1	600 23,6	5800	12760	
ZF W17200 NR	700 27,6	1700 66,9	825 32,5	1167 45,9	1818 71,6	1504 59,2	117 4,6	925 36,4	129 5,1	600 23,6	5250	11550	

For any further detail regarding ZF W11000 and ZF W17000 family, please refer to ZF Selection Guide.

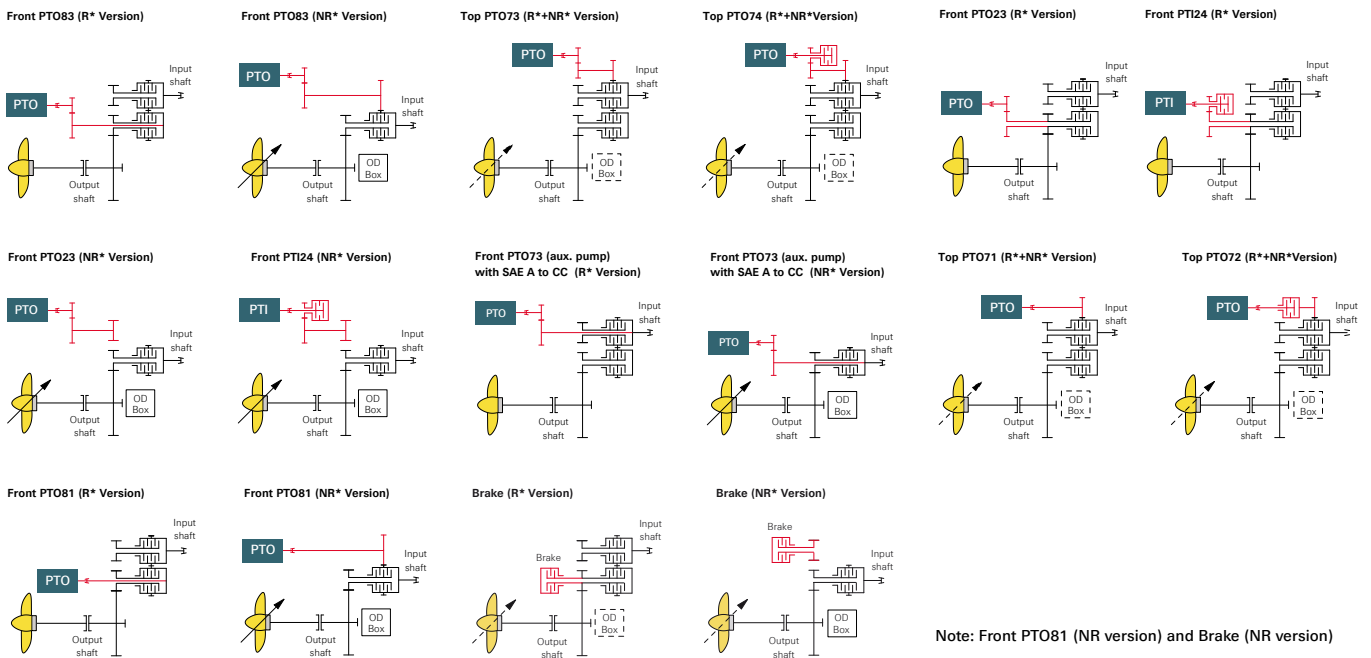

*R= Reversing *NR= Non-Reversing

Technical Data

Transmissions

Non-reversing Transmissions, with clutch (Type NR)

Vertical Offset

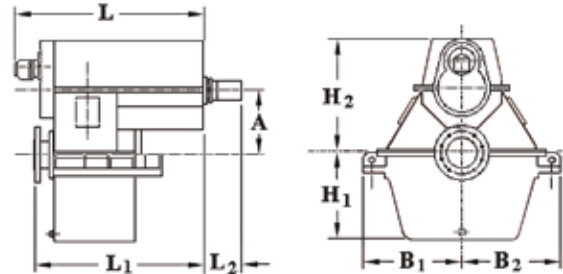

Model	Dimensions mm/inches									Weight (dry) Approx	
	A	B1	B2	H1	H2	L	L1	L2	Kg	lb	
ZF W23100 NR	630 24,8	810 31,9	810 31,9	710 28,0	1010 39,8	1448 57,0	1301 51,2	288 11,3	4700	10340	
ZF W33100 NR	700 27,6	860 33,9	860 33,9	800 31,5	1260 49,6	1596 62,8	1493 58,8	301 11,9	6080	13376	
ZF W43000 NR	600 23,6	860 33,9	860 33,9	800 31,5	1210 47,6	1768 69,6	1598 62,9	336 13,2	6400	14080	
ZF W43100 NR	770 30,3	995 39,2	995 39,2	900 35,4	1380 54,3	1768 69,6	1653 65,1	336 13,2	9300	20460	
ZF W63000 NR	670 26,4	995 39,2	995 39,2	900 35,4	1367 53,8	1836 72,3	1785 70,3	346 13,6	9200	20240	
ZF W83100 NR	980 38,6	1230 48,4	1230 48,4	1120 44,1	1760 69,3	1989 78,3	2059 81,1	376 14,8	16600	36520	
ZF W93300 NR*	980 38,6	1235 48,6	1235 48,6	1125 44,3	2438 96,0	3124 123	3415 135	270 10,6	23800	52360	

* PTO3 not available

PTO73 (old PTO3-Live)

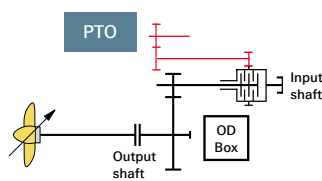

PTO14 (old PTO4-Clutchable)

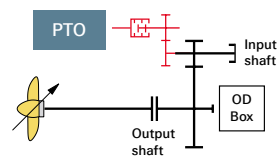

Horizontal Offset

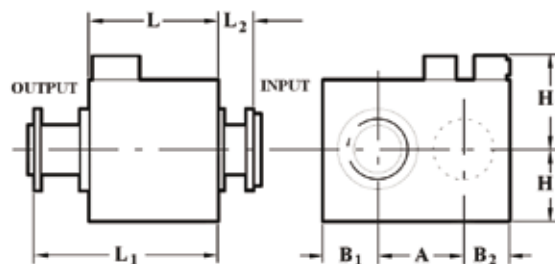

Model	Dimensions mm/inches									Weight (dry) Approx	
	A	B1	B2	H1	H2	L	L1	L2	Kg	lb	
ZF W63000 NR2H	670 26,4	948 37,3	772 30,4	770 30,3	1146 45,1	1531 60,3	1768 69,9	364 14,3	9900	21780	

Non-reversing Transmissions, without clutch (Type NC)

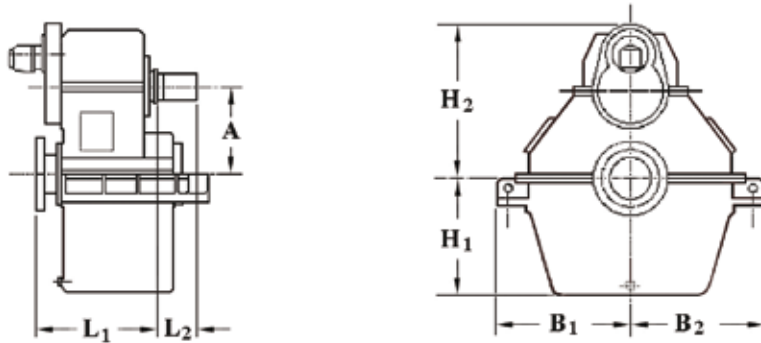

Model	Dimensions mm/inches								Weight (dry) Approx							
	A		B1		B2		H1		H2		L1		L2		Kg	lb
ZF W23100 NC	630	24,8	810	31,9	810	31,9	710	28,0	1120	44,1	790	31,1	250	9,80	3800	8360
ZF W33100 NC	700	27,6	860	33,9	860	33,9	800	31,5	1350	53,1	880	34,6	290	11,4	4500	9900
ZF W43000 NC	600	23,6	860	33,9	860	33,9	800	31,5	1255	49,4	930	36,6	340	13,4	5400	11880
ZF W43100 NC	770	30,3	995	39,2	995	39,2	900	35,4	1432	56,4	985	38,8	340	13,4	6800	14960
ZF W83000 NC	750	29,5	1090	42,9	1090	42,9	1000	39,4	1562	61,5	1130	44,5	360	14,2	9270	20394
ZF W83100 NC	980	38,6	1230	48,4	1230	48,4	1120	44,1	1792	70,6	1210	47,6	360	14,2	14800	32560
ZF W93100 NC	980	38,6	1230	48,4	1230	48,4	1120	44,1	1792	70,6	1210	47,6	360	14,2	15800	34760
ZF W93300 NC	980	38,6	1235	48,6	1235	48,6	1125	44,3	2140	84,2	2490*	98,0	425	16,7	21000	46200
ZF W103100 NC	1120	44,1	1375	54,1	1375	54,1	1340	52,7	1810	71,3	2190*	86,2	425	16,7	27000	57200

*cylindrical outputshaft without flange

PTO14 (old PTO4-Clutchable)

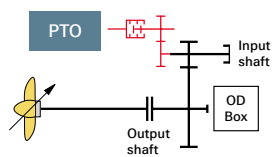

PTO13 (old PTO5-Live)

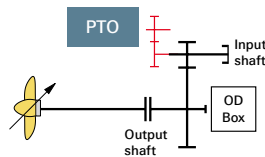

Technical Data

Controllable Pitch Propeller

KH Series

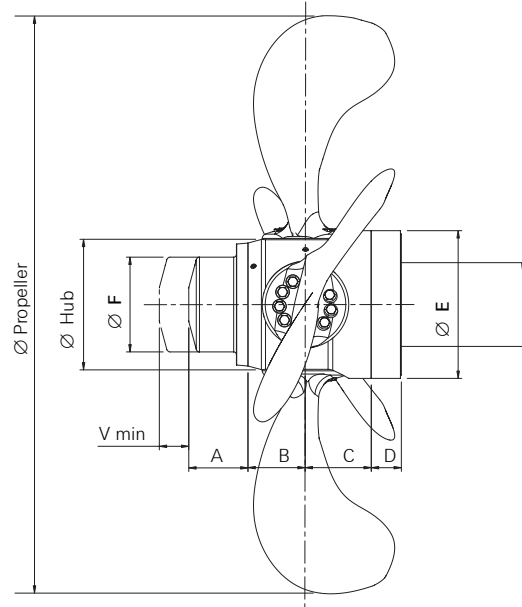

Model	MAX prop. Dia.		Hub Propeller		A		B		C		D		Ø E		Ø F		V min		
	mm	inch	mm	inch	mm	inch	mm	inch	mm	inch	mm	inch	mm	inch	mm	inch	mm	inch	
KH-425	1850	73	425	17															
KH-480	2050	81	480	19															
KH-515	2200	87	515	20	193	8	190	7	217	9	107	4	488	19	311	12	70	3	
KH-560	2400	94	560	22	208	8	207	8	236	9	118	5	530	21	341	13	70	3	
KH-600	2600	102	600	24	210	8	221	9	253	10	105	4	580	23	365	14	70	3	
KH-680	2900	114	680	27	256	10	250	10	287	11	119	5	650	26	414	16	90	4	
KH-760	3300	130	760	30	290	11	280	11	322	13	160	6	720	28	463	18	90	4	
KH-850	3700	146	850	33	323	13	314	12	359	14	177	7	806	32	517	20	100	4	
KH-960	4000	157	960	38	341	13	355	14	405	16	200	8	910	36	584	23	110	4	
KH-1070	4500	177	1070	42	389	15	394	16	451	18	210	8	1012	40	650	26	120	5	
KH-1200	5000	197	1200	47	460	18	442	17	506	20	244	10	1136	45	730	29	160	6	
KH-1350	5700	224	1350	53	576	23	500	20	570	22	300	12	1280	50	870	34	200	8	
KH-1500	6300	248	1500	59	720	28	560	22	640	25	370	15	1425	56	1036	41	240	9	

KS Series

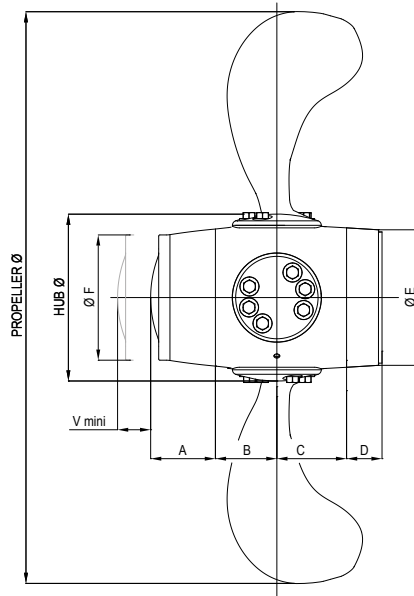

Model	MAX prop. Dia.		Hub Propeller		A		B		C		D		Ø E		Ø F		V min	
	mm	inch	mm	inch	mm	inch	mm	inch	mm	inch	mm	inch	mm	inch	mm	inch	mm	inch
KS-350	1750	69	350	14	137	5	130	5	148	6	75	3	285	11	265	10	70	3
KS-400	2000	79	400	16	157	6	149	6	169	7	86	3	326	13	303	12	80	3
KS-450	2250	89	450	18	176	7	167	7	190	7	96	4	366	14	341	13	90	4
KS-500	2500	99.8	500	20	196	8	186	7	211	8	107	4	407	16	379	15	100	4
KS-550	2750	108	550	22	215	8	204	8	232	9	118	5	448	18	416	16	110	4
KS-600	3000	118	600	24	235	9	223	9	253	10	129	5	489	19	454	18	120	5
KS-650	3250	128	650	26	254	10	241	9	274	11	139	5	529	21	492	19	130	5
KS-700	3500	138	700	28	274	11	260	10	295	12	150	6	570	22	530	21	140	6
KS-760	3800	150	760	30	297	12	282	11	320	13	163	6	619	24	575	23	152	6
KS-820	4100	161	820	32	321	13	305	12	346	14	176	7	668	26	621	24	164	6
KS-880	4400	173	880	35	344	14	327	13	371	15	189	7	717	28	666	26	176	7
KS-940	4700	185	940	37	368	14	349	14	396	16	201	8	765	30	712	28	188	7
KS-1010	5050	199	1010	40	395	16	375	15	426	17	216	9	822	32	765	30	202	8
KS-1080	5400	213	1080	43	423	17	401	16	455	18	231	9	879	35	818	32	216	9
KS-1150	5750	226	1150	45	450	18	427	17	485	19	246	10	936	37	871	34	230	9
KS-1220	6100	240	1220	48	478	19	453	18	514	20	261	10	993	39	924	36	244	10
KS-1300	6500	256	1300	51	509	20	483	19	548	22	279	11	1059	42	984	39	260	10
KS-1380	6900	272	1380	54	540	21	513	20	582	23	296	12	1124	44	1045	41	276	11
KS-1460	7300	287	1460	57	571	22	542	21	615	24	313	12	1189	47	1105	44	292	11
KS-1550	7750	305	1550	61	607	24	576	23	653	26	332	13	1262	50	1174	46	310	12



ZF Marine - one of the world's largest supplier of transmissions and propulsion systems

ZF was founded by Graf Zeppelin in 1915. To fulfil his dream to develop high technology airships, he needed lightweight, precision transmissions to match the high performance Daimler Benz engines. The company grew rapidly and soon diversified to supply the automotive industry.

The transmissions developed for the airships were ideally suited for installation in fast boats and in 1938 the first marinized version, the KS 25, was delivered to Daimler Benz. This very compact gearbox was close-coupled to the MB501 engine, transmitting 2500 hp at 1600 rpm.

Throughout the '50's and '60's many marine transmissions were developed including small mechanical shift gearboxes and larger models fitted with electromagnetic couplings. Finally, the latter were phased out in favor of hydraulically controlled transmissions.

During the '70's, the pleasure craft business increased and ZF introduced more transmissions to meet the growing demands of the engine suppliers, then in 1986, the Italian company MPM (Meccanica Padana Monteverde) was acquired. (now ZF Padova S.p.A.)

The ZF Padova transmissions complemented the Friedrichshafen products, extending the lower end of the product range and soon ZF Padova S.p.A. became the headquarters of ZF's marine products division.

In 1995, ZF acquired the Hurth group of companies and the ZF Marine group was expanded with the establishment of ZF Marine Arco, Italy, a company producing small mechanically operated transmissions and hydraulic transmissions for small pleasure craft.

In 1999, ZF Marine started to market a comprehensive range of surface-drives and trim-tabs.



In 2000, controllable and fixed pitch propellers were added to the product portfolio with the acquisition of ZF-FPS (Faster Propulsion System Co. Ltd.), Kaohsiung, Taiwan. Electronic controls systems were also added with the acquisition of ZF Marine Electronics LLC at Mukilteo WA, USA and also the world-wide Sales & Service network was expanded by founding new Sales & Service offices such as the ZF Marine Representatives Office in Shanghai, ZF Marine Middle East in Sharjah, UAE and several satellite offices in North America.

The year 2002 saw a consolidation of the ZF Marine Group, and restructuring of the organization to address specific market segments.

ZF Marine introduced the SeaRex range of trimmable surface drives augmented by the smaller MiniRex drive.

In 2005 SmartCommand, a state-of-the-art electronic controls system, was successfully introduced to the Pleasure Craft market.

Since 2002, there has been ongoing development of large transmissions suitable for commercial vessels powered by medium-speed Diesels, as well as corresponding controllable pitch propellers and associated controls.

In June 2006, a Joint Venture was established with Nanjing Highspeed & Accurate Gear (Group) Co. Ltd. in the People's Republic of China. The new company, ZF Nanjing Marine Propulsion Co. Ltd., assembles and markets products for commercial vessels and work boats worldwide.

In September 2009 ZF Marine has acquired HRP Nederland b.v. and all its subsidiaries, including production locations in the Netherlands and Indonesia as well as sales and service locations worldwide. HRP will continue in business as ZF Marine HRP within the ZF Marine Group.

ZF Marine HRP produces a wide range of steerable thrusters, which include well mounted thrusters, retractable thrusters, tunnel thrusters and controls, available in fixed pitch, CP and CRP versions.

ZF Padova s.r.l.
Via Penghe, 48
I - 35030 Caselle di Selvazzano (PD)
ITALY
Phone +39 049 8299 311
Fax +39 049 8299 550
www.zf.com



Driveline and Chassis Technology



03 98 002 1110 - November 2010