



MiniCommand





MiniCommand - Positive Control, Compact, Simple, Affordable

MiniCommand provides single lever control of electronically actuated diesel engines and marine transmissions in a robust, compact package.

Designed for pleasure craft and some light duty commercial vessels up to 50 feet in length with a maximum of two control stations, the MiniCommand control processor incorporates the logic circuits for two engines in one compact package. This single unit design allows the MiniCommand processor to fit in smaller spaces while maintaining two completely separate operating systems.

MiniCommand can be equipped with the same control heads as the MicroCommander, CruiseCommand, and ClearCommand control systems. In addition, ZF Marine Electronics introduces the new 4200 Series control head a derivative of the popular 5200 series SmartCommand control head.

MiniCommand is a reasonably priced control system having features of control systems costing significantly more. MiniCommand continues the ZF Marine Electronics tradition of making boat handling and docking easy and effortless.

Standard features of the MiniCommand system

- Start interlock - prevents the engine from starting while the transmission is in gear.
- Warm up mode - enables engine speed only with the transmission locked in Neutral. This allows the engine to get up to operating temperature more quickly in preparation for departure. Warm up mode is also useful for engine testing.
- Cruise mode - is the standard operating condition. In this mode the operator has single lever control of clutch and throttle with one lever for each engine. Two engine systems can easily be operated with one hand.
- Single lever mode - allows for twin engine operation of shift and throttle control utilizing one single lever.
- Automatic "open loop" engine synchronization - maintains the same speed on multiple engines. Engine synchronization improves fuel economy and reduces both noise and vibration.

Normal-profile 4200 Control Head



Low-profile 4200LP Control Head



MC2000 Control Head



463 Control Head



MiniCommand is suitable for one or two control station yachts.



Technical features

- Compatible with 12 or 24 volt systems.
- Diesel and gas engines.
- Maximum two stations.
- Analog throttle output (PWM, 4-20MA, 0-5V, Frequency, Dual Voltage)
- CAN Interface (available).
- Twin screw application built into one enclosure, with two microprocessors for redundancy (one for each engine and gear).
- Single lever control of transmission direction and engine speed.
- Proportional pause on emergency reversal protection.
- Two on/off solenoid outputs for transmission control (ahead and astern clutches).
- Start interlock relay contacts for safe engine start.
- Daylight viewable LEDs (light emitting diodes) for status indication.
- Audible tones for warnings and faults.
- Push buttons and display for ease in set up and troubleshooting.
- "Open loop" synchronization of engine speed.
- The MiniCommand processor is designed with side mounted plug connectors for quick and easy installations and neatly organized cable routing.

Available Options

- MiniCommand is compatible with ZF Marine Electronics 400, 700, MC2000, and 4000 series pluggable control heads. Tournament levers and handheld controls can also be utilized.
- Automatic power selector - offers increased power supply redundancy.
- "Open loop" trolling valve control - available for transmissions with electronic trolling valves. This feature controls clutch slippage for hull speeds lower than engine idle rpm. The same control heads used for clutch and throttle enable trolling valve operation in an unlimited range without additional switches. The MiniCommand processor can be ordered with or without trolling function.

MI2002
MiniCommand Processor

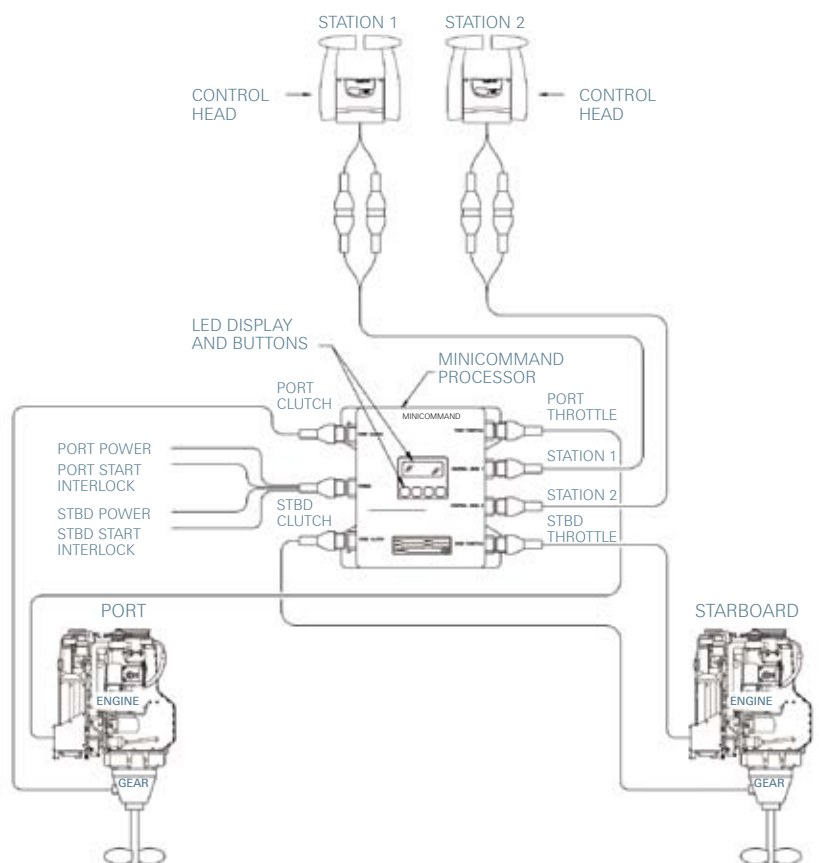

ZF Marine Electronics LLC
12125 Harbour Reach Drive
Suite B
Mukilteo, WA 98275
USA
Tel. +1 (0)425 583 1900
Fax +1 (0)425 493 1569



Driveline and Chassis Technology

Photos: Itama Forty - courtesy of Itama S.p.A.



03 07 004 0310 - March 2010