

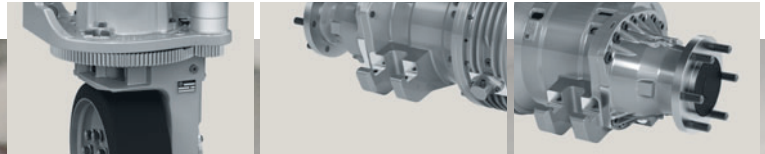



Mobile Solutions for Material Handling



Driveline Technology for
Material Handling Vehicles



Innovations of Great Value.



ZF Innovations add up! They offer advantages for the driver, carrier and manufacturer in equal measure. ZF is significantly involved in the continuous improvement of transmissions, axles and steering technology for electrically driven material handling equipment.

Today, electric counterbalanced lift-trucks achieve the same handling performance as lift-trucks with a combustion engine. Not least thanks to ZF technology, since the GP 25 and GPA 35 drive axles, for example, mark the upper end of the performance range.

Narrow warehouse aisles, stop and go, steep ramps and just-in-time transport in piecework and cycles tuned to seconds represent real challenges for a lift-truck. Particularly, the drive units are subjected to enormous stresses during daily operation. To a large extent they

determine the quality, performance capability, handling, service friendliness, and reliability of the complete vehicle.

And these are the main aspects for logistic companies as users of material handling machinery. They are under pressure of the world market to make continuous improvements in productivity, flexibility, and stability of the workflow. In innovative vehicle designs highly efficient, low-maintenance drives, almost indestructible under any load, provide a decisive contribution in this respect, just like the innovative ZF drives do.

The business unit Material Handling Systems is part of the division Industrial Technology within the ZF-Group. In this division, amongst other products, systems for engine-powered lift-truck applications from 5 to 60 t lifting capacity are developed and produced. Material Handling Systems is the specialist for drive and steering systems for electrically powered equipment, and thus completes the product range.

Consequently, for lift-trucks of all performance classes and for special applications, there is a wide and also highly specialized spectrum of innovative drive solutions available which includes the ideal transmission or complete system for all cases of material handling.

Always one step ahead with ZF drive systems

Reducing energy consumption, increasing productivity, extending service intervals, easier and better handling and more automation are all topics in the focus of ZF engineers. Take advantage of ZF's state-of-the-art technology and an extensive global supply and service network.

ZF looks back to almost 100 years worth of history in the development and production of transmissions. With this experience, the components of the ZF drive and steering systems are optimally matched to each other. And you can "hear" that – by hearing almost nothing. The low operating noise of the GPA 35 drive axle is legendary on the market already today.

With the GK-range, ZF had decisively fostered the development towards maintenance-free drive systems in industrial lift-trucks. Meanwhile all ZF drives are maintenance-free or extremely service-reduced. However, ZF does not just offer the latest technology, but also a comprehensive, worldwide supply and service network to provide planning dependability in daily practice.

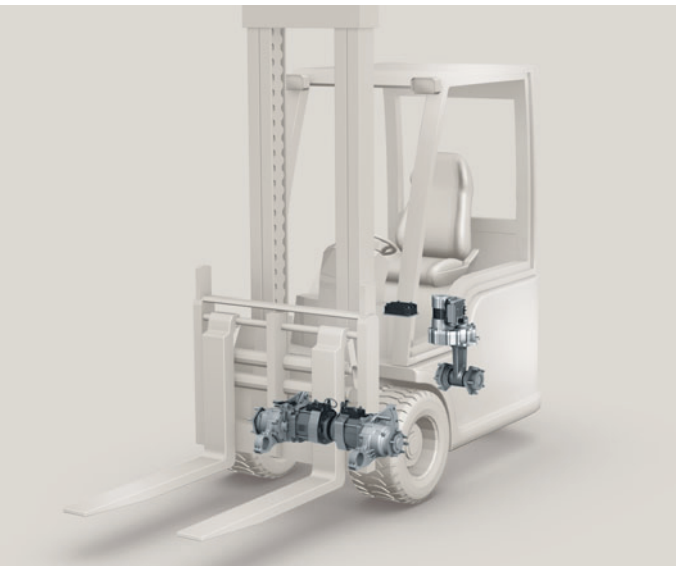

System scope in electric material handling systems

Driving, braking, steering – all pre-finished from one source. More and more lift-truck manufacturers count on high performance drive packages from ZF.

Class 1

Electric counterbalanced lift-trucks

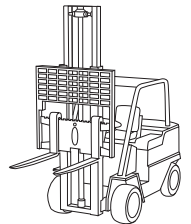

Class 2

Electric narrow aisle trucks



Class 3

Electric hand trucks

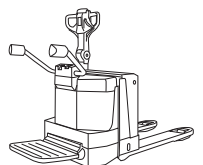



Customers benefit from ZF's system competence.

An intelligent system kit under the brand name of ZF-ERGOMAT® is being offered for the drive of electric lift-trucks. The system scope is tailored to the customer's particular needs. ZF supplies pre-finished and fully tested drive and steering systems right to the assembly line – worldwide and also from local production.



GK 26 LD



GP 25

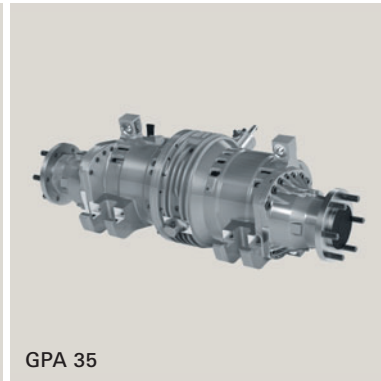

GPA 35



EPS 3



GI 16



GK 20/25

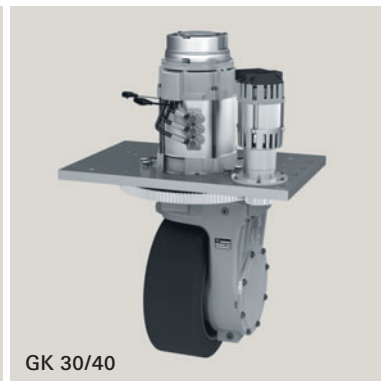

GK 30/40



GK 10



GK 16

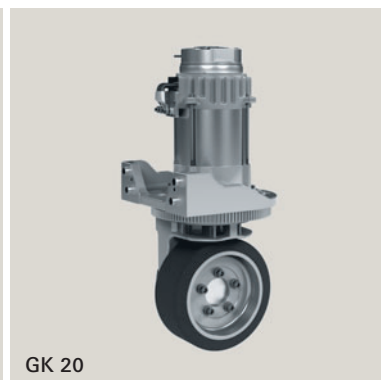

GK 20

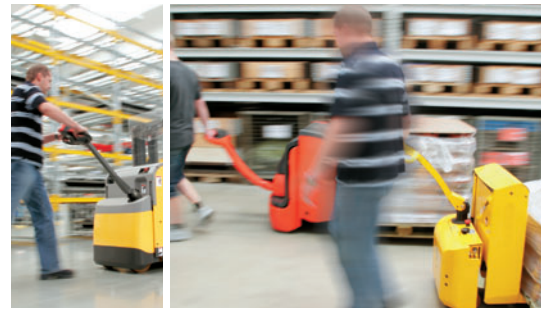

ZF drive systems for electrically driven material handling equipment enable our customers to set benchmarks in terms of energy and handling efficiency. If, for example, you want to get more out of one battery charge, a ZF drive is the right choice. The production quality of gears, optimally set bearings, minimum losses and optimized shaft seals with the smallest possible diameter contribute to this. Independent tests substantiate the quality and benefits of ZF drives.

Advantages of ZF drive systems for electric lift-trucks

- High performance
- High energy and power efficiency
- Low noise emission
- Maintenance-free / extremely service reduced
- Pre-finished, fully tested systems according to customer's requirements
- Reduced expenditure for R&D, logistics, assembly and handling for the vehicle manufacturer
- Consistent service documentations from one source
- Local presence through production sites in Europe, Asia and North America
- Worldwide service network

ZF offers a wide, but specialized range of products.

Regardless of whether counterbalanced lift-trucks, warehouse trucks, elevating working platforms, electric tractors, cleaning vehicles, automatically guided vehicles or special applications are involved, ZF always has a suitable transmission or drive system.

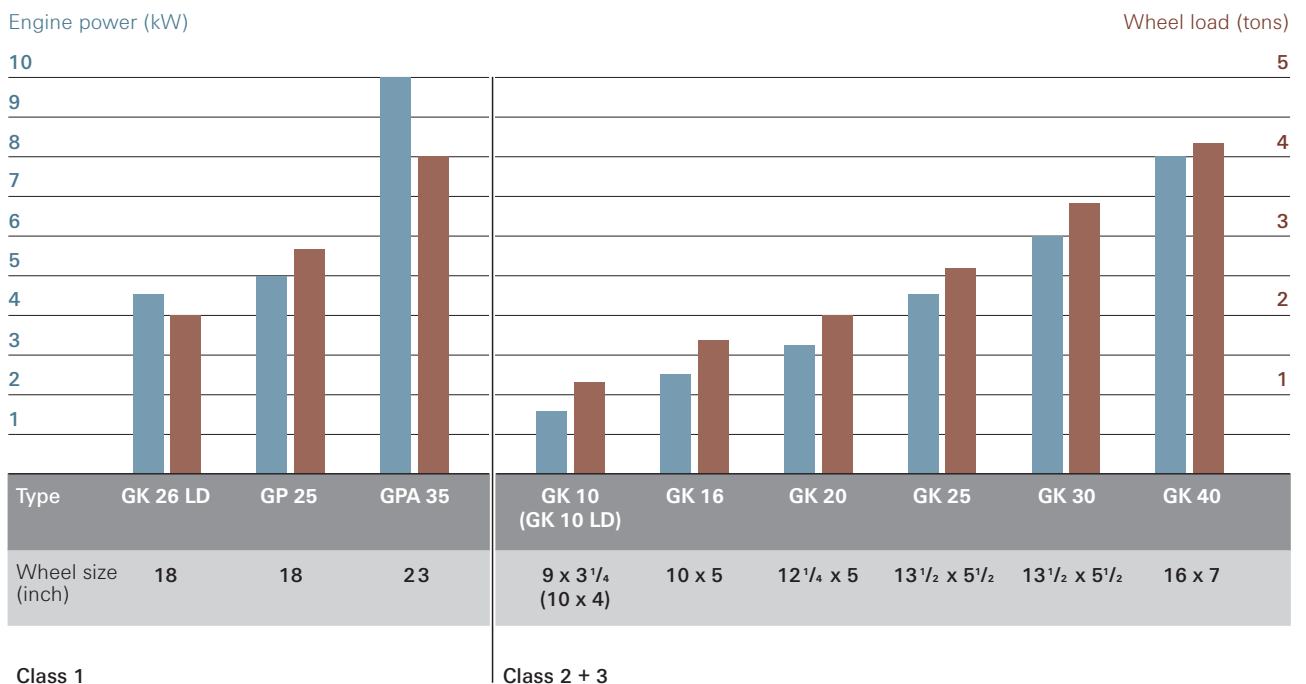

ZF Friedrichshafen AG
Division Industrial Technology
Business Unit Material Handling Systems
94030 Passau
Germany
Phone +49 851 494-4290
Fax +49 851 494-4599
sales.iy@zf.com
www.zf.com

The right is reserved to modify products and technical data.

